

Section Repair & Retread Products

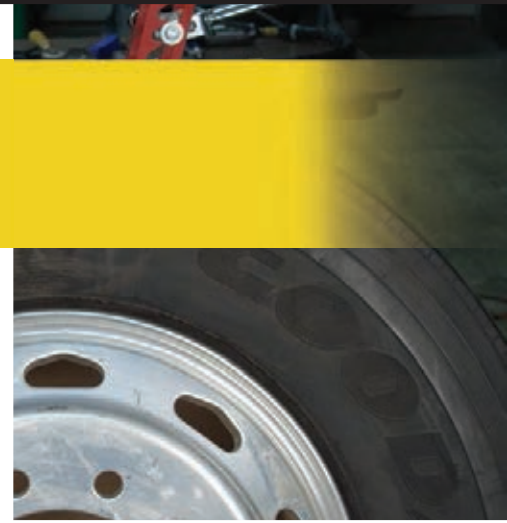
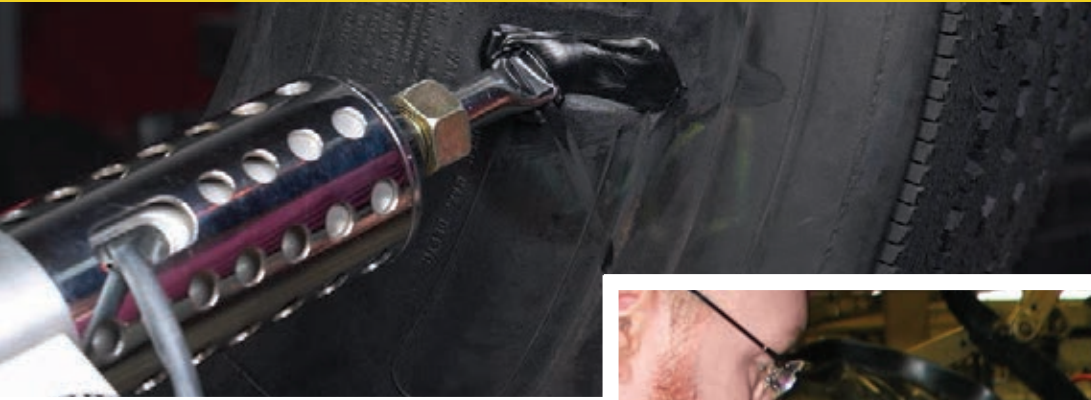

800-998-9897

myerstiresupply.com

We help increase your profits by expanding your capabilities.

It may be as simple as a new set of wheel clamps allowing you to expand wheel services and profits or as technical as the newest alignment system. Depend on your Myers Tire Supply sales representative to keep you current on the newest labor-saving products, helping your business run smoothly and profitably whether it's in the passenger, fleet, OTR or retread market.



Memphis Distribution Center

Myers Tire Supply was founded in 1933 with the philosophy that our success comes from helping our customers be successful. Although markets have changed over 80 years, our philosophy hasn't. Our sales force of professionals offer the broadest range of products, plus training and customer service to help you run your business efficiently and profitably.



◀ *Myers can keep your inventory stocked at the designated levels you need to run your business.*



◀ *The V2B Inflate-Thru valve cap eliminates removing the cap to check tire pressure saving time and money. See pg 32.*

▶ *Myers is your single source for TPMS tools and sensors. We have technical experts on-hand to answer your questions.*



▶ *Myers offers free passenger and truck tire puncture repair classes to assure technicians are following industry-approved standards.*



◀ *Myers has the most complete line of retreading equipment, supplies and tools in the industry.*



◀ *Proper truck wheel torquing is essential for fleet operations. Myers offers an exclusive program to recalibrate and certify torque wrenches. See pg 89.*

▶ *Myers offers a complete line of OTR products including valve hardware, tire changing and tire section repair.*



▶ *Myers branded tools to deliver durable performance at competitive prices.*



Technical Assistance You Can Rely On

Experts are available to help you solve product, application and production problems.

www.myerstiresupply.com

We are continuously adding to and improving our service to you through the web.

Check out our online catalog at:

www.myerstiresupply.com or email us at: sales@myerstiresupply.com

Member of:

SEMA, TIA, TMC, TRIB, RTA



Myers® **Government Services** Tire Supply A Myers Industries Company

The Government Sales office is organized to offer all Myers Industries' products to federal, state, county, municipalities, or local agencies. We offer GSA competitive pricing, and fast bid and quote response via email, fax, or phone on any product. We have been serving our customers since 1933 and our reputation as a reliable supplier is unsurpassed. We are experienced in all facets of export shipping and offer military packaging if necessary.



Myers Tire Supply Federal, State, Local Entities

Email: govsales@myersind.com

Tel: 1-800-644-5592

Fax: 330-761-6187

Myers® **Key Accounts Support** Tire Supply A Myers Industries Company

National and regional accounts know the value of a single-source, national supplier who provides a dedicated Account Manager. Customers choose from the widest selection of tire and undervehicle service supplies and equipment in the country. Celebrating our 80th year in business, our experts are available for problem-solving and education on TPMS, Tire Repair, etc.



Myers® Tire Supply **International, Inc.** A Myers Industries Company

Myers Tire Supply has fully stocked branch/warehouses in Canada and Central America as well as stocking distributors in Europe, Russia, the Far East, and Australia. Our multilingual sales and customer service staff offer international experience in business, shipping, and document preparation as well as an in-depth knowledge of our vast product lines and services.

Myers Tire Supply International, Inc.

Tel: 1-330-253-5592

Fax: 330-761-6226

Guatemala

Tel: 502-24989292

Fax: 502-24989262

El Salvador

Tel: 503-2260-7636

Fax: 503-2260-7176

Panama

Tel: 507-2290926

Fax: 507-2290338

Ontario

Tel: 519-451-3430

Fax: 519-451-6843

Edmonton

Tel: 780-469-3300

Fax: 780-466-2125

Quebec

Tel: 418-948-0770

Fax: 418-948-0771

Table of Contents

Important Information About Our Prices & Terms Of Sale

Prices: Prices are subject to change without notice.

Warranties: All applicable product warranties are provided by each product's manufacturers. Myers makes no warranty, expressed or implied, and expressly disclaims any and all implied warranties including the implied warranty of merchantability and the warranty of fitness for a particular purpose. In no event shall Myers be liable to the buyer for any special, indirect, indirect incidental or consequential damages.

Product: Illustrations and Data: Myers Tire Supply has made every effort to illustrate and describe the products in this catalog accurately; however, these illustrations are for identification only and products may vary due to manufacturing improvements or changes.

Credit: Open account terms of net 15 days are available to customers with approved credit. Mastercard, VISA, and American Express are accepted.

Lease Plans: Equipment in this catalog is available on easy lease plans. Advise us of your needs and complete information will be sent to you immediately. Applicable sales taxes will be payable according to state laws.

Freight: Freight is F.O.B. Origin.

Minimum Billing: A minimum of \$50.00 will be invoiced for any single order totaling less than \$50.00. Please order accordingly.

Sales Tax: Applicable state and local sales tax will be added on every item, and freight if taxable, unless a valid sales tax exemption certificate has been provided for said items at the time the order is placed.

Material Safety Data Sheets: Material safety data sheets are available on request or online at www.myerstiresupply.com

Shipping Errors: You must report any errors in shipping within 48 hours of delivery.

Damaged Shipments: For your own protection, inspect shipments before signing freight bill. If a shipment is damaged, note damage on freight bill and file a claim with the carrier immediately.

Return Policy: To return any item contact Myers Tire Supply to obtain a Return Material Authorization (RMA) before shipping product. We will pay the return shipping cost if the product is visibly defective upon receipt or the return is a result of our error.

If the item is being returned for any other reason, we will accept unused items, with the exception of equipment and special orders, for return within 30 days of the original delivery. Equipment and certain special orders may be subject to a 20% restocking fee. We will credit you in the same manner as your original payment within 10 days of receiving the returned item.

Used items and items that fail to meet the warranty offered by the original manufacturer should generally be returned directly to the manufacturer pursuant to the manufacturer's warranty terms. On occasion, we will facilitate the return of non-conforming goods to a manufacturer through our Return Material Authorization system. In the event we offer to facilitate warranty returns to the original product manufacturer, compensation for the return goods remains subject to inspection of the goods and the manufacturer's original product warranty. Under no circumstances should any such facilitation be construed as the offering of any additional product warranty by Myers Tire Supply Distribution, Inc.

Credit will only be given if shipped back to Myers Tire Supply, Inc.

Ship merchandise returns with the RMA enclosed to:

Myers Tire Supply, Inc., ATTN: Returned Goods, 1293 S. Main St., Akron, OH 44301

Printed in U.S.A.

A Myers Industries, Inc.® Company

Myers Tire Supply is a trademark of Myers Tire Supply Distribution, Inc., a subsidiary of Myers Industries, Inc. The Company is the largest U.S. distributor of tools, supplies, and equipment for tire, wheel, and under-vehicle service. Myers Industries is also an international manufacturer of plastic and rubber products for industrial, agricultural, automotive, commercial, and consumer markets.

Patch Rubber



Pages 1-18

Puncture & Section Repair



Pages 19-48

Retread



Pages 49-82

Parts



Pages 83-90

 **Look for
Made in USA**

Myers
Tire Supply

Table of Contents

A

Adapter Extension.....	79
Akro-Mils ProCart.....	19
Air	
Bags for Earthmover Molds.....	52
Bags for Passenger & Truck Molds.....	52
Compressors, Rotary Screw.....	86
Coupler & Adapters.....	74
Drill.....	31
Stapler.....	65
Tool Conditioner.....	32
Vac.....	53
Air-Rid Cord.....	66
Airless Sprayer for Water Base Cement.....	64
All-Purpose Gum.....	14
Aluminum Embossing Tape.....	74
Angle Grinder.....	33
ARMSTRONG Steam Traps.....	86
ATEC	
Envelope Release Lubricant.....	73
Final Touch Water Base Tire Paint.....	81
Inspection/Painting Station.....	84
Inspection/Repair Station.....	57
NDT Inspector.....	57
Awl, Tire.....	23
AZ Extruder Garter Springs.....	59

B

B&J	
Mulching Rasp Hub.....	60
Buffing Rasp.....	43
Air-Cooled Spacers.....	61, 62
Alu I-Beam Spacers.....	61, 62
Convex Rasp Hub & Refill Blades.....	63
Duro-Max III Rasp Hub & Refill Blades.....	63
Eagle II Rasp Hub & Refill Blades.....	63
Flat Rasp Hub & Refill Blades.....	63
OTR Detreader Buffing Blade.....	60
Outer Support Spacers.....	61, 62
Precure Envelope Tester.....	73
Rasp Hub & Refill Blades for MRT System.....	63
Refill Buffing Blades.....	61, 62
Replacement Pins for Rasp Hubs.....	61, 62
Replacement Spacers.....	61, 62
Rotary Gouger Sharpeners.....	43
Rotary Gougers.....	43
Saturn Rasp Hub & Refill Blades.....	63
Squiggly Rasps.....	43
Threaded Rotary Gougers.....	43

Back Support Belt.....	21
Bail Cutting Knife.....	26
Baird-Style Couplers & Adapters.....	74
Balance Pads.....	8
Ball Bearing Stitcher & Rollers.....	25
Barrel Cradle.....	20
Bead Notcher.....	19
BEA Stapler.....	65
Bead Sealer.....	6
Benches, Work.....	19
Bias Repairs.....	4
Black & Tan Rope Rubber.....	16
BLACK MAGIC Plastic Staples.....	65
Black Repair Cement.....	15
Black String Repairs.....	5
Bladders, Continental.....	79
Boiler Water Treatment.....	86
Boilers, Parker.....	86
Boots, Oval.....	8
Bow Tie Inserts.....	3
BRANICK	
Envelope Sealer Rings.....	67
Tire Cutter.....	19
Tire Spreaders.....	54, 55
Brass	
Bristle Tire Brush.....	25
Hub Stems.....	59
Sidewall Buffing Brushes.....	45
BRITE-MARK	29
Brushes,	
Buffing Hood.....	59
Stipling.....	64
Tire.....	25
Buffer Exhaust Hose.....	58
Buffer Specifications.....	30
Buffing & Finishing Wheels.....	41
Buffing	
Hood Brush Holders.....	58
Hood Brushes.....	58
Stone.....	42
Templates.....	58
Texture Pad.....	60
Bullseye Radial Repair Units.....	4, 7, 9, 10
Butyl Innerliner Gum.....	14
Butyl Innerliner Sealer.....	15
Buzzout Cord.....	66

C

Cabinet Desk.....	19
Cabinet, Flammable Liquids.....	20
Cement Dispensers.....	64
Chamber	
Hose Tester.....	77
Inflation & Exhaust Hoses.....	76
Paint.....	80
Seals.....	75
Check Valve.....	85
Chem-Gum.....	14
Chemical Cure Tube Patches.....	4
Chicago Pneumatic	
High Speed Buffer.....	32
Low Speed Buffer Standard-Duty.....	30
Crayon Holder.....	28
CIMS Date Code Tags.....	74
Circumference-Diameter Tape.....	27
Citra-Clean Pre-Buff Cleaner Fluid.....	6
Clean Out Rope for Extruder Guns.....	16
Cleaner Fluid.....	6, 12
Clock Gauges.....	77
COMPAIR Rotary Screw Air Compressors.....	86
CONTINENTAL Bladders.....	78
Contour Buffing Stone.....	42
Couplers & Adapters, Envelope Seal.....	74
Cooling Systems.....	20
Crayon Holder.....	28
CRS	
Expandable Rim Assemblies.....	59
Tire Buffers.....	57
Curing Chamber Charts.....	75
Curing Rims.....	67
Curved Point Scalpel Knife.....	26
Curved Square Point Knife.....	26
Cushion Gum.....	14
CX Bias Passenger & Truck Repairs.....	7

D

Date Code Tags.....	74
Delugger Blades, Carbide Tipped.....	60
Detreader Cup Cutter.....	60
Digital Pyrometer.....	80
Disposable Dust/Mist Masks.....	60
Disposable Filter Masks.....	60
Do It Right	
Cabinet.....	8
Tire Repair Kit.....	2
Training Classes.....	1

Table of Contents

DOTCO

High Speed Buffer	32
Low Speed Buffer	30, 31
Double End Mill Knife	26
Drum Plug Wrench	20
Drum Truck	20
Dual Cure Tube Patches	4
Dualife Tungsten Carbide Rasps	38
DUO-FAST Stapler & Staples	65
Durometer	80

E

Earplugs	21
Economy	
Tire Paint Sprayer	81
Tire Spreader	54
EcoSeal High Temperature Tire Sealant	18
Electric Knife Heaters	27

ELRICK

Brander	83, 84
Custom Plates	83
Letter & Number Sets	83
Stop Spacers & Blank Spaces	83
EM Bias Repair Units	11
EMR Radial Repair Units	10
EMR-K Giant Tire Radial Repairs	10

Envelope

Coupler & Adapters	74
Lubes	73
Repair Kit	67
Seal Couplers & Adapters	74
Sealer Rings	67
Storage Carts	73
Testers	73, 85
Envelopes, Curing	70, 71, 72

Exhaust

Blower	58
Hose, Buffer	58
Hoses	31

Expandable Hub

Assemblies & Replacement Belts	59
Lubricant	59
Rebuild Kit	59
Replacement Parts	59
Expandable Rim Reconditioning	58
Extruder Guns	17
Extruder Ropes	16
Eyewear, Protective	21

F

Face Shield	21
FASCO Stapler & Staples	65
Fast Trim Vent Knife	27
Fast-Dry Self-Vulcanizing Cement	6
Fiber Bond Cement	15
Filter Masks	60
Filter-Regulator-Lubricators	77
Flammable Liquid Storage Cabinet	20
Flat Faced & Radius Faced	38
Flexible Blade Skiving Knives	26

Flexible Shaft

Adapters	34
Buffers	34
Lubricant	33
Floater Gum	14
Floor Mount Tire Spreader	54

G

Garter Spring for AZ Extruder	59
Giant Tire Extruder Rope	16
Glasses, Protective	21
Gloves	22, 23, 52
Goggles	21
GRACO MONARK Airless Hydra-Sprayer	64
Graphite Lubricating Stick	78
Green Hot Mill Gloves	52
Grinding Stones	35

H

H.V. Chemical Cement	6
HANSON Steam Coupler & Adapter	77
Hawk Bill Knife	26
HAWKINSON NDT	
Probe Assemblies	56
Replacement Chains & Wires	56
Tire Inspectors	56

Hearing Protector	
Heat Insulated Gloves	52
Heat Resistant Rim Flaps	67
Heater Knives	27

High

Heat Chamber Paint	80
Speed Buffers	32, 33
Speed Grinding Stones	35
Temperature Tire Sealant	18
Hub Gauge	58
Hub Stems	59

I

IDEAL

Groover Heads	80
Regroover Blades	80
Tire Regroovers	80
Identification Labels	8
Industrial Shears	25
Inflatable Hub Gauge	58
Infrared Non-Contact Thermometer	80

Ingersoll Rand

Angle Grinder	33
High Speed Buffer	32
Low Speed Buffer	30, 31
Inner Tube Buffing Brush	44
Innerliner Markers	28
Innerliner Scraper	25
Inside Heat Pads, VULCAN-VULCAP	52
Inspection Lights	22
Inspection/Painting Station, Atec	84
Insulated Heater Knives	27

J

J Hooks	85
Jacobs Chucks & Adapters	33
JENSEN	
Disposable Rasps	42
Flat-Faced Carbide Rasps	42
Round-Faced Carbide Rasps	42
Solid Contour Cup Rasps	42
Jet Rasp Sharpener	27
Jet-Vac	53

K

K-Z Regroover	82
Knives	26, 27

L

L.R. OLIVER Rotary Knife	65
Latex Gloves	22
Lights, Inspection	22
LINCOLN Spotters	46, 47, 48
Liquid-Filled Gauge	77
LISTO Marking Pencil	28
Low Speed Buffers	30, 31

M

MARKAL

Fugitive Yellow Marker	28
Paintstik	28
Matrix Vent Drill Bits	78
MICA, Tire Talc	73

Table of Contents

ROBBINS

Accu-Fit II Inside Envelopes	72
CMT Envelopes	70
CMT Outside Envelopes	71
Double Dot Curing Tubes	79
Envelope Lube	73
Envelope Repair Kit	67
Envelopes with Valve	72
Euro-Tubes	78
MRT Outside Envelopes	71
OTR Envelopes	70
PIV Curing Tubes	78
Precure Uni-Tubes	72
Rubber Wick Pad	66
Wick Pad	66

ROOVERS Aluminum Embossing Tape	74
Rotary Gougers	43
Rotary Screw Air Compressors	86
Roughener-Stitcher	25
Round Repair Units	4
Rubber Encapsulated Wire Brushes	40
Rubber Solvent	11, 15

RUBBERHOG

Balls	37
Black Contour Cup	37
Contour Wheel	64
Contour Wheel for Bandag Buffers	37
Disc Wheel	36
Dish Wheel	36
Donut Wheel	64
Donut Wheel for Matteuzzi Buffers	37
Extreme Disc Wheel	36
Extreme Dish Wheel	36
Flared Contour Wheel Polyplugs	37
Flared Contour Wheels	37
Nailhole Reamers	37
Rotor Saw	37
Round Faced Buzzout Wheel	37
Taper	37

S

SARCO Thermodynamic Steam Traps	85
Scraper, Innerliner	25
Sealing Ring Installation Stand	84
Sealing Rings, Envelope	67
Self-Vulcanizing Cement	11
Serial Number Remover/Defacer	27
Sharpening Stone	27
Sharpening Stones for Buffers	60

Shop Desks	19
------------------	----

Sidewall

Buffing Brush	64
Buffing Brush for Bandag Buffers	45
Repair Identification Labels	8
Silver Tire Marking Pen	28
Single End Mill Knives	26
Siphon for Steam Gauge	86
Skidder/Tractor Bias Repairs	13
Skiving Brush & Double Adapter	44
Slic-Tite Pipe Thread Tape	86
Solvent Dispensing Cans	54
Speed Tire Spreader	54
Spray Booths	64
Spray Lube, Stoners	79
Sprayer, Tire Paint	81
Square Point Knives	26
Staple Pulling Tape	66
Staplers & Staples	65

Steam

Ball Valves	85
Coupler & Adapters	77
Reducing Valves	86
Traps	85, 86

Steel Wheel Brush	45
Stem Brushes	45
Stippling Brushes	64
Stitchers & Rollers	25
STONER Spray Lube	79
Stones, High Speed Grinding	35
Storage Cabinet, Flammable Liquids	20
Storage Carts, Envelope	73
String Repairs	5
Stripping Stock	14
STS Bullseye Radial OTR Repair Units	9
Super Sharpener	27
SURE-SHOT Sprayer	73
SURESEAL Envelope Sealer Rings	67

T

T-Handle

Reamer	24
Spiral Probe Cement Tool	24
Tac-A-Disc	43
Tack Rasps & Hubs for Flex Shafts & Drills	43
Tape Measures	27
Taper Point Knife	26

TEMCO

Sanding Drums for Abrasive Sleeves	42
Tungsten Carbide Abrasive Sleeves	42
Texturing Brushes	44
Thermocouple, Multi-Station Digital	80
Thermometer	77
Tilt Table	85
Tire & Rim Brush	25

Tire

Buffers, Hand	30, 31, 32, 33
Buffing Brush	44
Cutter	19
Leak Detector	18
Life & Tire Life Bag	18
Marking Crayons	28
Paint Sprayer	81
Paints	81
Probing Awl	23
Reamers	24
Regroovers	82
Repair Cements	6
Repair Hand Tools	24
Repair Kits	5
Repair Kits, Puncture	2
Tire Seal	18
Tire Seal Liqui-Fill Concentrate	18

Tire

Sidewall Brush	44
Spreaders	54, 55
Stippling Brushes	64
Talc	73
Tire Track	8
Total II Tire & Wheel Protection	18
Traveling Cable Lift Cylinder	84

Tread

Cutting Blades	65
Gum	14
Rope	16
TRIPLEMATIC Extruder Gun	17
Truck Tire Spreader	53
Tube Patches	12
Tubeless Tire Tester	80
Tungsten Carbide Tread Cutting Blades	65
Twisted Wire Brush	44

Table of Contents

U

Uncured OTR Bias Repair Units.....	11
Under Tread Repairs Bias Repairs	11
Universal Patches	4, 12

URYU

Buffer/Skiver	33
OTR Buffer/Skiver Cup Cutter	33

V

V-10 Extruder Cement	15
Vacuums	53
Venting Materials	66
Visitors Spectacles.....	21

VULCAN-VULCAP

Components	52
Inside Air Mandrels	52
Lug Filler Bags	49
Mandrel Packages	51
OTR Tire Repair Clamp.....	51
Section Molds.....	51
Tread Builder/Stitcher.....	65

VULCATEK Tire Repair	11, 12
-----------------------------------	--------

W

Water Base EF-10 Retread Cement	15
White Sidewall Buffing Stone.....	45
Wicking Materials	66
Wide Base Envelope Valves	74

WINNER

Bead Spotter	46
Tire Spotter	49

Wire

Brushes	44
Cord High Speed Grinding Stones.....	35
Cutting Drill Bit	25
Cutting Solid Carbide Cutting Tools	35
Wire Wheel Brushes.....	45, 64
Wonder Air Vacuum	53
Work Benches	19
WYCO Flexible Shaft Buffers.....	34

Y

Y-Strainers.....	85
------------------	----

Patch Rubber

Myers Tire Supply is your tire repair & retread materials headquarters. Founded in 1947, **PATCH RUBBER COMPANY** manufactures the most complete line of tire retreading & repair materials in the industry. From 1/8" Pilot Wire Patch Plugs to 72" EMR giant tire repair units **PATCH RUBBER** has the tire repair products customers need to run their business efficiently & successfully. Through Myers Tire Supply, **PATCH RUBBER** representatives conduct hands-on puncture & section repair training classes. The "Do It Right" classes follow industry-approved procedures & techniques to repair passenger, truck, & OTR tires.



Training materials and seminars are available from Patch Rubber Company.

Puncture Repair

The Do It Right! Program promotes four basic steps for repairing a punctured tire:

Inspect It!



Remove the tire from the wheel for proper inspection of the injury.

Drill It!



Drill the injury to remove any exposed cord.

Fill It!



Fill the injury with a stem or plug unit to seal out moisture and prevent contamination.

Seal It!



Seal the innerliner with a repair unit to prevent air loss.

"Do It Right" Training Classes



Attendees receive a "Certificate Of Participation" when the class is completed.

It is important that the technician performing industry-approved tire repairs for your business be properly trained. Patch Rubber Company's commitment to service involves providing both the specialized training needed to make industry-approved repairs and the materials necessary to reinforce proper repair approved procedures. Patch Rubber Company and Myers Tire Supply provide the training, tools and supplies required to correctly repair tires according to industry established guidelines.

Puncture Repair for Passenger Tires

Detailed instructions for puncture repairs up to 1/4" in radial and bias tires.

Puncture Repair for Truck Tires

Detailed instructions for puncture repairs up to 3/8" in radial and bias truck tires.

Section Repair for Bias & Radial Tires

Instructions for section repairs in bias or radial tires. Manual details repair procedures using a spotter and repairs during the retread cycle.

Section Repair for OTR Tires

A comprehensive OTR tire Section repair manual is available. Sections cover bias & radial tires using dual cure, heat cure, uncured and clothback units.



FREE On-Site Tire Repair Training

- **Puncture & section repair classes available**
- **Repair speed rated tires**
- **FREE classes for passenger, truck & OTR tires**
- **Increase your profit** by repairing punctures following RMA guidelines for permanent tire repairs
- **Hands-on training**, not just videos and lectures!
- **Limit your liability** by learning how to repair punctured tires to manufacturers' specifications
- **Call today** to schedule your free training 1-800-998-9897



myerstiresupply.com

Tire Repair Kits

“Do It Right” Tire Repair Kit

- Everything needed to make industry approved tire repairs to radial passenger & light truck tires



Kit includes (1) each of the following repair materials, Pilot Wire Patch Plugs 1/8", 18 per box (14040); Pilot Wire Patch Plugs 1/4", 18 per box (14041); 1 quart Bead Dressing (16118); 1 pint Repair Sealer (16170); 1/2 pint Fast Dry Cement (16451); 1 quart Cleaner Fluid (16471) and (1) each of the following tools and supplies, Pliers (01061); Akro ALC Container (39085); Blue Akro-Mils Shelf Bin (30130B); Low Speed Buffer/Reamer (31675); 1/2" Reversible Drill (31200M); stitcher (42614); knife (42500); brush (46000); Innerliner Scraper (42620); Adapter For 3/16" Burr (42375); 3/16" Extended Point Burr (42378); Long Pencil Point 1/8" Carbide Cutting Tool (42393); 1/8" Shaft Adapter with Set Screw (42497); Buffing Stone (42642); box of 12 white Paintstik (45121); Probe Awl (47024); Allen wrench (86766); and Safety Glasses (82664)

Order No.	Description	Ship Wt.
47108	Tire Repair Kit for Auto Dealerships	20 lbs. - 9 kg

Puncture Pac Truck Tire Repair Kit

- Put one in your service truck & one in the shop



A compact kit with all the required tools and patch supplies needed to make fast permanent puncture repairs to radial and bias ply passenger and truck tires. Kit includes following repair materials, (30) 2 3/8" All-Rubber Patch (14202); (20) "Bullseye" 10 Radial Patch (12117); (20) "Bullseye" 12 Radial Patch (12118); (20) 2" Reinforced Bias Patch (12021), (24) 3" Reinforced Bias Patch (12142); (1) box (40) 1/4" Plug Stem (14569); (1) box (25) 3/8" Plug Stem (14570); 1 Qt. Bead Dressing (16118); 1 Pt. Repair Sealer (16170); 1/2 Pt. Fast-Dry Cement (16451); 1 Qt. Cleaner Fluid (16471); (6) Pull-Thru Wires (14526), and (1) each of the following tools and supplies, Adapter for 3/16" Burr (42375); 3/16" Extended Point Burr (42378); 3/16" Extended Point Burr (42379); Adapter for 3/16" Burr (42376); Buffing Stone (42642); Adapter for Buffing Stone (42420); box of 12 white Paintstik (45121); Pliers (01061); brush (46000); Low Speed Buffer/Reamer (31675); Flexible Blade Knife (42500); Stitcher (42614); Innerliner Scraper (42620); Probe Awl (47024); Safety Glasses (82599); Allen wrench (86766); and Heavy-Duty Tool Box (45588); 1/2" Reversible Drill (31200M)

Order No.	Description	Ship Wt.
47107	Truck Tire Repair Kit	21 lbs. - 10 kg

Puncture Pac Passenger Tire Repair Kit



A compact kit with all the required tools and patch supplies needed to make fast permanent puncture repairs to radial passenger and light truck tires. Kit includes the following repair materials, 2 boxes (20) "Bullseye" 10 Radial Patch (12117); (1) box (50) UP2 Universal Patch 2 1/8" x 2 1/8" (14209); (1) box (40) 1/4" Plug Stem (14569); (6) Pull-Thru Wires (14526); 1 Qt. Bead Dressing (16118); 1 Pt. Repair Sealer (16170); 1/2 Pt. Fast-Dry Cement (16451); 1 Qt. Cleaner Fluid (16471), and (1) each of the following tools and supplies, 3/16" Extended Point Burr (42378); Adapter for 3/16" Burr (42375); Buffing Stone (42642); Adapter for Buffing Stone (42420); box of 12 white tire Crayons (45121); Pliers (01061); Low Speed Buffer/Reamer (31675); Flexible Blade Knife (42500); Stitcher (42614); Innerliner Scraper (42620); Brass Bristle Brush (46000); Probe Awl (47024); Safety Glasses (82599); Allen wrench (86766); and Heavy-Duty Tool Box (45588); 1/2" Reversible Drill (31200M)

Order No.	Description	Ship Wt.
47106	Passenger Tire Repair Kit	18 lbs. - 8 kg

Patch “Do It Right” Cabinet



(Tools and supplies sold separately)



Organize and store all the tools and supplies required to perform professional repairs in passenger or truck tires. Heavy-duty, 24-gauge steel cabinet to hang on a wall or set on workbench. Magnetic locking double doors open to 60" wide. Includes built-in tool rack and small parts tray. 24" h. x 30" w. x 12" d. Supplies sold separately.

Order No.	Description
14219	Dispenser Cabinet

Tire Repair Tip:

- Always stitch tire repair units from the center outward to avoid trapping air. Trapping air under the repair unit may cause repair failure.

Plug Stems

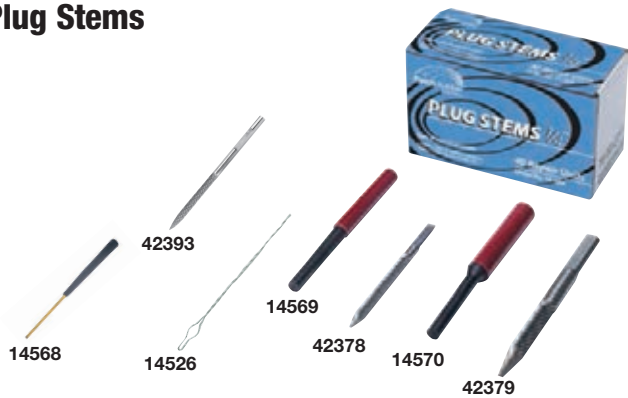

Use to fill injuries in conjunction with carbide cutters and/or plug cutters. Rubber cured plug covered with Dual Cure Cushion Gum for filling injuries. Apply with Fast-Dry Cement see page 6.

Order No.	Size Inches	mm	Qty. Box	Carbide Cutters*
14568	1/8	3	50	42393
14569	1/4	6	40	42378
14570	3/8	10	25	42379
14571	1/2	15	25	42373
14572	5/8	15	20	42164
14574	1	25	15	42367
14576	1 1/4	30	10	N/A
14526	Pulling Wire		1	

Bow Tie Inserts

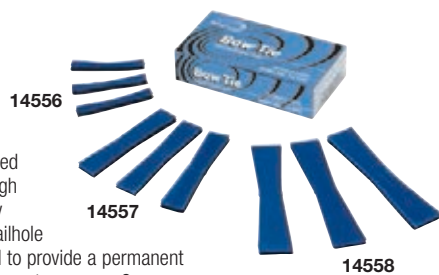

These inserts are manufactured with a specially formulated high tensile rubber and covered by Dual Cure Cushion Gum. A nailhole repair unit should be installed to provide a permanent repair. Apply with Fast-Dry Cement see page 6.

Order No.	Description	Size Inches	mm	Qty. Box
14556	Passenger Bow Tie	3/8 x 2 3/8	10 x 60	50
14557	Truck Bow Tie	5/8 x 3 1/8	15 x 80	20
14558	EW Bow Tie	3/4 x 4	20 x 100	20

Repair Inserts

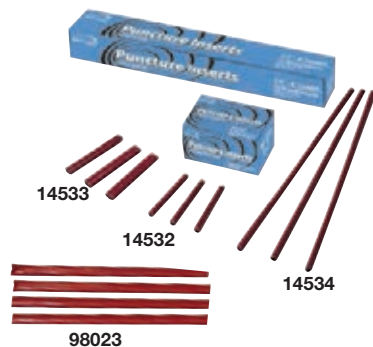

All inserts are composed of a core of cured rubber covered with Dual Cure Cushion Gum. The large diameter OTR EM Oval Inserts help eliminate "ganging" smaller inserts to repair punctures in OTR tires. A combination of compression and chemical vulcanization locks inserts into the injury. Apply with Fast-Dry Cement see page 6.

Order No.	Description	Mfr. No.	Size Inches	mm	Qty Box
14532	Round Insert	R 2	3/4 x 2	6 x 50	20
14534	Round Insert	R 8	3/4 x 8	6 x 200	15
14533	Oval Insert	O 2	3/8 x 2	10 x 50	20
14535	Oval Insert	O 9	3/8 x 9	10 x 230	15
98023	OTR Insert	EM	1/2 x 8	15 x 200	10

Note: Plug Stems are for use in the crown area on passenger, light truck, and truck tires. They should always be used as part of a two-piece repair with a repair unit to seal the innerliner.

Pilot Wire Patch Plugs

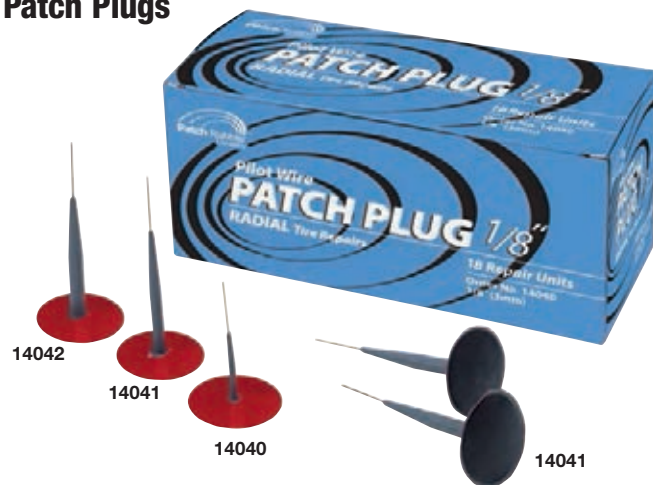

The combination patch plugs fills and seals the injury in one step. Use the 1/8" units to seal pinhole leaks, keeping the injury as small as possible. The 1/8" unit is also acceptable for the repair of Z-rated tires in the tread only. 1/4" units are the maximum puncture repair limit for passenger and light truck tires. Choose any of the Patch Plug repairs for truck tire punctures up to 3/8".

The wire tip, molded into the repair units, eliminates pull-thru wires and makes them easy to thread through the injury from inside the tire. The stem and repair unit are coated with Dual Cure Cushion Gum creating a permanent bond to the tire with increased adhesion compared to chemical cure repair units. Apply with Fast-Dry Cement see page 6.

The proper carbide cutter reams and standardizes the injury for the installation of the Pilot Wire Patch Plug (see chart).

Order No.	Size Inches	mm	Patch Dia. Inches	mm	Qty. Box	Carbide Cutters*
14040	1/8	3	1 3/4	45	18	42393
14041	1/4	6	1 3/4	45	18	42378
14042	3/8	10	1 3/4	45	18	42379

Quilled Patch Plugs



Use for crown puncture repairs in bias and radial passenger and truck tires. The metal quill facilitates insertion and protects the plug from damage in steel belted tires.

Order No.	Mfr. Code	Stem Dia. Inches	mm	Patch Dia. Inches	mm	Qty. Box	Carbide Cutters
14508	QPP 2	1/4	6	2 1/4	55	25	42378
14509	QPP 3	5/16	8	2 1/4	55	25	42395
14510	QPP 4	3/8	10	1	100	10	42379
14511	QPP 5	1/2	15	4	100	10	42373

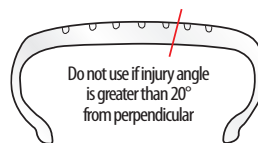

Note: Pilot Wire Patch Plugs are for use in the crown area on passenger, light truck, and truck tires if the angle of penetration is not more than 20° from the perpendicular. If the angle is greater than 20° use a separate plug stem and the appropriate repair unit.

Patch Rubber Tire Puncture Repair

Chemical Cure Tube Patches



Chemical Cure Repair Units are molded to a feather edge and feature a chemical curing base gum with the ultimate in green tack, along with extended poly backing for ease of removal and installation. Apply with Fast-Dry Cement see page 6.

Dispenser Box

Patch Pack

Order No.	Mfr. Code	Inches	Size mm	Qty. Box	Order No.	Mfr. Code	Qty. Pkg.
Round							
12000	PR 0	1 1/8	30	100	12040	PP 0	200
12001	PR 1	1 3/8	35	30	12041	PP 1	150
12002	PR 2	2	50	30	12042	PP 2	100
12003	PR 3	2 1/4	55	30	12043	PP 3	100
12016	PR 4	3	75	30	12044	PP 4	50
12018	PR 5	3 3/8	90	10	-	-	-
12019	PR 6	4 1/2	115	10	-	-	-
Oval							
12005	PR 7	1 3/8 x 3	35 x 75	30	-	-	-
12006	PR 7A	2 x 4 1/4	50 x 110	30	-	-	-
12008	PR 7C	3 1/2 x 6	90 x 150	10	-	-	-
12010	PR 7D	4 1/2 x 8	115 x 200	10	-	-	-
12012	PR 7E	5 1/2 x 10	140 x 255	10	-	-	-

Dual Cure Tube Patches



Dual Cure Repair Units feature a base gum that cures chemically or with heat. This soft, high-tack gum is less prone to problems associated with moisture, handling and cement drying time. Apply with Fast-Dry Cement see page 6.

Order No.	Mfr. Code	Description	Inches	Size mm	Qty. Box
14201	SR	Small Round	1 1/8	40	40
14202	MR	Medium Round	2 3/16	55	30
14203	LR	Large Round	3	75	20
14204	SO	Small, Oval	1 3/8 x 2 1/4	35 x 55	30
14205	MO	Medium Oval	2 x 4	50 x 100	20
14225	PP SR	Small Round Patch Pack	1 1/8	40	150
14226	PP MR	Medium Round Patch Pack	2 3/16	55	125
14227	PP LR	Large Round Patch Pack	3	75	50

Round Repair Units



Non-directional round repair unit for puncture repairs in radial tires. Use with appropriate plug filler material, see page 3. Apply with Fast-Dry Cement see page 6.

Order No.	Mfr. Code	Inches	Size mm	Qty. Box
97935	RSR	1 3/4	45	30
97936	RMR	2 1/4	55	25
97937	RLR	3 3/8	80	15

Bullseye Repair Units



Bullseye Repair Units provide maximum reinforcement and adhesion making them the preferred patch for the "Do It Right!" industry-approved repair method. Use with appropriate plug filler material, see page 3. Apply with Fast-Dry Cement see page 6.

Order No.	Mfr. Code	Inches	Size mm	Qty. Box
12117	BUL DC 10	2 1/8 x 2 13/16	55 x 70	20
12118	BUL DC 12	2 3/16 x 4 1/4	65 x 110	10
12090	BUL DC 20	2 1/16 x 4 3/16	70 x 115	10
12091	BUL DC 22	2 7/8 x 5 1/2	75 x 140	10

Bias Repairs



Used for puncture repairs in bias ply passenger, light truck, and truck tires. Each unit features a large, reinforced platform providing added strength while maintaining maximum flexibility. Use with appropriate plug filler material, see page 3. Apply with Fast-Dry Cement see page 6.

Order No.	Mfr. Code	Inches	Size mm	Qty. Box
12021	CX 1	1 13/16	45	20
12022	CX 2	2 3/8	60	20
12023	CX 3	3 1/4	85	10
12024	CX 4	4 3/8	120	10

Universal Patch



Universally used for puncture injuries in every type of tire: passenger, light truck, truck, bias, radial, tubeless or tube-type. Special compound formulation makes a simplified repair for everything from pinholes to 3/8" punctures. Use with appropriate plug filler material, see page 3. Apply with Fast-Dry Cement see page 6.

Order No.	Mfr. Code	Inches	Size mm	Qty. Box	Order No.	Mfr. Code	Qty. Pkg.
14208	UP 1	1 1/8 x 1 1/8	50 x 50	100	-	-	-
14209	UP 2	2 1/8 x 2 1/8	55 x 55	50	14211	TB UP 2	200
14210	UP 3	2 3/8 x 2 3/8	65 x 65	50	14212	TB UP 3	150

Radial Repairs



Specifically constructed for puncture repairs in radial tires. SM RAD and MD RAD feature a large, reinforced platform providing added strength while maintaining maximum flexibility. Use with appropriate plug filler material, see page 3. Apply with Fast-Dry Cement see page 6.

Order No.	Mfr. Code	Size Inches	Size mm	Qty. Box	Order No.	Mfr. Code	Qty. Pkg.
12211	SM RAD	1 3/4 x 3 1/4	45 x 80	20	12213	PP SM RAD	75
12212	MD RAD	2 1/4 x 4 1/4	50 x 110	10	12214	PP MD RAD	50

Plug Gun & Plugs



Features a manual Plug Gun which easily inserts an all rubber mushroom headed plug securely into the injury. Standard nozzle (15026) will accommodate both 5/16" and 3/8" diameter plugs. The (15027) nozzle is required for 7/16" plugs. Gun includes 5/16" and 3/8" nozzle.

Plug Gun		Plug	
Order No.	Description	Order No.	Size (inches)
15025	Manual Plug Gun	15033	5/16
15026	5/16 Repl. Nozzle	15032	3/8
15027	7/16 Repl. Nozzles	15034	7/16

Heavy-Duty String Repairs



Constructed of twisted cord permeated with butyl rubber. The high tensile cord assures no breakage during insertion while the soft and tacky butyl rubber seals the injury. Passenger and truck kits are available, complete with all required tools for repairing bias and radial tires.

Order No.	Description
15057	Passenger Repair Kit
Refill No. 15058	50 Passenger H.D. Strings
15066	T-Handle with Needle Split Eye
15067	Pass. Needle Split Eye
15065	T-Handle with Spiral Cement Tool
15060	Truck Repair Kit
Refill No. 15061	25 Truck H.D. Strings
15069	T-Handle with Needle Split Eye
15070	Truck Needle Split Eye
15065	T-Handle with Spiral Cement Tool

Mono-Fil Inserts

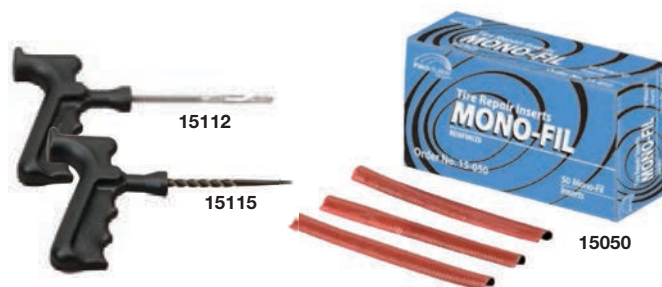

Mono-Fil Inserts utilize a nylon reinforced material with a Dual Cure Cushion Gum allowing the unit to be inserted without cutting or tearing and ensures a Dual Cure Vulcanization to create a solid bond with the tire. When used with an appropriate repair unit, a permanent repair is achieved. Apply with Fast-Dry Self-Vulcanizing Cement see page 6.

Order No.	Description	Size Inches	Size mm	Qty. Box
15049	Mini Mono-Fil	7/32	6	50
15050	Pass. Mono-Fil	1/4	6	50
15112	Split Eye Insert Tool	-	-	1
15115	Spiral Cement Tool	-	-	1

Black String Repairs



Black rubber coated strings are designed for puncture repairs in bias ply tires.

Order No.	Description	Qty. Box
15158	Black String	50
15111	Closed Eye Insert Tool	1

Repair Kits



Tools, cement and materials to perform emergency repairs on bicycle, auto, truck, and tractor tires. Also suitable for repairs to inner tubes, rubber sporting goods, rain gear, and other rubber goods.

Order No.	Description
15274	Bicycle Kit, 5 Repair Units, Cement & Scraper
15275	Motorists Kit, 4 Repair Units, Cement & Scraper
15276	Truck Kit, 22 Repair Units, Cement & Scraper
15277	Tractor Kit, 33 Repair Units, Cement & Scraper

WARNING: The repair materials on this page are for emergency temporary repairs only. The damaged tire should be taken to a repair facility and removed from the rim for inspection and a proper repair.

Patch Rubber Tire Repair Cements

Fast-Dry Self-Vulcanizing Cement



Developed to reduce drying time. Fast-Dry Self-Vulcanizing Cement eliminates the most common cause of failed repairs – lack of proper drying time. Flammable. Flash point -4°F. Shelf life 1 year.

Order No.	Size	Per Case	Ship Wt.
16451	½ Pt	12	7 lbs. - 3 kg
16450	1 Qt	6	11 lbs. - 5 kg
16452	1 Gal	4	32 lbs. - 14 kg

H.V. Chemical Cement

- Blue color aids application

Specially formulated for applications where a tackier cemented surface is required. Fast drying solvent reduces waiting time and repair failures due to wet cement. Use with Dual Cure or Heat Cure repair units. Blue color enables the repairman to see where cement has been applied. Contains no carcinogenic chlorinated solvents. Flammable. Flash point -4°F. Shelf life 1 year.



Order No.	Size	Per Case	Ship Wt.
16460	8 Oz	12	6 lbs. - 3 kg

Cleaner Fluid



Dissolves lubricants and contaminants prior to buffing. Also used to help remove excessive buffing dust prior to applying repair units. Its cleaning action maximizes adhesion. Available in an aerosol (non-flammable mixture) or spout type (flammable mixture – Flash point -4°F) can.

Order No.	Size	Per Case	Ship Wt.
Aerosol (Flammable)			
16483	10 Oz.	12	11 lbs. - 5 kg
Liquid (Flammable)			
16471	1 Qt.	6	12 lbs. - 5 kg
16472	1 Gal.	4	32 lbs. - 14 kg

Bead Sealer



Bead Sealer is a thick, high-solid content, black sealant. Brush on the beads of tubeless tires during mounting. Forms an air tight seal between the tire and rim reducing bead leaks. Quick, economical and profitable way to end comebacks from bead leaks. Flammable. Flash point 14°F. Shelf life 1 year.

Order No.	Description	Size	Per Case	Ship Wt.
16118	Bead Sealer	1 Qt.	6	12 lbs. - 5 kg
16119	Bead Sealer	1 Gal.	4	32 lbs. - 14 kg

Repair Sealer

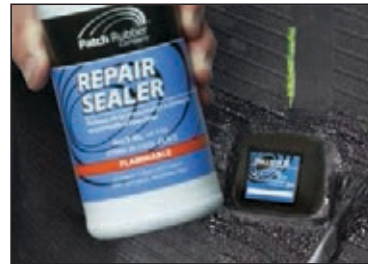

Used to restore the air impermeability of an overbuffed or damaged innerliner. Can be used in a service application or prior to the repair/retreading cycle. Flammable material. Flash point 14°F. Shelf life 1 year.

Order No.	Description	Size	Per Case	Ship Wt.
16170	Repair Sealer	1 Pt.	12	6 lbs. - 3 kg
16171	Repair Sealer	1 Gal.	4	32 lbs. - 15 kg

Citra-Clean Pre-Buff Cleaner Fluid

- Environmentally-friendly
- Use to clean innerliner prior to buffing

Made from orange peels to dissolve lubricants and contaminants prior to buffing. Its cleaning action maximizes adhesion. Spout type (flammable mixture – Flash point -4°F) quart can.



Order No.	Size	Per Case	Ship Wt.
16485	1 Qt	6	12 lbs. - 5 kg

Bullseye Radial Repair Units



Used to repair puncture and section injuries in passenger, light truck, heavy-duty truck and farm tractor radial tires. Bullseye Repair Units can be centered over the injury because of special cord reinforcement and ply construction. This special construction reduces the effects of flexing and reduces inventory requirements since they can be used for crown, shoulder and sidewall repairs. Specify Dual Cure or Heat Cure Units to maximize the tire repair performance of the repair system. Apply Dual Cure Units with Fast-Dry Cement (see page 6.) and Heat Cure Units with appropriate cement required for the repair system.



Bullseye Radial Passenger & Truck Repairs

Dual Cure

Heat Cure



Order No.	Mfr. Code	Order No.	Mfr. Code	Size		Qty. Box
				Inches	mm	
12117	BUL DC 10	12217	BUL HC 10	2 1/8 x 2 13/16	55 x 70	20
12118	BUL DC 12	12218	BUL HC 12	2 9/16 x 4 1/4	65 x 110	10
12119	BUL DC 14	12219	BUL HC 14	3 x 5 1/4	75 x 135	10
12090	BUL DC 20	12290	BUL HC 20	2 13/16 x 4 9/16	70 x 115	10
12091	BUL DC 22	12291	BUL HC 22	2 7/8 x 5 1/2	75 x 140	10
12092	BUL DC 24	12292	BUL HC 24	2 7/8 x 7 3/8	75 x 195	10
12089	BUL DC 26	12289	BUL HC 26	3 1/2 x 10	90 x 255	10
12093	BUL DC 40	12293	BUL HC 40	4 1/8 x 8 1/8	105 x 205	10
12094	BUL DC 42	12294	BUL HC 42	5 1/4 x 10 1/4	135 x 260	10
12095	BUL DC 44	12295	BUL HC 44	5 7/8 x 13	130 x 330	10

Bullseye Radial Tractor Repairs

Dual Cure



Order No.	Mfr. Code	Size		Qty. Box
		Inches	mm.	
12060	BUL DC 80	5 3/4 x 8	145 x 205	5
12061	BUL DC 82	7 3/8 x 9 7/8	190 x 250	5
12062	BUL DC 84	8 1/4 x 11 1/2	210 x 290	5
12063	BUL DC 86	9 3/4 x 13 3/4	250 x 350	5

Bullseye Reinforced Shoulder Repairs



NOTE: For repair of punctures up to 3/8" in commercial, tractor, grader and haul tires. Both ends of the repair unit must be anchored in non-flex zones.

Dual Cure

Order No.	Mfr. Code	Size		Qty. Box
		Inches	mm	
12118	BUL DC 12	2 9/16 x 4 1/4	65 x 110	10
12119	BUL DC 14	3 x 5 1/4	75 x 135	10
12090	BUL DC 20	2 13/16 x 4 9/16	70 x 115	10
12092	BUL DC 24	2 7/8 x 7 3/8	75 x 195	10
12101	BUL DC 37	5 x 7 1/2	125 x 190	10
12093	BUL DC 40	4 1/8 x 8 1/8	105 x 205	10
12095	BUL DC 44	5 1/8 x 13	130 x 330	10

Bullseye Radial Crown Truck Repairs

Dual Cure

Heat Cure



Order No.	Mfr. Code	Order No.	Mfr. Code	Size		Qty. Box
				Inches	mm	
12096	BUL DC 33	12296	BUL HC 33	4 x 5 1/8	100 x 130	
12097	BUL DC 35	12297	BUL HC 35	5 x 6 3/4	125 x 160	10
12101	BUL DC 37	12301	BUL HC 37	5 x 7 1/2	125 x 190	10

CX Bias Passenger & Truck Repairs

Used for puncture, reinforced and section repairs in passenger, light truck, heavy-duty truck and tractor bias ply, tube-type or tubeless tires. Made with full-ply construction, die cut and molded to a compact octagonal shape for strength and ease of installation. Specify Dual Cure or Heat Cure Units to maximize the tire repair performance. Apply Dual Cure Units with Fast-Dry Cement (see page 6.) and Heat Cure Units with appropriate cement required for the repair system.

Dual Cure

Heat Cure



Order No.	Mfr. Code	Order No.	Mfr. Code	Size			Qty. Box
				Inches	mm	Ply	
12142	CX DC 3-2	12542	CX HC 3-2	3	75	2	24
12143	CX DC 4-2	12543	CX HC 4-2	3 13/16	95	2	12
12145	CX DC 6-2	12545	CX HC 6-2	6	150	2	12
12146	CX DC 5-3	12546	CX HC 5-3	5	125	3	12
12147	CX DC 7-3	12547	CX HC 7-3	7 1/4	185	3	12
12148	CX DC 6-4	12548	CX HC 6-4	6	150	4	12
12150	CX DC 8-4	12550	CX HC 8-4	8 3/4	210	4	12
12151	CX DC 10-4			10	255	4	12
12153	CX DC 13-4			13	330	4	6
12154	CX DC 16-4			16	405	4	6
12155	CX DC 9-6			9	230	6	12
12156	CX DC 12-6			12	305	6	6
12157	CX DC 15-6			15	380	6	6
12158	CX DC 16-8			16	405	8	6
12159	CX DC 18-8			18	460	8	6



Patch Rubber Specialty Materials

RFID Units

- Inside or outside of tire applications

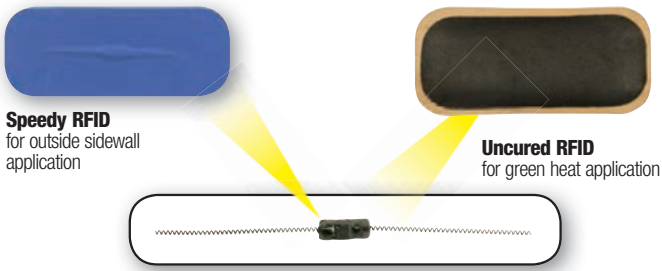

Record serial, manufacturer, and product numbers all in the same RFID. Ideal for commercial fleets, OEs, Government and aircraft. RFID reduces or eliminates the numerous labels applied to tires. Readers may be tethered to a PC, tethered to a PDA or PDA integrated. Speedy Tag for outside of tire application and cured unit for green/heat application. Many choices of readers and suppliers exist.

Order No.	Mfr. Code	Description	Qty. Box
98273	Gen 2	Gen 2 NXP Cured RFID	10
98267	Gen 2	Gen 2 NXP Speedy RFID	10

Identification Labels



Dual-curing, high-profile identification labels apply easily and permanently to any tire and most rubber products. Available in a variety of colors, shapes and sizes with custom imprints.

Order No.	Description	Qty. Box
12242	1 3/4 Color Label - Specify Color	500
98000	Custom ID Decal	

Sidewall Repair Identification Labels



Blue triangle indicates a reinforced sidewall section repair has been made to the tire.

Order No.	Description	Qty. Box
12231	Blue Triangle	100

"Do It Right" Cabinet



(Tools and supplies sold separately)

Organize and store all the tools and supplies required to perform professional repairs in passenger or truck tires. Heavy-duty, 24-gauge steel cabinet to hang on a wall or set on workbench. Magnetic locking double doors open to 60" wide. Includes built-in tool rack and small parts tray. 24" h. x 30" w. x 12" d. Supplies sold separately.

Order No.	Description
14219	Dispenser Cabinet

Tire Track

- Permanently bonds to new or used tire casings
- Barcode is cut deeply into the rubber for permanent identification.
- Will not wear off



Tire-Track is a sequential, permanent rubber bar code label designed for tire identification, tire management, tire tracking or tire inventory programs. The unit replaces tire branding and provides a barcode and eye readable number. It can also include an industry approved RFID sensor for tires. Applies to the outside sidewall using only chemical cement. The unit is a two-piece design featuring a Primer Gum.

Order No.	Description	Qty. Box
98979	CLV ID	250
98977	Primer Gum	500

Balance Pads



Install in the crown area for proper tire balance in passenger, truck and aircraft tires. A dual-curing, high-gravity balance pad available in precise, controlled weights of 1/2 to 10 ounces.

Order No.	Weight oz.	Weight gr	Qty. Box
14601	1/2	14	25
14600	3/4	21	25
14602	1	28	25
14603	1 1/2	43	25
14604	2	57	25
14605	2 1/2	71	25
14606	3	85	25

Order No.	Weight oz.	Weight gr	Qty. Box
14607	3 1/2	99	25
14608	4	113	25
14609	4 1/2	128	25
14610	5	142	25
14611	6	170	25
14613	8	227	25
14615	10	283	25

Oval Boots



Oval Boot feature a shape for quick and easy installation. Oval Boots are designed for temporary emergency repairs in truck and farm tires. Units made from cord-impregnated rubber provide a smooth, non-chaffing top surface. Apply with Black Repair Cement, see page 15.

Order No.	Mfr Code	Description	Inches	Size mm	Qty. Box
15251	1T	Oval Boot	4 x 5	100 x 125	50
15252	2T	Oval Boot	5 1/2 x 8	140 x 200	50
15253	3T	Oval Boot	7 x 10	180 x 255	50
15254	4T	Oval Boot	9 x 12	230 x 305	25
15255	5T	Oval Boot	10 x 14	255 x 355	25
15256	6T	Oval Boot	12 x 15	305 x 380	10

HEAT SHIELD

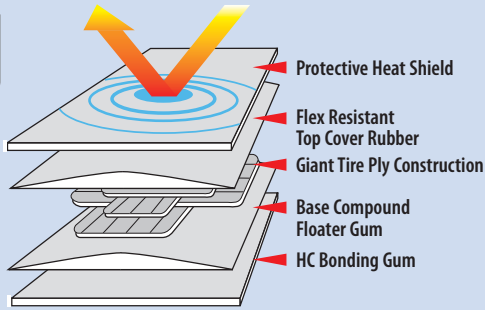

All Heat Cure Giant Tire Repair Units are covered with a special heat-resistant layer and marked by a Heat Shield Protected decal. This Heat Shield protects the entire repair unit from oxidation and heat degradation caused by the extreme operating temperatures common in giant tires.

Bullseye Radial OTR Repair Units

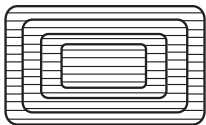

For section repairs in radial-ply off-the-road tires. These Bullseye Units feature an elongated stepdown between plies, together with additional top cover stock allowing the repair units to be centered over the injury and anchored in any flex area of the tire.

Bullseye Radial Repairs

Dual Cure		Heat Cure		Size	Qty. Box
Order No.	Mfr. Code	Order No.	Mfr. Code		
12070	BUL DC 46	12270	BUL HC 46	6 1/8 x 17 1/4	5
12071	BUL DC 50	12271	BUL HC 50	8 1/2 x 23	5
12072	BUL DC 52	12272	BUL HC 52	10 1/2 x 23 1/2	5
12073	BUL DC 56	12273	BUL HC 56	11 1/2 x 29 1/2	2
12074	BUL DC 60	12274	BUL HC 60	11 1/2 x 39 1/2	2

Bullseye Radial Crown Repairs

Clothback		Heat Cure		Size	Qty. Box
Order No.	Mfr. Code	Order No.	Mfr. Code		
12069	BUL DC 45	12269	BUL HC 45	9 x 7 1/2	5
12075	BUL DC 55	12275	BUL HC 55	13 x 10	5
12076	BUL DC 65	12276	BUL HC 65	16 x 12	3
12077	BUL DC 75	12277	BUL HC 75	21 x 17	3

What are Aramid fibers?

A synthetic material that is stronger than its weight in steel. Due to its light weight, superior strength, and temperature resistance, Aramid fibers are used in products subjected to extreme environmental conditions. When infused with rubber in a tire repair unit, Aramid fibers create a lightweight, flexible extremely durable repair unit.

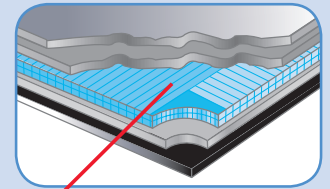

Reinforced with Aramid Fibers

STS Bullseye Radial OTR Repair Units

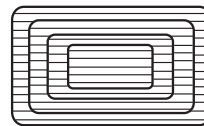

Advanced technology combines high strength with light weight to create a stronger, more flexible repair unit making them easier to install. The reinforcing Aramid fibers are stronger and lighter than nylon or steel reinforced units. The stronger STS units reduce the "bulge effect" in radial sidewall section repairs. Clothback products provide extended shelf-life and must be installed with 18-150 floater gum see pg. 14.

Bullseye Radial Repair Units

Clothback		Heat Cure		Size	Qty. Box
Order No.	Mfr. Code	Order No.	Mfr. Code		
13946	BUL CB 46 STS	13846	BUL HC 46 STS	5 x 16	5
13950	BUL CB 50 STS	13850	BUL HC 50 STS	7 x 21	5
13952	BUL CB 52 STS	13852	BUL HC 52 STS	9 x 21	5
13956	BUL CB 56 STS	13856	BUL HC 56 STS	9 x 28	2
13960	BUL CB 60 STS	13860	BUL HC 60 STS	10 x 38	2

Bullseye Radial Crown Repairs

Clothback		Heat Cure		Size	Qty. Box
Order No.	Mfr. Code	Order No.	Mfr. Code		
13945	BUL CB 45 STS	13845	BUL HC 45 STS	9 x 7 1/2	5
13955	BUL CB 55 STS	13855	BUL HC 55 STS	13 x 10	5
13965	BUL CB 65 STS	13865	BUL HC 65 STS	17 x 13 1/2	3
13975	BUL CB 75 STS	13875	BUL HC 75 STS	21 x 17	3
13985	BUL CB 85 STS	13885	BUL HC 85 STS	29 x 22 1/2	1

Patch Rubber OTR Repair Units

EMR Radial Repair Units

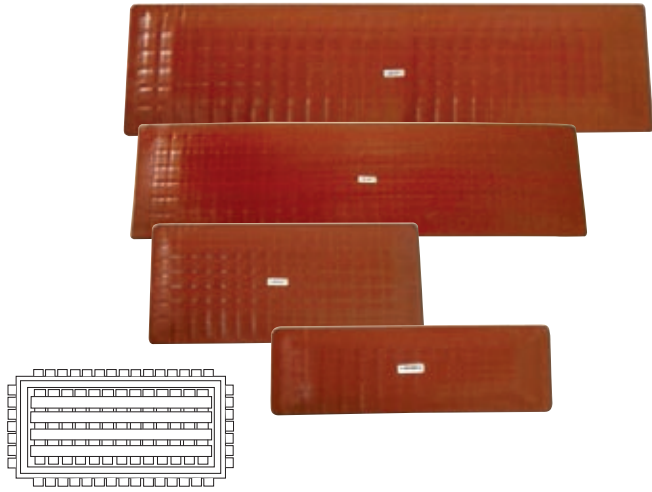

For section repairs in radial ply off-the-road tires. A combination of EM and radial tire construction techniques have created a specially-reinforced radial, off-the-road tire repair, which is extremely flexible and is equally suited for larger sidewall and shoulder injuries. Apply with Black Repair Cement see page 15.

Uncured

Order No.	Mfr. Code	Size		Qty. Box
		Inches	mm	
10295	EMR 15	5 x 16	125 x 405	5
10296	EMR 20	9 x 20	230 x 510	5
10297	EMR 27	10 x 27	255 x 685	5
10298	EMR 38	10 x 38	255 x 965	5

For non-flex to non-flex application.

Wide-Base EMR Repair Units

A larger version of the EMR Radial Repair units. These Wide-Base EMR repair units have more surface area for increased adhesion. A strong repair for severe repair service on haulage tire or other off-road tires. Apply with Black Repair Cement see page 15.

Uncured

Order No.	Mfr. Code	Size		Qty. Box
		Inches	mm	
10300	EMR 40 WB	17 1/2 x 40	445 x 1015	3
10301	EMR 20 WB	11 x 20	280 x 510	5
10302	EMR 27WB	13 1/2 x 27	345 x 685	5
10303	EMR 15 WB	7 x 15 1/2	180 x 395	5

For non-flex to non-flex application.

Bullseye Radial Tractor Repairs



For tread and sidewall section repairs in radial off-the-road tires. Bullseye Radial Tractor Repairs are constructed of one-directional fabric for reinforcement of the radial ply package. Special rubber compound gives maximum adhesion and resists over cures and the effects of radial tire flexing. Apply with Fast-Dry Cement see page 15.

Dual Cure

Order No.	Mfr. Code	Size		Qty. Box
		Inches	mm	
12060	BUL DC 80	5 3/4 x 8	145 x 205	5
12061	BUL DC 82	7 3/8 x 9 7/8	185 x 250	5
12062	BUL DC 84	8 1/4 x 11 1/2	210 x 290	5
12063	BUL DC 86	9 3/4 x 13 3/4	250 x 350	5

EMR-K Giant Tire Radial Repairs



Embedded Aramid cord platform limits or eliminates sidewall bulge

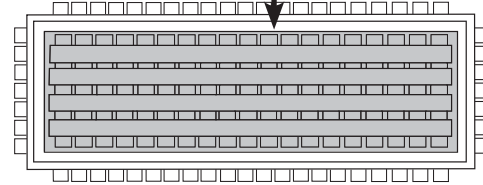

Radial haulage tires are the most abused tires in use today. The giant tires are subject to long hauls at high speeds in over-loaded conditions causing heat build-up and injuries.

The lengths of these new EMR-K Radial Repair units ensure both ends are "anchored" in Non-flex areas at the bead and the crown. The units are reinforced with Aramid fiber to limit or eliminate sidewall bulges that sometimes occur. The units may be cured in autoclaves and section molds. Heat pads for fixed and flexible Monarch Vulcanizing and Vulcan Vulcap systems are available.

Uncured

Order No.	Mfr. Code	Size		Qty. Box
		Inches	mm	
For 51" Radial Tires				
10250	EMR-K51	51 x 10	1295 x 255	3
10260	EMR-K 51WB	51 x 17 1/2	1295 x 445	5
For 57" Radial Tires				
10251	EMR-K 57	57 x 10	1450 x 255	5
10261	EMR-57KWB	57 x 17 1/2	1450 x 445	5
For 63" Radial Tires				
10252	EMR-K 63	63 x 10	1600 x 255	5
10262	EMR-K 63WB	63 x 17 1/2	1600 x 445	5

"Do It Right" Training Classes



do it right!



It is important that the technician performing industry-approved tire repairs for your business be properly trained. Patch Rubber Company's commitment to service involves providing both the specialized training needed to make industry-approved repairs and the materials necessary to reinforce proper repair approved procedures. Patch Rubber Company and Myers Tire Supply provide the training, tools and supplies required to correctly repair tires according to industry established guidelines.

EM Bias Repair Units

For reinforcement and section repairs in bias ply off-the-road tires. The EM Repair Units have plies made from strips of cord overlaid in an intricately-spaced design to form a "square lattice". This design allows the repair unit to flex with the tire.

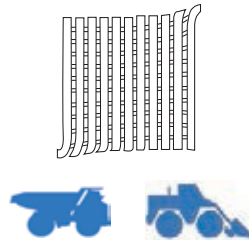

Uncured		Dual Cure		Heat Cure		Size		Qty. Box
Order No.	Mfr. Code	Order No.	Mfr. Code	Order No.	Mfr. Code	Inches	mm	
10304	EM 4	12304	EM DC 4	12404	EM HC 4	8 3/4	220	15
10306	EM 6	12306	EM DC 6	12406	EM HC 6	10 3/4	260	10
10308	EM 8	12308	EM DC 8	12408	EM HC 8	12 7/8	325	8
10310	EM 10	12310	EM DC 10	12410	EM HC 10	14 7/8	380	6
10312	EM 12	12312	EM DC 12	12412	EM HC 12	17 1/4	440	5
10314	EM 14	12314	EM DC 14	12414	EM HC 14	18 3/4	475	5
10316	EM 16	12316	EM DC 16	12416	EM HC 16	21	535	2
10318	EM 18	12318	EM DC 18	12418	EM HC 18	23 1/4	590	1
10320	EM DC 20	12320	EM DC 20	12420	EM HC 20	27 1/4	690	1

Uncured OTR Bias Repair Units

For reinforcement and section repairs in bias ply off-the-road tires, the OTR Repair Units have solid-ply construction, providing a large platform repair area in a smaller patch. Die-cut edges distribute the cord-end stresses across a radiused area, preventing lifting of the cord edges.

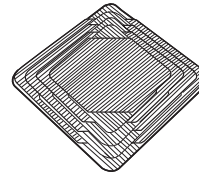

Order No.	Mfr. Code	Size		Qty. Box
		Inches	mm	
10340	OTR 4	6	150	10
10342	OTR 6	8	205	10
10344	OTR 8	10	255	10
10346	OTR 10	12	305	5
10348	OTR 12	14	355	5
10350	OTR 14	16	405	5
10352	OTR 16	18	460	2
10354	OTR 18	20	510	1
10356	OTR 20	24	610	1

Under Tread Repairs Bias Repairs



Compact repair units for reinforced and section repairs in truck and off-the-road tires. Constructed of specially-cut and fabricated plies, these units can be counter-sunk into the buffed casing in the crown area and cured during the retread process. Use in conjunction with bias ply repair units to make a sandwich repair.

Uncured

Order No.	Mfr. Code	Size		Qty. Box
		Inches	mm	
10105	UT 6-4	6 x 4	150 x 100	25
10108	UT 8-4	8 x 4	200 x 100	20
10110	UT 10-6	10 x 6	255 x 150	10
10111	UT 12-8	12 x 8	305 x 205	5
10112	UT 14-10	14 x 10	355 x 255	5

Apply with Black Repair Cement, see pg 262

Self-Vulcanizing Cement

- Activates vulcanization to bond patch to the tire casing

Self-Vulcanizing cement dries quickly to speed repair process. Flammable, flash point -4° F. 1-year shelf life.



Order No.	Description	Size	Per Case	Ship Wt.
94391	Self-Vulcanizing Cement	8 oz.	12	1 lbs. -1 kg

Rubber Solvent

- Dissolves lubricants & contaminants

Removes excess buffing dust. Provides clean surface for maximum adhesion. Flammable, flash point 0° F.



Order No.	Description	Size	Per Case	Ship Wt.
94392	Rubber Solvent	1 Qt.	6	2 lbs. -1 kg

Vulcetek Patches & Plugs

Tube Patches

- For any size tube repair



Chemically cures at room temperature. Use with Vulcetek Self-Vulcanizing Cement.

Order No.	Description	Size		Qty. Box
		Inch	mm	
Round Tube Patches				
94300	CVT 0	1 1/4	30	50
94301	CVT 1	1 3/8	35	50
94302	CVT 2	1 3/4	45	25
94303	CVT 3	2 1/4	55	25
94304	CVT 4	2 7/8	75	25
94305	CVT 5	3 3/16	80	10
Oval Tube Patches				
94306	CVT 02	1 1/16 x 1 1/2	25 x 30	50
94307	CVT 07	2 7/8 x 1 3/8	75 x 35	25
94308	CVT 08	4 1/2 x 1 3/4	105 x 45	25

Universal Patches

- For puncture repairs in every type of tire – bias or radial, tubeless or tube-type



Chemically cures at room temperature or with heat and pressure. Use with Vulcetek Self-Vulcanizing Cement and plug filler material.

Order No.	Description	Size		Qty. Box
		Inch	mm	
94211	CVUP 1	2	51	40
94212	CVUP 2	2 3/8	60	30
94213	CVUP 3	3 3/8	82	25

Bias Patches

- For repairs to bias ply passenger, light truck and truck tires



Full ply construction with a compact shape for strength and easy installation. Chemically cures at room temperature or with heat and pressure. Use with Vulcetek Self-Vulcanizing Cement and plug filler material.

Order No.	Description	Size		Qty. Box
		Inch	mm	
94221	CVB 32	3 9/16	90	25
94222	CVB 42	4 9/16	115	25
94223	CVB 52	5 3/4	145	10
94224	CVB 64	6	150	10
94225	CVB 106	10	255	5
94226	CVB 126	12	305	5

Repair Sealer

- Repairs damaged or overbuffed innerliner & seals repairs



Flammable, flash point 14° F. 1-year shelf life

Order No.	Description	Size	Per Case	Ship Wt.
94393	Repair Sealer	1 Pt.	12	1 lbs. - 1 kg

Radial Patches

- For repairs to radial ply passenger, light truck & truck tires



Suitable for crown, shoulder and sidewall repairs. Special cord and ply construction allows repair units to be centered over the injury. Chemically cures at room

temperature or with heat and pressure. Use with Vulcetek Self-Vulcanizing Cement.

Order No.	Description	Size		Qty. Box
		Inch	mm	
94231	CVR 10	2 1/8 x 2 13/16	55 x 70	10
94232	CVR 12	2 3/8 x 4 3/8	60 x 105	10
94233	CVR 14	2 7/8 x 5	75 x 125	10
94234	CVR 20	2 7/8 x 4 7/8	75 x 105	10
94235	CVR 22	2 7/8 x 6	75 x 150	10
94236	CVR 24	2 7/8 x 8 1/8	75 x 205	10
94237	CVR 40	4 x 7 3/8	100 x 195	5
94238	CVR 42	5 x 10	125 x 255	5
94239	CVR 44	5 x 13	125 x 330	5

Pilot Wire Patch Plugs

- Use for puncture repairs in radial passenger & truck tires
- Combination patch & plug fills & seals in one step



Order No.	Size		Patch Dia.		Qty. Box
	Inches	mm	Inch	mm	
94340	1/8"	3	1 9/16	40	18
94341	1/4"	6	1 7/8	50	18
94342	3/8"	10	1 7/8	50	18

Pilot Wire Plug Stems

- Use for puncture repairs in radial passenger & truck tires
- Rubber cured plug covered with Dual Cure Cushion Gum



Order No.	Description	Size		Qty. Box
		Inch	mm	
94251	1/8" Plug Stem	1/8	3	5
94253	1/4" Plug Stem	1/4	6	5
94255	3/8" Plug Stem	3/8	10	5

Bead Sealer

- Brush on beads of tubeless tires during mounting to form an airtight seal between tire & rim



Flammable, flash point 14° F. 1-year shelf life.

Order No.	Description	Size	Per Case	Ship Wt.
94394	Bead Sealer	1 Qt.	6	2 lbs. - 1 kg

Skidder/Tractor Bias Repairs



These repair units feature a large ply platform to accommodate the large injuries commonly found in skidder and tractor section repairs, yet are lightweight and flexible in light ply tires. The multi-directional repair units may be applied parallel or perpendicular to the beads to properly repair any type of injury.

Dual Cure

Order No.	Mfr. Code	Size		Ply	Qty. Box
		Inches	mm		
12431	SKD DC 1	9 x 12	230 x 305	4	5
12432	SKD DC 2	11 x 15	280 x 380	4	5
12433	SKD DC 3	12 x 17	305 x 430	4	5
12434	SKD DC 4	13 x 19	330 x 485	4	5
12435	SKD-DC 5	9 x 12	230 x 305	6	5
12436	SKD DC 6	11 x 15	280 x 380	6	5
12437	SKD DC 7	12 x 17	305 x 430	6	5
12438	SKD DC 8	13 x 19	330 x 485	6	5
12451	HDSKD DC 6	11 x 15	280 x 380	8	5
12452	HDSKD DC 7	11 x 15	280 x 380	10	5
12453	HDSKD DC 8	12 x 17	305 x 430	10	5
12454	HDSKD DC 9	13 x 19	330 x 485	10	5

OTR Repair Inserts & Tools

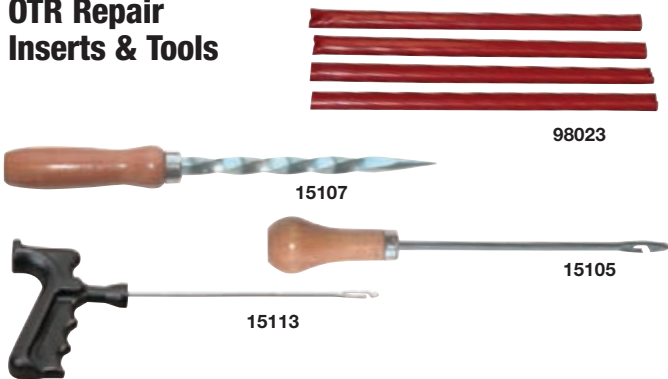

These new large diameter EM Oval Inserts help eliminate "ganging" smaller inserts to repair punctures in OTR tires. The inserts are composed of a core of cured rubber covered with Dual Cure Cushion Gum.

Dual Cure

Order No.	Mfr. No.	Description	Size		Qty. Box
			Inches	mm	
98023	EM	OTR Insert	½ x 8	15 x 205	10
15113		Open Eye OTR Insert Tool			
15105		OTR Insert Tool			
15107		OTR Spiral Cement Tool			

Quick Cure Tube Gum

RMA Cure Class 15A/20C

Reduce the time it takes to repair tubes, rubber products and vulcanize tube-replacement valves. Quick cure rate: 15 min/280° F, 20 min/260° F. Shelf life: 1 year. Use with Brush-Type Cement, see page 15.

Order No.	Width x Gauge	Ship Wt.
15151	9 x ⅜ 230 x 1.5	5 lbs. - 2 kg

Precure Cushion Gum

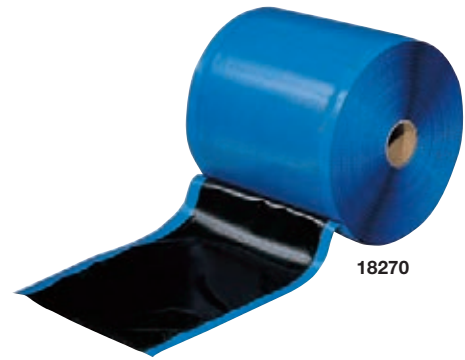

RMA Cure Class 10A/15C

Use as an undertread bonding gum to vulcanize the precure tread to the casing. May be used as splicing gum and repair material for buzz-outs and exposed cords. Excellent heat and overcure resistant properties. Features uniform gauge tolerances and superior building tack. Stable curing compound for distortion-free tread appearance. Yield approximately 14 tires per box. Cure rate: 8 min/280° F, 15 min/260° F. Shelf life: 3 months. Use with Spray-Type Retread and Vulcanizing Cement, see page 15.

Order No.	Inches	Size	mm	Ship Wt.
18270	5 ¾ x .060		145 x 1.5	35 lbs. - 16 kg
18272	6 ¼ x .060		160 x 1.5	35 lbs. - 16 kg
18274	6 ¾ x .060		170 x 1.5	35 lbs. - 16 kg
18271	7 x .060		180 x 1.5	35 lbs. - 16 kg
18273	7 ⅝ x .060		195 x 1.5	35 lbs. - 16 kg
18275	8 ¼ x .060		210 x 1.5	35 lbs. - 16 kg
18277	8 ⅝ x .060		220 x 1.5	35 lbs. - 16 kg
18278	9 ¼ x .060		235 x 1.5	35 lbs. - 16 kg

Precure Cushion Strip



Cure rate: 8 min/280° F, 15 min/260° F. Shelf life: 3 months.

Order No.	Inches	Size	mm	Ship Wt.
18265	2 ½ x ¾		55 x 10	160 lbs. - 73 kg

Patch Fast Gum

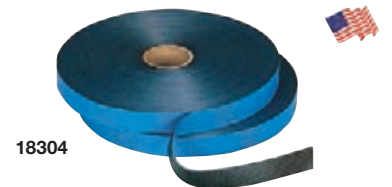

RMA Cure Class 10A/15C

Use for general purpose repairing to reduce cure time. Developed for fast curing at a wide range of temperatures. Has excellent resistance to overcure. Suitable for all types of repairs. Cure rate: 8 min/280° F, 15 min/260° F. Shelf life: 3 months.

Order No.	Inches	Size	mm	Ship Wt.
18304	1 x ⅜		25 x 1.5	30 lbs. - 14 kg



Patch Rubber Repair Gums

Cushion Gum

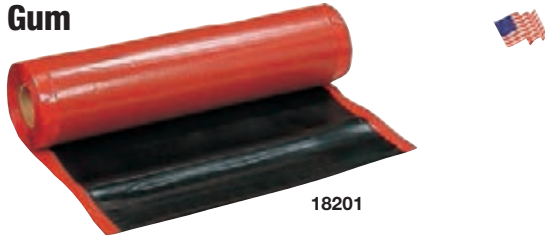

18201

RMA Cure Class 20A/35C

Fill buzz-outs over exposed cords, spot repairs, reinforce repairs and section repairs. Natural rubber compound with excellent tack and workability. Cure rate: 20 min/280° F, 35 min/260° F. Shelf life: 1 year. Use with Brush-Type Cement, see page 15.

Order No.	Size		Ship Wt.
	Inches	mm	
18202	18 x 1/64	460 x .4	10 lbs. - 5 kg
18198	2 x 1/32	50 x .8	30 lbs. - 14 kg
18199	3 x 1/32	75 x .8	30 lbs. - 14 kg
18191	4 x 1/32	100 x .8	25 lbs. - 12 kg
18193	6 x 1/32	150 x .8	25 lbs. - 12 kg
18201	18 x 1/32	460 x .8	10 lbs. - 5 kg
18196	4 x 1/16	100 x 1.5	25 lbs. - 12 kg
18197	6 x 1/16	150 x 1.5	25 lbs. - 12 kg
18200	18 x 1/16	460 x 1.5	10 lbs. - 5 kg

Tread Gum



18207

RMA Cure Class 20A/35C

Use to make repairs exposed to wear and/or weather conditions. Tough, abrasion-resistant compound with excellent finishing and wearing qualities. Cure rate: 20 min/280° F, 35 min/260° F. Shelf life: 1 year. Use with Brush-Type Cement, see page 15.

Order No.	Size		Ship Wt.
	Inches	mm	
18207	18 x 1/16	460 x 1.5	10 lbs. - 5 kg

All-Purpose Gum



15044

RMA Cure Class 20A/35C

Multi-purpose repair gum combines the properties of cushion and tread gums. Soft and pliable to enhance workability in all types of repairs. Cure rate: 20 min/280° F, 35 min/260° F. Shelf life: 1 year. Use with Brush-Type Cement, see page 15.

Order No.	Size		Ship Wt.
	Inches	mm	
15044	18 x 1/8	460 x .3	10 lbs. - 5 kg
15045	18 x 1/16	460 x 1.5	10 lbs. - 5 kg
15046	7 x 1/4	180 x 6	25 lbs. - 12 kg

Stripping Stock



18222

RMA Cure Class 20A/35C

Free-flowing stock for stripping edges of tread rubber to cover overbuff and improve sidewall appearance. Cure rate: 20 min/280° F, 35 min/260° F. Shelf life: 1 year. Use with Brush-Type Cement, see page 15.

Order No.	Size		Ship Wt.
	Inches	mm	
18222	1 x 1/16	25 x 1.5	25 lbs. - 12 kg
18223	2 x 1/16	50 x 1.5	25 lbs. - 12 kg
18225	3 x 1/16	75 x 1.5	25 lbs. - 12 kg

Butyl Innerliner Gum



RMA Cure Class 20A/35C

Use in conjunction with an uncured repair unit as a cover stock to protect the finished repair from heat degradation and cracking caused by the extreme operating temperatures common in giant tires. Butyl Innerliner Gum assures air impermeability of the repair and can also be used to repair the damaged innerliner. Cure Rate: 20 min/280° F, 40 min/260° F. Shelf life: 6 months. Use with Brush-Type Cement, see page 15.

Order No.	Width x Gauge		Ship Wt.
	Inches	mm	
18156	18 x 1/16	460 x 1.5	10 lbs. - 5 kg

Floater Gum



All-natural gum specially compounded to use with EM patches. High flex-resistant quality floater gum acts as a shock absorber between the tire and EM patch. Shelf life: 1 year. Use with Black Brush Type Cement. Cure Rate: 20 min/280° F, 40 min/260° F. Shelf life: 6 months. Use with Brush-Type Cement, see page 15.

Order No.	Width x Gauge		Ship Wt.
	Inches	mm	
18150	18 x 1/8	460 x 3	10 lbs. - 5 kg

Chem-Gum



Chemical Cure

Use for field service repairs such as tread and shoulder snags, cuts in sidewalls and bead repairs. Compounded to cure chemically. Shelf life: 6 months. Apply with Fast Dry Self-Vulcanizing Cement to both sides of gum for proper vulcanization see page 6.

Order No.	Width x Gauge		Ship Wt.
	Inches	mm	
18317	9 x .045	230 x 1.1	10 lbs. - 5 kg

Repair Cords



15007

Use to build reinforced repairs to tires, conveyor belting and other types of fabric-reinforced rubber goods. High tensile-strength tire cord calendered with high-quality skim compound to a uniform gauge. Cure rate: 30 min/280°F, 50 min/260°F. Shelf life: 1 year. Use with Brush-Type Cement, see page 15.

Order No.	Description	Width x Gauge		Ship Wt.
		Inches	mm	
15007	Nylon	29 x 3/64	735 x 1.2	19 lbs. - 9 kg
15009	Polyester	29 x 3/64	735 x 1.2	19 lbs. - 9 kg
98006	Nylon Sq. Woven	28 x 3/64	710 x 1.2	15 lbs. - 7 kg
98001	Nylon H.D. Sq. Woven	28 x 1/16	710 x 1.5	15 lbs. - 7 kg
98007	Aramid Cord	28 x .045	710 x 1.1	15 lbs. - 7 kg
98008	Aramid Cord	56 x .045	1420 x 1.1	15 lbs. - 7 kg

Black Repair Cement



16327

Use for buzz-outs, exposed fabric and with uncured gums. A fast-drying, penetrating, heat-curing cement. Use with repairs that are vulcanized with heat and pressure. (Section, reinforced and spot repairs.) Flammable. Flash point below 0° F. Shelf life: 1 year.

Order No.	Size	liter	Ship Wt.	Per Case
16325	1 Qt	1.0	12 5	6
16326	1 Gal	3.8	32 15	4
16327	5 Gal	18.9	39 18	1

V-10 Extruder Cement



16346

This widely-used retread cement is formulated for maximum green tack on hot extruded strip or die-sized rubber applications. Humidity and/or temperature does not affect green tack properties. Flammable. Flash point below 0° F. Shelf life: 1 year.

Order No.	Size	liter	Ship Wt.
16346	5 Gal	18.9	35 lbs. - 16 kg
16348	54 Gal	205	385 lbs. - 173 kg

Fiber Bond Cement



16350

A high solid content cement for hot and cold tread rubber application. Available in spray or brush type for retreading and repairing. Excellent adhesion and tack in all humidity conditions. Flammable. Flash point below 0° F. Shelf life: 1 year.

Order No.	Size	liter	Ship Wt.
16354	5 Gal. Spray Type	18.9	35 lbs. - 16 kg
16355	54 Gal. Spray Type	205	385 lbs. - 173 kg
16349	1 Gal Brush Type	3.8	8 lbs. - 4 kg
16350	5 Gal Brush Type	18.9	35 lbs. - 16 kg
16351	54 Gal Brush Type	205	418 lbs. - 188 kg

Rubber Solvent



16221

A high grade solvent used for thinning solvent based products. Flammable. Flash point below 0° F.

Order No.	Size	liter	Ship Wt.
16220	1 Gal	3.8	6 lbs. - 3 kg
16221	5 Gal	18.9	35 lbs. - 16 kg
16222	54 Gal	205	385 lbs. - 173 kg

Butyl Innerliner Sealer



16290



16291

This two part mixture, when brushed onto damaged innerliners, will cure at room temperature and renew the air retention properties of the innerliner. Heavy, viscous butyl cement to be mixed with activator. Once ingredients are mixed, sealer is usable for up to 3 hours. Flammable. Flash point below 0°F. Shelf life: 1 year.

Order No.	Item	Size	liter	Ship Wt.
16290	Sealer	1 Gal	3.8	9 lbs. - 4 kg
16239	Activator	50cc Tube	—	1 lbs. - 5 kg
16291	Sealer	5 Gal	18.9	40 lbs. - 18 kg
16240	Activator	250cc Can	—	2 lbs. - 1 kg

Water Base EF-10 Retread Cement



Performs like conventional retreading cements, contains no hazardous materials, and is Non-flammable. Color changes from light gray to flat black as cement dries, indicating when it is ready to continue the retread process. Compatible with all mold cure and precure retreading systems. Apply with high volume/low pressure spray equipment. Yields over 300 tires per pal.

Order No.	Item	Size	liter	Ship Wt.
16360	WB EF-10 Spray Type	5 Gal	18.9	43 lbs. - 20 kg
16370	WB Cleaning Solution	5 Gal	18.9	43 lbs. - 20 kg

Patch Rubber Extruder Ropes

Extruder Rope

- RMA Cure Class 10A/15C
- Recommended for final tread applications only



All Purpose Extruder Rope. A soft extrudable compound that eliminates air pockets, flows easily into contours and crevices of buzz-outs. Made with Fast Cure material. Consistent quality reduces gun maintenance problems. Cure rate 8 minutes at 280°F, 15 minutes at 260°F. Shelf life 3 months. Use with Black Brush Type Cement, see page 15. *See below for export shipment. (Sold per lb.)

Order No.	Description	Width		Ship Wt.
		Inches	mm	
18122	Extruder Rope	3/8"	10	25 lbs. - 11 kg

Tread Rope

- RMA Cure Class 20A/35C
- Recommended for final tread applications only



Formulated to provide a finished repair with tread rubber qualities yet is still easily processed through the extruder gun. Cure rate 20 minutes at 280°F, 35 minutes at 260°F. Shelf life 1 year. Use with Black Brush Type Cement, see page 15.

Order No.	Description	Width		Ship Wt.
		Inches	mm	
18118	Tread Rope	3/8"	10	25 lbs. - 11 kg

Giant Tire Extruder Rope

- RMA Cure Class 12A/18C



A custom formulated extruder rope for OTR tire repairs. Giant Tire Extruder Rope bridges the gap between standard extruder rope and tread rope. One rope for both uses. Cure rate: 8 min/280°F, 15 min/260°F. Shelf life 6 months. Use with Black Brush Type Cement, see page 15.

Order No.	Description	Width		Ship Wt.
		Inches	mm	
18116	Giant Tire Extruder Rope	3/8"	10	30 lbs. - 14 kg

Clean Out Rope for Extruder Guns

CAUTION: Clean extruder guns thoroughly if unused for 20 minutes. Operation with cured rubber in the barrel may cause the extruder to bind resulting in severe damage.



Extruder clean out rope will not cure. It is used at the end of the shift to flush out all the regular extruder rope in the barrel. The next morning, after the extruder gun is heated to operating temperature, the operator feeds regular extruder rope and flushes through the gun until all the white material is ejected through the tip. A 5 lb. carton includes ten 10 ft. rolls of white extruder rope.

Order No.	Description	Ship Wt.
14994	Extruder Gun Clean Out Rope	6 lbs. - 3 kg

Black & Tan Rope Rubber

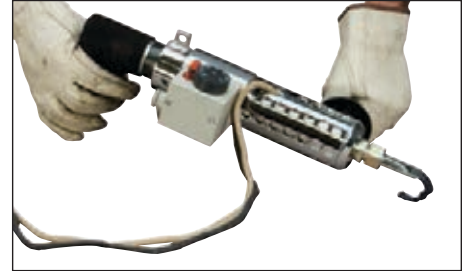

Feed Black and Tan Extruder Rope through an extruder gun to form a repair putty. Once it is properly mixed, the repair putty compound chemically cures at room temperature. Use with Black Brush Type Cement, see page 15. **Caution:** Use Extruder Clean Out Rope (14994) to push out the mixed Black and Tan compound.

Order No.	Description	Width		Ship Wt.
		Inches	mm	
18120	Tan Extruder Rope	1/4	6	10 lbs. - 5 kg
18121	Black Extruder Rope	1/4	6	10 lbs. - 5 kg



FREE On-Site Tire Repair Training

- **Puncture & section repair classes available**
- **Repair speed rated tires**
- **FREE classes for passenger, truck & OTR tires**
- **Increase your profit** by repairing punctures following RMA guidelines for permanent tire repairs
- **Hands-on training**, not just videos and lectures!
- **Limit your liability** by learning how to repair punctured tires to manufacturers' specifications
- **Call today** to schedule your free training 1-800-998-9897

*ATTENTION: International Customers - FRT EXPORT

Most repair materials listed are either Fast Cure 10A/15C (3 month shelf life) or Regular Cure 20A/35C (1 year shelf life). Due to shelf life consideration for export shipments, The Patch Rubber Company provides our Fast Cure material in a special international cure rate (FRT 15A/20C). This FRT cure material will provide extended shelf life over Fast Cure material and still enable the end user to have reduced cure cycles when compared to regular cure materials. Minimum order 500 Lbs.

CAUTION: Clean unit thoroughly if unused for 20 minutes. Operation with cured rubber in the barrel may cause the repair extruder to bind and cause severe damage!

Mini Extruder Gun with Bosch Motor

- Cuts material waste
- Repair parts page 87



A lightweight extruder ideal for truck and OTR tire repairs. Fills injuries in a fraction of the time needed to hand stitch cushion gum into the injury. Adjustable thermostat 32° to 248°. Requires 90 to 100 psi. Available 110v or 220v.

Order No.	Description	Ship Wt.
15002	Mini Extruder 110V	9 lbs. - 4 kg
15022	Mini Extruder 220V	9 lbs. - 4 kg

Myers Repair Service Available on ALL Makes of Extruders

Extruder Gun

- Fill buzz-outs 5 times faster than hand stitching
- Cuts material wastes & eliminates trapped air
- I-R air motor
- High output 40 lbs./hr
- Repair parts page 86



Optional Tool Balancer 15004
6-1/2 to 13-1/2 lbs

Works like a caulking gun to fill skived areas with hot flowing repair rubber. Ideal for truck and OTR tire repairs. Eliminates hand stitching. The electrically heated gun barrel is controlled with a thermostat adjustable from 32°-248°F. The lightweight extruder is air-operated and requires 90-100 psi. Always use a patch to seal the innerliner. Available 110 or 220V.

Order No.	Description	Ship Wt.
14975	Extruder Gun 110V	9 lbs. - 4 kg
14976	Extruder Gun 220V	9 lbs. - 4 kg
15004	Optional Tool Balancer - 6.5 to 13.5 lbs.	4 lbs. - 2 kg
14998	110V Repl. Heat Element	
14981	220V Repl. Heat Element	
14999	Repl. Thermostat	

MYERS Nailhole Filler Extruder Gun

- Use from inside or outside the tire
- Adjustable thermostat
- Insulated heater stand warms barrel
- I-R Air motor
- Repair parts page 86



Use for filling nailholes before retreading. Extruded soft rubber flows into the nailhole and bonds to the carcass eliminating plugs. The electrically heated stand is controlled with a thermostat adjustable from 32°-248°F. Includes five nozzles. Requires 90-100 psi. Always use a patch to seal the innerliner. Available 110 or 220V.

Order No.	Description	Ship Wt.
14977	Myers Nailhole Extruder Gun 110V	12 lbs. - 5 kg
14978	Myers Nailhole Extruder Gun 220V	12 lbs. - 5 kg
14998	110V Repl. Heat Element	
14981	220V Repl. Heat Element	
14999	Repl. Thermostat	
15131	Myers Heater Box Only	
15132	Extruder Gun Only for Myers to Fit Heater Box	
15133	Extruder Gun Only for Bosch to Fit Heater Box	

TRIPLEMATIC Extruder Gun

- High output – 38 lb./hr.
- Repair parts page 86

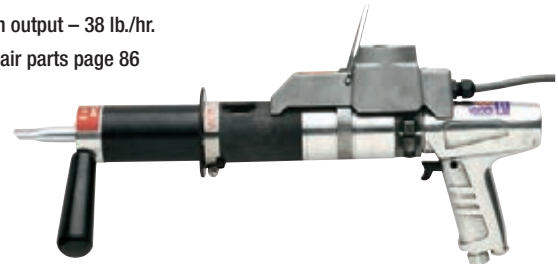

For heavy-duty, continuous use in the repair of the casings prior to retreading. Features a variable speed motor, an adjustable thermostat 150°-260°F., and hardened steel auger and barrel.

Order No.	Mfr. No.	Description	Ship Wt.
15128	HSG-48	Extruder 110V	12 lbs. - 5 kg
15130	HSG-48	Extruder 220 V	12 lbs. - 5 kg
15004	BL10	Tool Balancer	4 lbs. - 2 kg

OTR Extruder Gun

- Bosch air motor
- Delivers 61 lbs. per hour

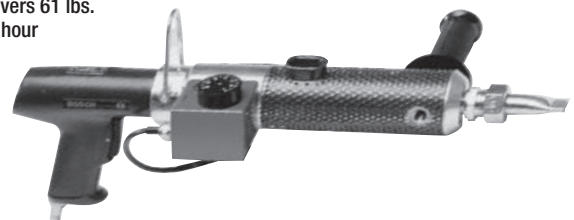

Built for heavy-duty, continuous use in the repair of off-the-road tires. Allows the tire technician maximum speed and output in performing buzz-out and section repairs of truck and O.T.R. tires. Thermostat is adjustable to 248°F. Powerful air motor, air consumption 28 cfm.

Order No.	Mfr. No.	Description	Ship Wt.
48672	687	Extruder 110V/220V Specify Voltage	11 lbs. - 5 kg

Tire Sealants

Tire Seal

- Seals bead leaks, slow leaks & punctures up to 1/4" in diameter
- Use for ATV, bicycles & lawn & garden

16 Ounce bottle includes valve core tool and filler tube. Not recommended for passenger vehicles.

Order No.	Description	Per Case
46055	Tire Seal 16 Oz. Bottle	24



Tire Seal

- For truck & agricultural tires
- Seals punctures up to 1/4"
- Prevents tire & tube rot



54531



56222
Optional Hand Pump



46051

When a puncture occurs, thousands of tiny fibers and rubber particles suspended in a fluid base penetrate the injury quickly to seal the puncture from the inside out. The formula also conditions the innerliner to prevent dry rot and cracking which may cause chronic slow leaks. Will not corrode wheels or rims. One application lasts the life of the tire. Resists freezing to -30°C.

Order No.	Mfr. No.	Description	Size	Ship Wt.
46060		Tire Seal	1 Gal.	10 lbs. - 5 kg
46869		Pallet of 24 Tire Seal	1 Gal.	240 lbs. - 109 kg
46051		Tire Seal	5 Gal.	46 lbs. - 21 kg
46868		Pallet of 24 Tire Seal	5 Gal.	1,104 lbs. - 501 kg
46054		Tire Seal	55 Gal.	520 lbs. - 234 kg
46871		Pallet of 2 Tire Seal	55 Gal.	1,040 lbs. - 472 kg
56222	XM120	Hand Pump for 5-Gal.		7 lbs. - 4 kg
56247	ST-XMI	Hand Pump for 1-Gal.		2 lbs. - 1 kg
54531		Valve Core Remover & Filler		1 lbs. - 1 kg

Tire Seal Liqui-Fill Concentrate

- For liquid filled agricultural tires

For use in tires weighted with calcium chloride, water or antifreeze. Install with hand pump before or after ballast is pumped into the tire. Use one gallon of Liqui-Fill concentrate to 30-gallons of ballast liquid.

Order No.	Description	Ship Wt.
46052	Liqui-Fill Concentrate - 5 Gallon	50 lbs. - 23 kg

Total II Tire & Wheel Protection

- Prevents wheel/rim rust & corrosion
- Prevents innerliner degradation & dry rot
- Extends tire service life

Designed to prevent rust and corrosion on steel wheels and rims. Reduces bead damage during mounting and dismounting of tires. Prevents innerliner degradation and dry rot by lubricating the tire innerliner. Aids in tire dismounting. Biodegradable and environmentally safe. Not recommended for use on Aluminum Wheels. Four gallons per case.



Order No.	Mfr. No.	Description	Size
46067		Total II	1 Gal.
46068	TOT-II-640	Total II	5 Gal.
46860	24-TOT11640	Pallet of 24 Total II	5 Gal.
46085	TOT-II-6G	Total II	6 Gal.
46861	24-TOT116G	Pallet of 24 Total II	6 Gal.
46069	TOT-II-55G	Total II	55 Gal.
46862	2-TOT115G	Pallet of 2 Total II	55 Gal.

OTR Tire Seal

- Keep expensive OTR tires on the job

Specially formulated for off-the-road tires. Repairs up to 1/4" punctures on the vehicle. Helps cool the tire and seal bead leaks. Recommended for tube type and tubeless tires. Will not corrode rims or wheels. One application lasts the life of the tire.

46056



Order No.	Mfr. No.	Description	Size	Ship Wt.
46064	OTRTS-1	OTR Tire Seal	1 Gal.	10 lbs. - 5 kg
46872	24-STSTRCS4128	Pallet of 24 OTR Tire Seal	1 Gal.	240 lbs. - 109 kg
46056	OTRTS-5	OTR Tire Seal	5 Gal.	50 lbs. - 22 kg
46863	24-STOTR640	Pallet of 24 OTR Tire Seal	5 Gal.	1,200 lbs. - 544 kg
46057	OTRTS-55	OTR Tire Seal	55 Gal.	550 lbs. - 249 kg
46865	2-STOTR55G	Pallet of 2 OTR Tire Seal	55 Gal.	1,100 lbs. - 499 kg

Tire Life & Tire Life Bag

Casing protection for passenger, truck and OTR. Reduces the major causes of casing damage; underinflation, heat build up, liner oxidation, air migration into the cord body and the rusting of steel plies in radial tires. Put the Tire Life "Bag" in the tire before mounting. For use in all non-balanced 10-22.5 through 11-24.5 tubeless truck tires.



46678

46673

Order No.	Description	Size	Ship Wt.
46673	Tire Life Bag (48 Per Carton)	20 oz.	1 lbs. - 1 kg
46678	Tire Life	1 gal.	9 lbs. - 5 kg
46675	Tire Life	55 gal. Drum	500 lbs. - 227 kg

Tire Leak Detector

Spray-on leak detector shows smallest leaks with mass of bubbles. Diluted concentrate is used in Sure-Shot Sprayer or other pressure sprayer over entire tire. Use for tires, on or off vehicle. Dilute 3 tablespoons with 1 quart or 6 ounces with 1 gallon of water.



56435

46618

Order No.	Mfr. No.	Description	Ship Wt.
46617	TT-150	1-Qt. Plastic Bottle	3 lbs. - 1 kg
46618	TT-151	1-Gallon Plastic Jug	9 lbs. - 4 kg
46619	TT-152	5-Gallon Pail	40 lbs. - 13 kg
46620		55-Gallon Drum	
56435	HPN-52D	Sure Shot Sprayer 1 Qt.	3 lbs. - 1 kg

EcoSeal High Temperature Tire Sealant

- For waste haul & commercial applications

Water base sealant designed to seal leaks in tires up to 1/4" in the crown area of the tire. The high pH levels prevent corrosion and damage found on wheels used with some sealants even after extensive high heat and cooling cycles.



Order No.	Mfr. No.	Description	Ship Wt.
56224		EcoSeal 5-Gallon Pail	50 lbs. - 23 kg
56225		EcoSeal 55-Gallon Drum	500 lbs. - 227 kg
56226		EcoSeal 275-Gallon Tote	2,560 lbs. - 1,161 kg
56222		5-Gallon Hand Pump	7 lbs. - 3 kg
56227	ST-XM-55	55-Gallon Transfer Pump	7 lbs. - 3 kg

Puncture & Section Repair

Myers Tire Supply is your Puncture & Section Repair headquarters. Whatever tools, supplies, & equipment are needed to repair a tire, Myers is your single source! We have high & low speed buffers/skivers from **MTS PNEUMATIC, CP, IR,** & **DOTCO** plus adapters & quick change chucks. Our assortment of hand tools include awls, probes, insert tools, scrapers & a complete line of **DEXTER-RUSSELL** knives. **MARKAL, BRITEMARK & MYERS TIRE SUPPLY** crayons are available in a multitude of colors. We stock high speed stones, solid carbide cutting tools, brushes & **L.R. OLIVER, B&J, RUBBERHOG, DUAL LIFE,** & **TEMCO** tire repair rasps. To cure the repair we offer **LINCOLN & WINNER** spotters & **VULCAN-VULCAP & MONAFLEX** curing systems.



Nailhole Leak Detector

- Use for detecting air leaks, separations & final inspection after repairs
- Includes 13"-16" expandable rim
- See page 302 for more expandable rims



Quickly checks for punctures in used tires. Inflatable rim allows operator to mount, inflate, check and demount tire in less than 30 seconds. Inflate to 25 psi, rotate the tire and spray with leak detector to find leaks fast. Includes **31031** expandable rim 6- $\frac{3}{8}$ " wide for 13"-16.5" tires, filter-regulator and auxiliary air tool connection. **31014** Features foot pedal operation. Requires 120 psi line pressure, $\frac{1}{4}$ " fpt. **Recommend:** Optional nickel plated piston and transfer tube.

Order No.	Mfr. No.	PSI	Qty./Box	Ship. Wt.
31016		25	Nailhole Leak Detector	375 lbs. - 169 kg
31014	TTR	25	Rotating Nailhole Leak Detector	375 lbs. - 169 kg
31017	TT	35	High Pressure Nailhole Leak Detector	375 lbs. - 169 kg

Tire Probing Awl



Special blunt duck bill tip will not damage cords while making repairs.

Order No.	Mfr. No.	Description	Blade Length
47016	TT-1140	Awl	3 $\frac{3}{4}$ "

Heavy-Duty Awl



Order No.	Mfr. No.	Description	Blade Length
47024	HD351	Heavy-Duty Awl	4 $\frac{1}{2}$ "

Pricking Awl

- With replaceable point



4" handle with chuck for changing points. Use to release trapped air from casing and to remove foreign objects from tire.

Order No.	Mfr. No.	Description	Blade Length
47000	K-80	Awl w/ Point	2 $\frac{1}{2}$ "
47001	K-80A	Replaceable Point	2 $\frac{1}{2}$ "

Tire Repair Hand Tools

Heavy-Duty T-Handle Reamer

Heavy-duty aluminum T-handle. Use to release trapped air from casing and to remove foreign objects from tire. Includes Allen wrench.

Order No.	Description	Blade Length
15092	Reamer T-Handle	4"
15093	Replacement Reamer Needle	

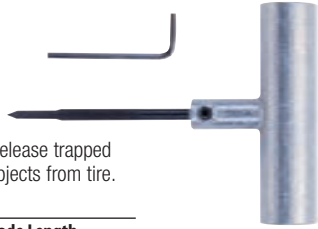

Heavy-Duty T-Handle Spiral Probe Cement Tool

Heavy-duty aluminum awl. Use to release trapped air from casing and to remove foreign objects from tire. Includes Allen wrench.

Order No.	Description	Blade Length
15089	Spiral Probe T-Handle	4 1/2"
15090	Replacement Spiral Probe	



Pistol Grip Probe/Rasp Tool

Use to determine the extent and angle of puncture injuries as well as reaming injuries.

Order No.	Mfr. No.	Description	Blade Length
15114	77	Pistol Grip Probe Rasp Tool	3 1/2"

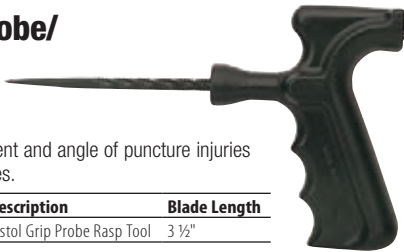

Pistol Grip Spiral Cement Tool

Designed to ream and apply cement to the walls of puncture injuries.

Order No.	Mfr. No.	Description	Blade Length
15115	78	Spiral Cement Tool	3 1/2"



Tire Reamers

The tire repairman's most useful tool in preparing tires for repair.

Order No.	Description	Dia.	Blade Length
15180	Tire Reamer	3/16"	6 5/8"
15181	Tire Reamer	1/4"	9"

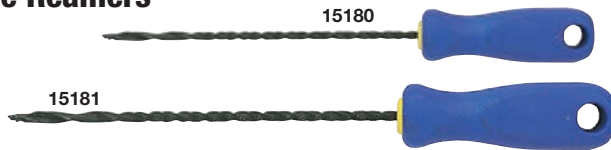

OTR Tools

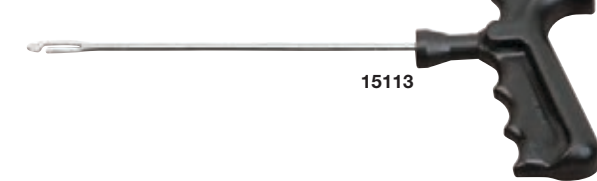

Order No.	Description	Blade Length
15113	Open Eye OTR Insert Tool	4 5/8"
15105	OTR Insert Tool	8"
15107	OTR Spiral Cement Tool	8"



Tire Repair Hand Tools

Open Eye Pistol Grip Tool

Order No.	Description	Blade Length
15113	Open Eye OTR Insert Tool	4 5/8"

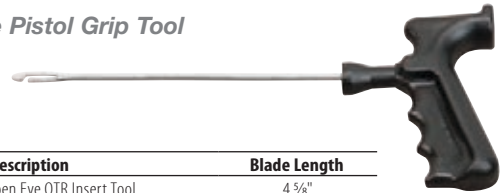

Closed Eye Pistol Grip Tool

Closed eye pistol grip insert tool for installing string in tubeless tire nailhole repairs.

Order No.	Description	Blade Length
15111	Closed Eye Insert Tool	3"



Split Eye Pistol Grip Tool

Split eye pistol grip insert tool for installing all types of inserts (plugs) flat, round and oval in passenger and truck tires.

Order No.	Description	Blade Length
15112	Split Eye Insert Tool	3"



Solid T-Handle Split Eye Tool

- Passenger & truck

Split eye T-Handle insert tool for installing all types of inserts flat, round and oval in passenger or truck tires. Includes Allen wrench.

Order No.	Description
15066	Passenger T-Handle with Needle
15067	Replacement Passenger Needle Split Eye
15069	Truck T-Handle with Needle
15070	Replacement Truck Needle Split Eye

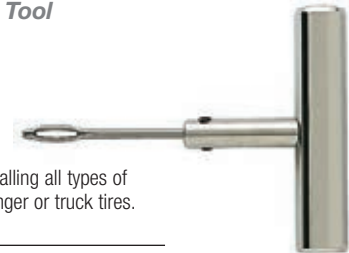

Heavy-Duty T-Handle Split Eye Tool

Heavy-duty aluminum split eye T-Handle insert tool. Includes Allen wrench.

Order No.	Description
15085	Split Eye Needle T-Handle
15086	Replacement Split Eye Needle

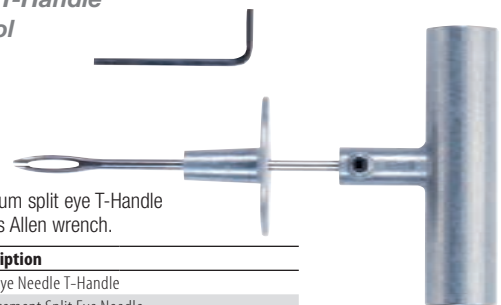

Innerliner Scraper

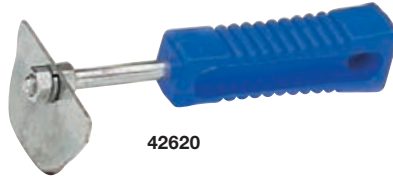

42620

For cleaning the innerliners for puncture and section repairs prior to buffing. Removes mounting lubricants, silicones etc. from the surface of the innerliner.

Order No.	Description	Length
42620	Innerliner Scraper	6"
97003	Economy Scraper	

Wire Cutting Drill Bit



For use in low speed grinder or drill motor. Cleans and contours puncture area.

Order No.	Mfr. No.	Description	Size Inches
42406	K370	Straight Shank Drill Bit	3/4"

Pull Thru Wires



For installing Plug Stems in tire injuries.

Order No.	Description	Length
14526	Pull Thru Wires	7"

Tire & Rim Brush



Wire brush part 6" long. Handle, 14", curved for easier use.

Order No.	Mfr. No.	Description
46020	TT-1132	Tire & Rim Brush

Brass Bristle Tire Brush



Use to clean the buffed innerliner before cementing and applying the repair unit. 8 x 9 rows on 8 1/2" x 2 5/8" handle.

Order No.	Mfr. No.	Description
46000	TD58R	Brass Bristle Brush

Industrial Shears



Straight Handle

Bent Handle

Heavy-duty large size shears with steel blades.

Order No.	Mfr. No.	Description	Size	Cut	Ship Wt.
42549	K-23	Straight Handle	10"	5"	1 lbs. - 1 kg.
42550	K-24	R.H. Bent Handle	10"	5"	1 lbs. - 1 kg.
42548	K-24	L.H. Bent Handle	10"	5"	1 lbs. - 1 kg.
42521	K-24A	Bent Handle	12"	6"	2 lbs. - 1 kg.

Roughener-Stitcher



Order No.	Mfr. No.	Description
42616	K-22A	For Tubeless Tires & Inner Tubes

Ball Bearing Stitcher & Rollers



- Other sizes available, contact us

Order No.	Mfr. No.	Description
Flat Edge		
42615	K-21A	2" x 1/2"
Serrated Edge		
42611	K-19	1 1/2" x 1/16"
42612	K-20	2" x 1/16"
42613	K-21	1 1/2" x 1/32"
42614	K-56	2" x 1/4"
42618	K-30	1 1/2" x 1/8"
42619	K-30	1 1/2" x 1/4"



Order No.	Mfr. No.	Description
42601	K-17	1 1/2" x 1 1/2" Flat
42602	K-18	2" x 2" Flat



Order No.	Mfr. No.	Description
42605	K-55D	2" x 2" Porcupine 7 Rows of Pins, 24 Per Row, 1/4" Ext.

Poly Handle Ball Bearing Stitchers

- Heavy duty handle & smooth ball bearing motion



42591

42592

42593

42594

Order No.	Equivalent To	Description
42591	K-19	1 1/2" x 1/16" Serrated Edge
42592	K-20	2" x 1/16" Serrated Edge
42593	K-56	2" x 1/4" Serrated Edge
42594	K-30	1 1/2" x 1/8" Serrated Edge

Knives

Taper Point Knife



Order No.	Mfr. No.	Blade Size
42502	K-2	4"

Flexible Blade Skiving Knives



Order No.	Mfr. No.	Blade Size
42500	K-1	4"
42501	K-1A	4 7/8"

Square Point Knives



Order No.	Mfr. No.	Blade Size
42503	K-3	4" x 1"
42504	K-4	6" x 1"
42506	K-5	8" x 1 1/2"

Curved Square Point Knife



Order No.	Mfr. No.	Blade Size
42508	K-10A	10" x 1 1/4"

Hawk Bill Knife



Order No.	Mfr. No.	Blade Size
42515	K-31	3 1/8"

Hawk Bill Notch Ply Knife



Order No.	Mfr. No.	Blade Size
42516	K-32	2"

Curved Point Scalpel Knife



Order No.	Mfr. No.	Description
42539	2M	Handle Only 4 1/4"
42546	2K	Blade Pkg of 10

Extra Curve Sharp Point Knife



Order No.	Mfr. No.	Blade Size
42509	K-6	3 3/8"

Bail Cutting Knife



Order No.	Mfr. No.	Description	Blade Size
42535	39714HGC	Knife with Guard	14"

Single End Mill Knives



Single end handle

Order No.	Mfr. No.	Description
42519	12SE	Handle, Holds 5/8" Blade
42520	34SE	Handle, Holds 3/4" (20.5 mm) Blade

Mill Blade



Blades

Order No.	Mfr. No.	Description
42523	12 Bevel	6" x 9/16" (152.5 x 14.3 mm) Blade for 12SE Handle
42525	42 Bevel	9" x 3/4" (228.5 x 20.5 mm) Blade for 34SE Handle

Double End Mill Knife



Handle for K-11A Blade

Order No.	Mfr. No.	Description
42511	K-11	Double End Handle

Mill Blade



Blade for double-end handle K11.

Order No.	Mfr. No.	Description	Blade Size
42512	K-11A	Blade 32 Bevel	9" x 5/8"

Fast Trim Vent Knife



Trim vent excess and mold flow from a retreaded tire in 15 seconds. Guide on the handle positions multi-grooved blade. Removable blade trims approximately 3,000 tires.

Order No.	Mfr. No.	Description	Ship Wt.
42527	K-55M	Handle & Blade (K55MB)	2 lbs. - 1 kg.
42528	K-55MB	Hi-Alloy Blades 9 Grooves, 1 7/8" Wide	1 lbs. - 1 kg.
42536	2030	Hi-Alloy Blades 3" Wide	

Notched Blade Trim Knives



Curved End Blade



Straight End

Order No.	Mfr. No.	Description
42517	K-10	Curved End Knife, 1 1/8" Notch Blade 4" x 1"
42533	K-7	Straight Blade, Five 1/8" Notches, Blade 6" x 1 1/2"

Super Sharpener

Hand held knife sharpener for tool box or shop. Properly sharpened knives and scissors increase efficiency and extends tool life.



Order No.	Mfr. No.	Description
37113	80	Knife Sharpener

Sharpening Stone



Flat stone with medium finishing for tire knives. 8" x 2" x 3/4".

Order No.	Mfr. No.	Description
37126	K-14	Sharpening Stone

Jet Rasp Sharpener



Order No.	Mfr. No.	Description	Ship Wt.
37132	57	Jet Rasp Sharpener	2 lbs. - 1 kg.

Electric Knife Heaters

- With thermostat



Surfaces cut with a hot knife have better tack. Eliminate the danger of moisture-induced separations. Used in rubber factories. Operating temperature range 290° to 300°. 115V 60 cycle element or 230V element available. U.L. listed.

Order No.	Mfr. No.	Volt	Knife Size		Ship Wt.
			In.	cm	
37104	K-36T	115V	6"	15	6 lbs. - 3 kg.
37094	K-36T	230V	6"	15	6 lbs. - 3 kg.
37105	K-37T	115V	8"	20	7 lbs. - 3 kg.
37095	K-37T	230V	8"	20	7 lbs. - 3 kg.
37106	K-38T	115V	10"	25	8 lbs. - 4 kg.
37096	K-38T	230V	10"	25	8 lbs. - 4 kg.

Insulated Heater Knives



Easiest & fastest way to cut rubber – used with electric knife heaters. Handle completely insulated, with sunken rivets to eliminate burns.



Order No.	Mfr. No.	Description	Size
42543	K-6S	Insulated Heater Knife	6"
42544	K-8S	Insulated Heater Knife	8"

Tape Measures



Order No.	Mfr. No.	Description
46737	W-616	6' Tape, 1/4" Blade
46723	W9212	12' Steel Tape
46736	K550	50' Steel Tape with Ring

Circumference-Diameter Tape with Claw



Easy-to-read raised markings in natural steel over black background. Brown leather case. One side in feet; inches and 8ths. Other side diameter equivalents of circumference in diameter feet and inches.

Order No.	Mfr. No.	Description
46740	261PTH	33' Circumference Diameter Tape with Claw
46747	261PTH-1	Refill
46739	263PTH	50' Circumference Diameter Tape w/Claw
46724	C106TPM	6.5m Metric Circumference Diameter Tape with Claw

Serial Number Remover/Defacer



Deface or remove the serial number. Blade included.

Order No.	Mfr. No.	Description
42920	TTHB-1	Tool with Blade
42921	RRB-1	Replacement Blade
42924	OTR Tool	OTR Tool
42925		Replacement Blade



Tire Marking

MARKAL® Paintstik®

- Permanent paint
- 13 Colors



Permanent, waterproof and fadeproof. Marks on wet tires or tires covered with mold lubricant. Withstands vulcanizing and retreading temperatures. Also marks on wood, plastic, glass, etc. Nontoxic, contains no lead. 3/4" O.D. Sold 12 per box. Note: Myers Paintstiks have a marking range of -50° F to 150° F.

Order No.	Mfr. No.	Description	Order No.	Mfr. No.	Description
45121	TD-60	White	45128	TD-60G	Pink
45122	TD-60A	Black	45129	TD-60H	Brown
45123	TD-60B	Red	45130	TD-60I	Gray
45124	TD-60C	Blue	45131	TD-60Y	Yellow
45125	TD-60D	Green	45132	TD-60J	Gold
45126	TD-60E	Orange	45133	TD-60K	Silver
45127	TD-60F	Purple			

MARKAL® "M" Series Paintstik

- Marks at room temperature, withstands to 1,600°F.



Will not come off in oil or water. Packaged 12 per box.

Order No.	Mfr. No.	Description	Color
45070	81920	High Temperature Paintstik Marker	White
45071	81921	High Temperature Paintstik Marker	Yellow

PAINTSTIK® Holders

- Aluminum holder prevents waste from breakage



For use with 3/4" Paintstiks listed above.

Order No.	Mfr. No.	Description
45134	101	5" Holder - 3/4" I.D.
45135	102	6" Push Button Holder - 3/4" I.D.

MARKAL® Fugitive Yellow Marker



Marks disappear during the heat of the retread process leaving no crayon marks on the tire when finished. Sold 12 per box.

Order No.	Description
45106	Fugitive Yellow Marker

MYERS Tire Marking Crayons



Doesn't melt, soften or rub off in the pocket. Marks on tires, tubes, rubber and plastic products. 3 7/8" x 1/2". Sold 12 per box.

Order No.	Mfr. No.	Description
45100	TD-1Y	Yellow
45102	TD-1W	White
45136	108	5" Holder 1/2" I.D.

Crayon Holder



Crayon Holder for 1/2" O.D. crayons, Myers

Order No.	Mfr. No.	Description
45136	108	5" Holder 1/2" I.D.

BRITE-MARK 40



Valve-action paint marker. Fine point marks easily on any surface. Sold each.

Order No.	Mfr. No.	Description
45110	40006	Yellow Brite-Mark 40
45111	40008	White Brite-Mark 40

LISTO Marking Pencil

- Writes on anything, metal, rubber, wood & glass



Sold 12 per box.

Order No.	Description
45060	Listo Marking Pencil
45061	Listo Marking Pencil Refills - 72 Per Box

Innerliner Markers



Non-petroleum base. Marks innerliner of tires to be repaired. Sold 12 per box.

Order No.	Description
45050	White China Marker

Silver Tire Marking Pen



Waterproof, easy to read silver ink. Grey body with silver cap and pocket clip.

Order No.	Description
45144	.4mm Medium Point Silver Tire Marking Pen - Sold Each

Air Tool Maintenance *Maximum Performance*

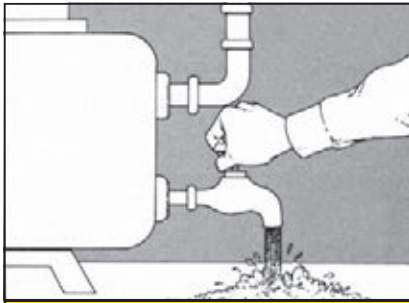

Drain Tank

• **Daily: Drain Tank & Air Line Filters.** Air under pressure condenses moisture in the bottom of the tank & throughout the air line system. Under average conditions of 75°F & 75% relative humidity, a compressor will take in about 18 gallons of water vapor a day! This moisture finds its way to your air tool, causing loss of power & premature tool failure.

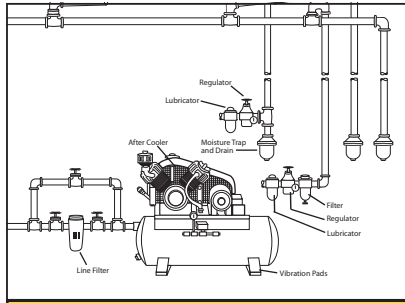

Install a Filter

• **Install a Filter - Regulator - Lubricator at each air tool outlet.** Some shop equipment requires only a filter-regulator unit. Check manufacturer's specifications. Shown above is a simple, dependable air system that will add life & efficiency to your air tools.

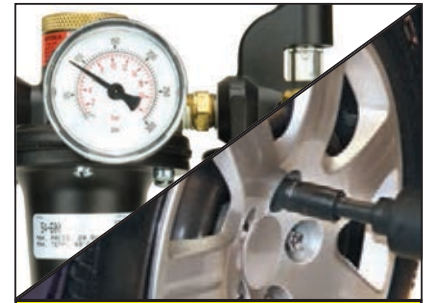

Check psi

• **Make Sure Your Compressor Is Up to the Job.** Impact tools usually require a minimum of 90 psi, maximum of 100 psi at the tool. Check manufacturer's recommendation. Check the air pressure at the tool while it's operating. An air leak you can hear is costing you money & your tools are losing power.

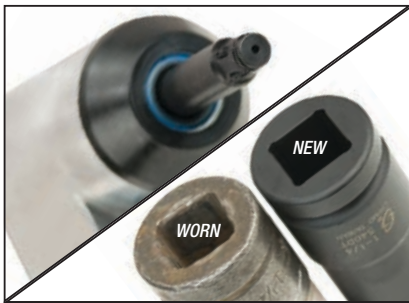

Warning Signs of Wear

• **Warning Signs of Wear.** Worn sockets or impact tool shanks drastically reduce tool life. When the beveled portions of the tip of the shank become worn, sockets don't fit correctly. A loose or sloppy fit quickly rounds the socket's opening. Old, rounded sockets on a new tool shank quickly damage the bevel for the same reason. Always purchase new sockets with a new wrench.



Oil Daily

• **Oil Daily.** The #1 contributing factor to air tool failure is lack of lubrication. Extend tool life. Squirt or drop an approved air tool oil (45206) directly into the tool whip hose or air inlet & run the tool for one or two seconds to disperse the oil in the tool. Oil tools at the beginning & end of the day.



Install a Whip Hose

• **Install a Whip Hose on Each Tool.** Never install a coupler directly to the air tool. Use a whip hose to reduce housing stress & add flexibility.

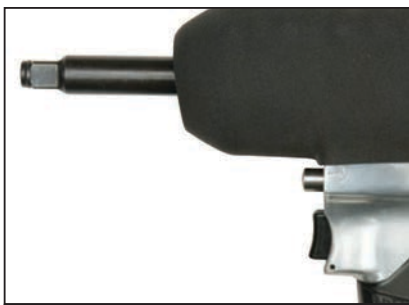

Keep Tools Clean

• **Keep Your Air Tools Clean.** A dirty tool results in power loss & shortened tool life. Inspect the air screens periodically. Use a protective tool cover to reduce damage caused by accidentally dropping & other abuse.



Don't Exceed Limit

• **Don't Exceed the Tool's Limit.** Use penetrating oil on rusted nuts. If an air tool does not loosen a bolt or nut in 3 to 5 seconds, stop. Use a penetrating lubricant (11053) & try again or if necessary, use a larger wrench.



Use a Conditioner

• **Use an Air Tool Conditioner.** Moisture evaporating in the tool while it's operating causes a calcium build-up. Air Tool Conditioner (45201) breaks the surface tension of the calcium & restores the tool to its normal power & speed. Use once per week or more often if the tool is used frequently.

Low Speed Buffers

IR Low Speed Buffer/Skiver Heavy-Duty

- 3,200 RPM
- For truck & earthmover tires
- Includes rear exhaust & whip hose



Optional
42415 Chuck

Lightweight, explosion-proof with geared head for powerful torque. Includes a rear exhaust hose to avoid contaminating the repair area. $\frac{3}{8}$ "-24 nf Spindle accommodates quick change chuck. Specs.: $\frac{3}{4}$ hp; 3,200 rpm; min. air hose $\frac{3}{8}$ "; air inlet $\frac{1}{4}$ " fpt; average air cons. 7 cfm; operating air pressure 90 psi.

Order No.	Mfr. No.	Description	Ship Wt.
31636	7LK	Heavy-Duty Buffer/Skiver	3 lbs. - 2 kg.
42415	TB-20C	Optional Quick Change Chuck	1 lbs. - 1 kg.
31649	MT-1	Replacement Exhaust Overhose	1 lbs. - 1 kg.
31640	7LTK1	Tune-Up Kit	1 lbs. - 1 kg.

DOTCO Low Speed Buffer

- 3,200 RPM
- Includes quick change chuck, 8' whip hose & 4' exhaust hose



Specs.: .3 hp; 3,200 rpm; min. air hose operating air pressure 90 psi. OSE $\frac{3}{8}$ "; air inlet $\frac{1}{4}$ " fpt;

Order No.	Mfr. No.	Description	Ship Wt.
31061	12L1092	Buffer with Chuck, Exhaust & Whip Hose	2 lbs. - 1 kg.
31064	45-2784	Repl. Whip Hose/Exhaust Kit for Composite Body	
31069	45-1931	Repl. Whip Hose/Exhaust Kit for Aluminum Body	

MYERS Lighted Low Speed Buffer

- 2,250 RPM
- Includes quick change chuck, rear exhaust & whip hose
- Air motor generates electricity & light for inside the tire



Replaceable lights increase visibility when working inside the tire. Use for innerliner preparation and reaming injuries before filling. Specs.: .4 hp; 2,250 rpm; min. air hose $\frac{3}{8}$ "; air inlet $\frac{1}{4}$ " fpt; average air cons. 3 cfm; operating air pressure 90 psi.

Order No.	Description	Ship Wt.
31663	Lighted Low Speed Buffer with Quick Change Chuck	3 lbs. - 2 kg.
31677	Replaceable Lights - Set of 3	

IR Low Speed Buffer

- 3,000 RPM
- Includes quick change chuck, 8' whip hose & 4' exhaust hose



Low speed buffer with $\frac{3}{8}$ " hex quick change chuck and rear exhaust hose. Specs.: $\frac{1}{2}$ hp; 3,000 rpm; min. air hose $\frac{3}{8}$ "; air inlet $\frac{1}{4}$ " fpt; average air cons. 14 cfm; operating air pressure 90 psi.

Order No.	Mfr. No.	Description	Ship Wt.
53221	IR327LS	Low Speed Buffer with Quick Change Chuck	3 lbs. - 2 kg.



Low Speed Buffer

- 2,600 RPM for innerliners, reaming & drilling
- Includes quick change chuck, rear exhaust & whip hose



Features a lever style throttle and a quick change chuck for fast rasp changing. 30" Rear exhaust hose directs air away from the repair area. 1-Year warranty. Specs.: 2,600 rpm; average air consumption 4 cfm; .5 hp; air inlet $\frac{1}{4}$ "; minimum hose size $\frac{3}{8}$ "; air pressure required 90 psi

Order No.	Description
31679	Low Speed Buffer

MYERS Low Speed Buffer

- 2,500 RPM for innerliners, reaming & drilling
- Includes quick change chuck, rear exhaust & whip hose
- Made in USA



Use for innerliner preparation and reaming injuries before filling. Specs.: .5 hp; 2,500 rpm; min. air hose $\frac{3}{8}$ "; air inlet $\frac{1}{4}$ " fpt; average air cons. 4 cfm; operating air pressure 90 psi.

Order No.	Description	Ship Wt.
31669	Low Speed Buffer with Quick Change Chuck	3 lbs. - 2 kg.

CP Low Speed Buffer Standard-Duty

- 2,500 RPM
- For innerliner buffing, reaming & drilling
- Includes rear exhaust & whip hose



Economical, low speed buffer with $\frac{3}{8}$ " hex quick change chuck and rear exhaust hose. Specs.: $\frac{1}{2}$ hp; 2,500 rpm; min. air hose $\frac{3}{8}$ "; air inlet $\frac{1}{4}$ " fpt; average air cons. 4 cfm; operating air pressure 90 psi.

Order No.	Mfr. No.	Description	Ship Wt.
31675	CP873	Buffer with Quick Change Chuck	2 lbs. - 1 kg.
53413	EX KT	Replacement Rear Exhaust Kit	1 lbs. - 1 kg.

Protective Eyewear

- Reduce the chance of eye injury from dust & debris



Scratch resistant and lightweight for comfort. Snug fit minimizes discomfort.

Order No.	Description
82664	Protective Eyewear with Clear Lens

Low Speed Buffer

- 4,000 RPM
- Includes quick change chuck, rear exhaust & whip hose
- For passenger, light truck tires & innerliners



Lever throttle geared head for powerful torque. Includes quick change chuck. *Specs.:* .60 hp; 4000 rpm; wheel/disc capacity dia. 3"; min. air hose 3/8"; air inlet 1/4" fpt; average air cons. 7 cfm; operating air pressure 90 psi.

Order No.	Mfr. No.	Description	Ship Wt.	
			lbs.	kg.
31672	533S	Low Speed Buffer/Skiver	3	1

DOTCO Low Speed Buffer

- 4,000 RPM
- Includes quick change chuck, 8' whip hose & 4' exhaust hose



Specs.: .3 hp; 4,000 rpm; min. air hose 3/8"; air inlet 1/4" fpt; operating air pressure 90 psi.

Order No.	Mfr. No.	Description	Ship Wt.
31063	15LF082	Grinder with Chuck, Exhaust & Whip Hose	2 lbs. - 1 kg.
31064	45-2784	Repl. Whip Hose/Exhaust Kit for Composite Body	
31069	45-1931	Repl. Whip Hose/Exhaust Kit for Aluminum Body	

IR Low Speed Buffer Medium-Duty

- 4,800 RPM
- Includes rear exhaust & whip hose



Optional
42415 Chuck

For passenger and light truck tires. 3/8"-24 nf spindle for a quick change chuck. *Specs.:* .45 hp; 5,500 rpm with 4,800 rpm free speed; min. hose size 3/8"; air inlet 1/4" fpt; average air cons. 7 cfm; operating air pressure 90 psi.

Order No.	Mfr. No.	Description	Ship Wt.
31648	SLJ	Low Speed Buffer/Skiver	2 lbs. - 1 kg.
42415	TB-20C	Optional Quick Change Chuck	1 lbs. - 1 kg.
31649	MT-1	Replacement Exhaust Overhose	1 lbs. - 1 kg.
31639	5LTK1	Tune-Up Kit	1 lbs. - 1 kg.

Replacement Exhaust Hoses

Order No.	Mfr. No.	Description
49014		1" Diameter Exhaust Hose 6' Long
49013		3/4" Diameter Exhaust Hose 6' Long
49011	IFC127211	Plastic Ring 1" Diameter



Whip Hoses



Length 24"

Order No.	Hose I.D.	MPT Ends	Order No.	Hose I.D.	MPT Ends
54150	1/4"	1/4"	54147	1/2"	1/4"
54145	3/8"	1/4"	54149	1/2"	3/8"
54146	3/8"	3/8"	54148	1/2"	1/2"

1/2" Reversible Air Drill

- With rear exhaust hose kit



Ideal for heavy drilling and plug cutting especially in truck tire treads. Reverse switch on side near trigger and auxiliary handle. *Specs.:* include: 1/2" jacobcs chuck; 1/2 hp motor; 500 rpm; avg. air consumption 4 cfm; air inlet 1/4"; min. hose size 3/8".

Order No.	Mfr. No.	Description	Ship Wt.
31200M	527	1/2" Reversible Drill	3 lbs. - 2 kg.
53413		Rear Exhaust Kit	1 lbs. - 1 kg.

See page 31 for Carbide Cutting Tools

MYERS Combination Buffer/Reamer

- Variable speed up to 20,000 RPM
- Includes rear exhaust & whip hose & 3/8" Jacobs chuck
- Made in USA



Variable speed tool can be used as a buffer or high speed reamer. Rear directed exhaust hose, 3/8" Jacobs chuck. *Specs.:* 20,000 rpm; .5 hp; min. air hose 3/8"; air inlet 1/4" fpt, average air cons. 4 cfm; operating air pressure 90 psi; 3/8"-24 spindle.

Order No.	Mfr. No.	Description	Ship Wt.
31674	SLP-4038	Combination Buffer/Reamer	2 lbs. - 1 kg.
31676	SLP-9801	Repair Kit	1 lbs. - 1 kg.

Buffer Specifications

- Low Speed 0 - 5,000 RPM - for Buffing Rubber
- High Speed 5,000 RPM & Higher - for Wire Cord

Low Speed Buffer Comparison Chart

Order No.	Free Sp. RPM	HP	Air Inlet	Min Air Hose	Average Air Cons.	Air Pres. Req.
31663	2,250	.4	1/4"	3/8"	3 cfm	90 PSI
31675	2,500	.5	1/4"	3/8"	4 cfm	90 PSI
31669	2,500	.5	1/4"	3/8"	4 cfm	90 PSI
31679	2,600	.5	1/4"	3/8"	4 cfm	90 PSI
53221	3,000	.5	1/4"	3/8"	14 cfm	90 PSI
31636	3,200	.75	1/4"	3/8"	7 cfm	90 PSI
31061	3,200	.3	1/4"	3/8"	4 cfm	90 PSI
31648	4,800	.45	1/4"	3/8"	7 cfm	90 PSI
31063	4,000	.3	1/4"	3/8"	4 cfm	90 PSI
31064	4,000	.3	1/4"	3/8"	4 cfm	90 PSI
31672	4,000	.60	1/4"	3/8"	7 cfm	90 PSI

High Speed Buffer Comparison Chart

Order No.	Free Sp. RPM	HP	Air Inlet	Min Air Hose	Average Air Cons.	Air Pres. Req.
31673	20,000	.5	1/4"	3/8"	4 cfm	90 PSI
31674	20,000	.5	1/4"	3/8"	4 cfm	90 PSI
31668	20,000	.5	1/4"	3/8"	4 cfm	90 PSI
31666	20,000	.5	1/4"	3/8"	3 cfm	90 PSI
31667	22,000	.5	1/4"	3/8"	4 cfm	90 PSI
31060	30,000	.3	1/4"	1/4"	4 cfm	90 PSI
52981	30,000	.5	1/4"	3/8"	15 cfm	90 PSI
31642	20,000	.3	1/4"	3/8"	3 cfm	90 PSI

High Speed Buffers

MYERS High Speed Buffer

- 20,000 RPM for trimming wire cord
- With quick change or Jacobs chuck
- Includes rear exhaust & whip hose
- Made in USA



For use with high speed grinding stones. Includes throttle lever. *Specs.: .5 hp; 20,000 rpm; min. air hose 3/8"; air inlet 1/4" fpt; average air cons. 4 cfm; operating air pressure 90 psi.*

Order No.	Description	Ship Wt.
31673	High Speed Buffer with Quick Change Chuck	3 lbs. - 2 kg.
31674	High Speed Buffer with Jacobs Chuck	3 lbs. - 2 kg.

MYERS High Speed Buffer

- 20,000 RPM for trimming wire cord
- 1/4" Collet
- Includes rear exhaust & whip hose
- Made in USA



For use with high speed grinding stones. Includes throttle lever, two wrenches, and 1/4" collet. Optional 1/8" collet available. *Specs.: .5 hp; 20,000 rpm; min. air hose 3/8"; air inlet 1/4" fpt; average air cons. 4 cfm; operating air pressure 90 psi.*

Order No.	Description	Ship Wt.
31668	High Speed Buffer with 1/4" Collet	2 lbs. - 1 kg.
31678	Optional 1/8" Collet	

MYERS Mini High Speed Buffer

- 20,000 RPM for trimming wire cord
- 1/4" Collet
- Includes rear exhaust & whip hose
- Made in USA



For use with high speed grinding stones. Includes throttle lever, two wrenches, and 1/4" collet, optional 1/8" collet available. *Specs.: .3 hp; 20,000 rpm; min. air hose 3/8"; air inlet 1/4" fpt; average air cons. 3 cfm; operating air pressure 90 psi.*

Order No.	Description	Ship Wt.
31666	Mini High Speed Buffer with 1/4" Collet	1 lbs. - 1 kg.
31678	Optional 1/8" Collet	

Right Angle High Speed Buffer

- 20,000 RPM for trimming wire cord
- Includes rear exhaust & whip hose



Makes grinding of wire cord inside the tire easier. Lever throttle controls tool speed from 0 to 20,000 rpm. Rear exhaust and overhose avoids contamination to work area. *Specs.: 1/4" collet chuck, 20,000 rpm, min. hose size 3/8", air inlet 1/4" mpt, average air cons. 3 cfm, operating pressure 90 psi.*

Order No.	Mfr. No.	Description	Ship Wt.
31642	AP5201	Right Angle Grinder	3 lbs. - 2 kg.
31661	C-18	Optional 1/8" Collet	1 lbs. - 1 kg.

CP High Speed Buffer

- 22,000 RPM for trimming wire cord
- Includes rear exhaust & whip hose



Precision made for clean, quick grinding of wire cord. Lever throttle controls wide range of speeds. Rear exhaust and overhose helps avoid contamination of repair area. *Specs.: 1/2 hp, 22,000 rpm, minimum hose size 3/8", air inlet 1/4" mpt, average air consumption 4 cfm, operating pressure 90 psi.*

Order No.	Ref. No.	Description	Ship Wt.
31667	CP872	High Speed Grinder	11 lbs. - 5 kg.
31661	C-18	Optional 1/8" Collet	1 lbs. - 1 kg.

DOTCO High Speed Buffer

- 30,000 RPM for trimming wire cord
- Includes 4' exhaust & 8' whip hose



Includes 1/4" collet, 8' whip hose and 4' exhaust hose. *Specs.: .3 hp; 30,000 rpm; min. air hose 3/8"; air inlet 1/4" fpt; operating air pressure 90 psi.*

Order No.	Mfr. No.	Description	Ship Wt.
31060	12L1080-36	Buffer Complete	2 lbs. - 1 kg.
31064	45-2784	Repl. Whip Hose & Exhaust Hose Kit for Composite Body	1 lbs. - 1 kg.
31066	304	1/8" Collet	1 lbs. - 1 kg.
31069	45-1931	Repl. Whip Hose & Exhaust Hose Kit for Aluminum Body	1 lbs. - 1 kg.
31067	14-0807	Replacement 7/16" Collet Wrench	1 lbs. - 1 kg.
31068	14-0811	Replacement 13/16" Collet Wrench	1 lbs. - 1 kg.
31059	308	Replacement 1/4" Collet	1 lbs. - 1 kg.

IR High Speed Buffer

- 22,000 RPM
- Lever throttle
- Includes quick change chuck, 8' whip hose & 4' exhaust hose



Use with high speed stones and carbide cutting tools to trim steel cord. *Specs.: 1/2 hp; 22,000 rpm; min. air hose 3/8"; air inlet 1/4" fpt; average air cons. 15 cfm; operating air pressure 90 psi.*

Order No.	Mfr. No.	Description	Ship Wt.
52981	IR327	High Speed Buffer with Jacobs Chuck	3 lbs. - 2 kg.
54145		Optional 2' Whip Hose 3/8" I.D. with 1/4" MPT Ends	1 lbs. - 1 kg.
49014		Optional 1" Dia. Exhaust Hose	1 lbs. - 1 kg.

Air Tool Conditioner

- For all piston-type & rotary air tools

Moisture evaporating in the tool while it's operating causes a calcium build-up. Air Tool Conditioner breaks the surface tension of the calcium and restores the tool to its normal power and speed. Use once per week or more often if the tool is used frequently.

Order No.	Description	Size
45201	Air Tool Conditioner	12.2 oz. Can



URYU Heavy-Duty High Speed Passenger/Truck Buffer/Skiver

- 14,600 RPM for innerliners, tread & shoulder areas



Powerful tool for fast buffing/skiving. Muffled rear exhaust, lever throttle to control various speeds, and heavy-duty four bearing construction for long life. Tool has 3/8" - 24 nf spindle to accommodate quick change chuck. *Specs.: .60 hp, 14,600 rpm, wheel capacity diameter 2 1/2", minimum air hose 3/8" air inlet 1/4" fpt, average air consumption 7 cfm, operating air pressure 90 psi.*

Order No.	Mfr. No.	Description	Ship Wt.
31684	UG-65EBL	High Speed Buffer/Skiver	4 lbs. - 2 kg.
42204	K-354	Rasp - 3/4" W., 2" Dia. 36 Grit 3/8" A.H	1 lbs. - 1 kg.
42415	TB20C	Optional Quick Change Chuck	1 lbs. - 1 kg.

URYU OTR Buffer/Skiver Cup Cutter

- 7,200 RPM for OTR tires
- Includes side exhaust hose & rear whip hose

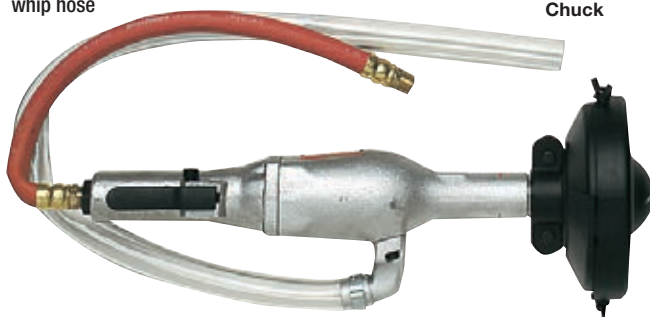

Powerful tool handles heavy jobs. Governor-controlled motor, lever throttle controls wide range of speeds, and muffled rear exhaust. Tool has 1/2"-13 nf spindle. *Specs.: 1.2 hp, 7,200 rpm, wheel capacity diameter 5", minimum air hose 1/2", air inlet 3/8" fpt, average air consumption 11 cfm, operating air pressure 90 psi.*

Order No.	Mfr. No.	Description	Ship Wt.
31688	UG-1250-LM	OTR Buffer/Skiver/Cup Cutter	9 lbs. - 4 kg.
42291	TCW-515	Tungsten Carbide Contour Wheel - 5" Dia., 1/2" A.H. 23 Grit (for Innerliner Buffing)	2 lbs. - 1 kg.
42493	TDW-5118	Tungsten Carbide Round-Faced Wheel - 5" Dia., 1/2" A.H., 16 Grit (for Skiving)	2 lbs. - 1 kg.
42424	MQC-2-13	1/2"-13 Optional Quick Change Chuck	1 lbs. - 1 kg.

IR Angle Grinder

- 5,000 RPM



Use for finishing sidewalls on OTR tire repairs. *Specs.: max. free speed 5,000 rpm; pad dia. 7"; output 3/8" - 11 thread; , minimum air hose 3/8" air inlet 1/4" fpt, aver. air cons. 8 cfm; aver. air cons. @ load 29 cfm; ship. wt. 4 1/2 lbs.*

Order No.	Mfr. No.	Description	Ship Wt.
52986	IR313A	Angle Grinder	6 lbs. - 3 kg.

Quick Change Chuck & Adapters



Use any of the adapters listed with the 42415 chuck. Rasps and other repair tool accessories mounted on the proper adapters make a quick and efficient system of performing professional repairs.

Order No.	Mfr. No.	Description
42415	TB-20C	Quick Change Chuck (3/8" - 24 FPT)
42424	MQC-2-13	Quick Change Chuck (1/2" - 13 FPT)
42365		5/16" - 18 Quick Change Chuck (5/16" - 18 FPT)
42420	TB-4	3/8" - 24 Adapter, 2 1/4" Long
42421	TB-4A	3/8" - 24 Adapter 1" Long Thread, 2 1/4" Length w/ 2 Washers, Nut for Mounting Tools w/ 3/8" Arbor Hole
42422	TB-4S	3/8" - 24 Short Adapter 1 7/8" Long
42497	TB-3AH	1/4" Shaft Adapter with Set Screw
42498	TB-3BH	1/4" Shaft Adapter with Set Screw
42375	2540	3/16" 3 Tang Shank Adapter with set screw
42376	2541	5/16" 3 Tang Shank Adapter with set screw
42370	CC	7/16" & 3/8" Shank Adapter w/set screw
42399	TB-4B	Quick Change Adapter with Spacer
42412		Double Adapter for Skiving Brush
42425L		1/2" Double Quick Change Adapter with Nut
49635		5/32" x 3/16" Set Screws for 42497, 42498, 42375, 42376 Adapters. 25 Per Bag

Jacobs Chucks & Adapters

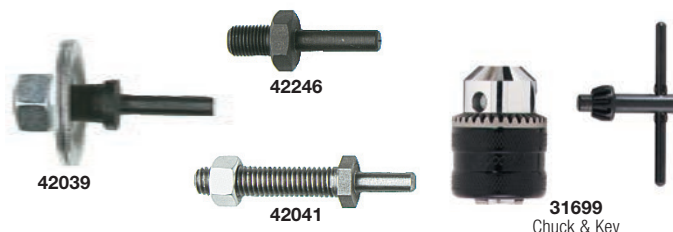

Order No.	Mfr. No.	Description
31699	30247	3/8" Chuck & Key (3/8"-24 Thread)
42039	TB-310-D	1/4" Shank to 1/2" SAE Male
42041	TB-320-D	1/4" Shank to 3/8" USS Male
42246	K-345	For 1/4" Drill to 3/8" USS Male
42413		1/4" Shank to 3/8" SAG Male (Not Shown)

Flexible Shaft Lubricant

For smooth running, cores need light lubrication about every 50 hours of operation.

Order No.	Mfr. No.	Description
45214	514-B	14 oz. Flexible Shaft Lubricant



Flexible Shaft Buffers

Flexible Shaft & Drill Adapters

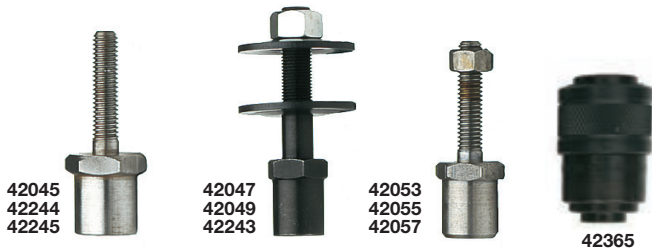

Adapters		
Order No.	Mfr. No.	Description
42045	TB-310-R	Special 1/2" (12.7mm) SAE F, 3/8" (9.1mm) USSM
42244	TB-313	For Sioux 3/8" - 16 USS F, 3/8" - 24M
42245	TB-314	Special 1/2" - 20 SAE F, 3/8" - 24M
Wheel Arbor With Flanges		
42047	TB-505-A	For Wyco 5/8" - 18 SAE F, 1/2" 20M
42049	TB-505-D	Bell 1/2" (12.7mm) SAE F, 3/8" (9.1mm) USSM
42243	TB-305R	For Wyco 5/8" - 18 SAE F, 3/8" 24M
Wheel Arbor Without Flanges, With Nuts		
42053	TB-5B	Special 1/2" (12.7mm), SAE F, 3/8" (9.1mm) USSM
42055	TB-5C	Special 1/2" (12.7mm), SAE F, 1/2" (12.7mm) SAEM
42057	TB-5D	Sioux 3/8" (9.1mm) USS F, 1/2" (12.7mm) SAEM
42365		For Wyco 5/8" - 18 FPT Quick Change

WYCO Flexible Shaft Buffers



Use grinding wheels, wire brushes, tire rasps, etc. for various grinding and buffing operations. Quick-change hand pieces snap on and off quickly and easily. All welded steel. Motors are capacitor type, constant speed, 115/ 230V, single phase, 60 cycle A.C. with toggle switch, and 7 ft., 3-wire cord and safety plug. Shipped knocked down in carton. Includes one hand piece, one set of wheel arbors and one set of wrenches.

Order No.	Mfr. No.	HP	Speed R.P.M.	Ship Wt.
31440	49-2	1/3	1725	60 lbs. - 27 kg.
31442	49-4	1/2	1725	65 lbs. - 30 kg.
31441	49-3	1/2	3450	55 lbs. - 25 kg.
31444	49-6	3/4	1725	75 lbs. - 34 kg.
31443	49-5	3/4	3450	65 lbs. - 30 kg.
31445	49-14	1	3450	85 lbs. - 38 kg.

WYCO Buffer Flexible Shaft Replacement Chart

- For Use with any Wyco Buffer

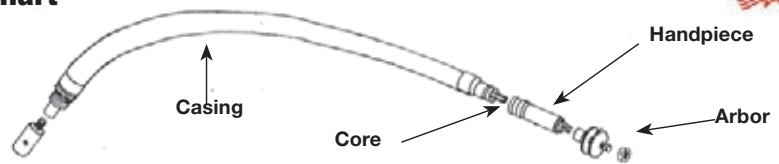

See above for flexible shaft adapters

Complete Flexible Shaft Assembly Includes core, casing and handpiece NO MOTOR COUPLING				Core Only			Casing Only		Handpiece Only		Optional Universal Motor Coupling Only		Optional Wyco Wheel Guards Only		
Order No.	Mfr. No.	Machine Mfr. No.	Length Feet	Order No.	Mfr. No.	End Type	Order No.	Mfr. No.	Order No.	Mfr. No.	Order No.	Shaft Size	Mfr. No.	Order No.	Mfr. No.
31449	10R Shaft	49-2	5	31463	C-10	Male	31470	K-10	31498	3500	31500C	5/8"	3400	31427	414
31450	2R Shaft	49-3	6	31464	C-2	Male	31471	K-2	31498	3500	31500C	5/8"	3400	31427	414
31450	2R Shaft	49-4	6	31464	C-2	Male	31471	K-2	31498	3500	31500C	5/8"	3400	31427	414
31451	30R Shaft	49-5	7	31465	C-30	Female	31472	K-30	31499	551	31501C	5/8"	550MP	31426	5576
31451	30R Shaft	49-6	7	31465	C-30	Female	31472	K-30	31499	551	31501C	5/8"	550MP	31426	5576
31455	4R Shaft	49-14	7	31456	C-4	Female	31457	K-4	31499	551	31501C	5/8"	550MP	31426	5576

Non-Wyco Buffer Flexible Shaft Replacement Chart

- For Any Standard Motor – Not for Wyco

See above for flexible shaft adapters

Complete Universal Flexible Shaft Assembly. Includes core, casing, handpiece and motor coupling			Core Only			Casing Only		Handpiece Only		Universal Motor Coupling Only			
Order No.	Shaft Complete w/Motor Coupling	Mfr. No.	Length Feet	Order No.	Mfr. No.	End Type	Order No.	Mfr. No.	Order No.	Mfr. No.	Order No.	Motor Shaft	Mfr. No.
31115B	1.) With 1/2" Coupling	01	5	31125	C-01	Male	31135	K-01	31124	251-N	N.A.	1/2"	2400
31115C	1.) With 5/8" Coupling	01	5	31125	C-01	Male	31135	K-01	31124	251-N	N.A.	5/8"	2400
N.A.	2.) With 1/2" Coupling	10	5	31463	C-10	Male	31470	K-10	31498	3500	31500B	1/2"	3400
N.A.	2.) With 5/8" Coupling	10	5	31463	C-10	Male	31470	K-10	31498	3500	31500C	5/8"	3400
31117B	3.) With 1/2" Coupling	02	5	31127	C-02	Male	31137	K-02	31498	3500	31500B	1/2"	3400
31117C	3.) With 5/8" Coupling	02	5	31127	C-02	Male	31137	K-02	31498	3500	31500C	5/8"	3400
31119B	3.) With 1/2" Coupling	2	6	31464	C-2	Male	31471	K-2	31498	3500	31500B	1/2"	3400
31119C	3.) With 5/8" Coupling	2	6	31464	C-2	Male	31471	K-2	31498	3500	31500C	5/8"	3400
31121C	4.) With 3/8" Coupling	30	7	31465	C-30	Female	31472	K-30	31499	551	31501C	5/8"	550MP
31121D	4.) With 1/2" Coupling	30	7	31465	C-30	Female	31472	K-30	31499	551	31501D	3/4"	550MP
N.A.	5.) With 5/8" Coupling	4	7	31456	C-4	Female	31457	K-4	31499	551	31501C	5/8"	550MP
N.A.	5.) With 3/4" Coupling	4	7	31456	C-4	Female	31457	K-4	31499	551	31501D	3/4"	550MP

NOTE: 1.) 31115B&C - Mfr. No. #01 Complete Shaft Assembly for use usually with Light Duty Buffers 2.) Mfr. No. #10 Complete Shaft assembly for use with 1/4hp & 1/4hp Motors 3.) 31117B&C & 31119B&C - Mfr. No. #02 and #2 Complete Shaft assemblies for use with 1/4hp Motors 4.) 31121 - Mfr. No. #30 Complete Shaft assembly for use with 3/4 hp Motors 5.) Mfr. No. #4 Complete Shaft assembly for use with 1 hp & 1-1/2 hp Motors

Wire Cutting Solid Carbide Cutting Tools

- Use with proper eye protection see page 26

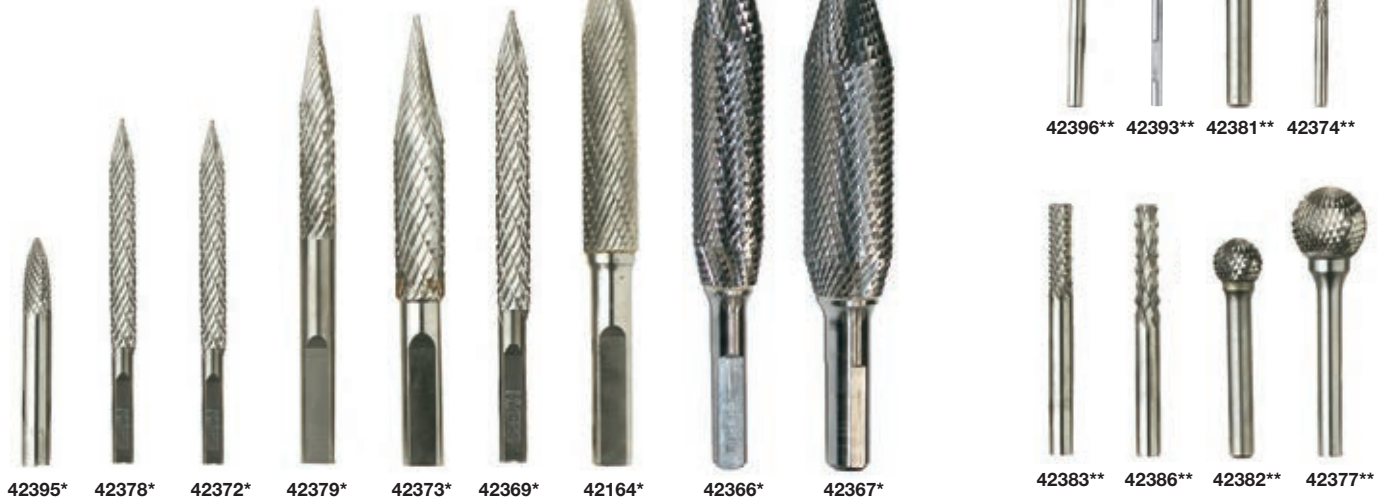

* Best results obtained using a 500 to 1,200 rpm maximum buffer. 42394** Made in China

Order No.	Description	Size	Shank Size	Length	Use Adapter
42396**	Pencil Point	1/8"	1/8"	1 1/2"	42497
42393**	Long Pencil Point	1/8"	1/8"	2 1/2"	42497
42394**	Value Long Pencil	1/8"	1/8"	2 1/2"	
42395**	Pencil Point	1/4"	1/4"	2"	42498
42380	Value Long Pencil	1/4"	1/4"	2"	42498
42378*	Extended Point	3/16"	3/16" 3 Tang	3"	42375
42372*	Extended Point	6mm	3/16" 3 Tang	76mm	42375
42379*	Extended Point	5/16"	5/16" 3 Tang	4"	42376
42373*	Extended Point	7/16"	7/16" 3 Tang	4"	42370
42369*	Extended Point	9mm	5/16" 3 Tang	100mm	42376

** Best results obtained using a 20,000 to 30,000 rpm maximum buffer

Order No.	Description	Size	Shank Size	Length	Use Adapter
42164*	Extended Point	1/2"	3/8"	5"	42370
42366*	Extended Point	3/4"	3/8"	6"	42370
42367*	Extended Point	1"	1/2"	6"	N/A
42381**	Short Point	3/8"	1/4"	2 3/4"	42498
42374**	Flat Head Router	1/8"	1/8"	1 1/2"	42497
42383**	Flat Router – Fine	1/4"	1/4"	2 1/2"	42498
42386**	Flat Router – Coarse	1/4"	1/4"	2 1/2"	42498
42382**	Round Ball	1/2"	1/4"	2 1/2"	42498
42377**	Round Ball	3/4"	1/4"	2 3/4"	42498

Wire Cord High Speed Grinding Stones

- Use with proper eye protection see page 26

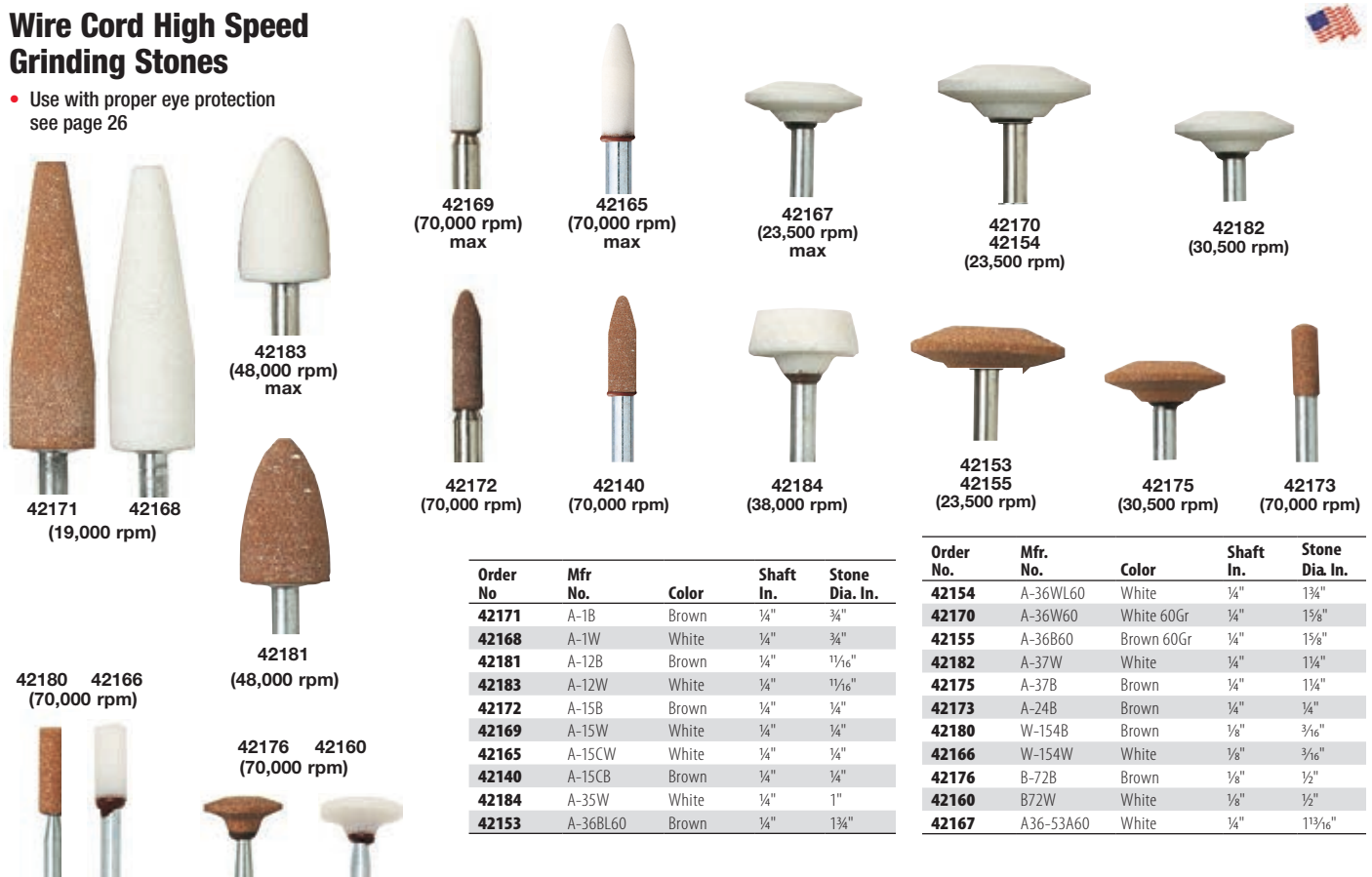

Order No.	Mfr No.	Color	Shaft In.	Stone Dia. In.
42171	A-1B	Brown	1/4"	3/4"
42168	A-1W	White	1/4"	3/4"
42181	A-12B	Brown	1/4"	1 1/16"
42183	A-12W	White	1/4"	1 1/16"
42172	A-15B	Brown	1/4"	1/4"
42169	A-15W	White	1/4"	1/4"
42165	A-15CW	White	1/4"	1/4"
42140	A-15CB	Brown	1/4"	1/4"
42184	A-35W	White	1/4"	1"
42153	A-36BL60	Brown	1/4"	1 3/4"

Order No.	Mfr No.	Color	Shaft Dia. In.	Stone Dia. In.
42154	A-36WL60	White	1/4"	1 3/4"
42170	A-36W60	White 60Gr	1/4"	1 5/8"
42155	A-36B60	Brown 60Gr	1/4"	1 5/8"
42182	A-37W	White	1/4"	1 1/4"
42175	A-37B	Brown	1/4"	1 1/4"
42173	A-24B	Brown	1/4"	1/4"
42180	W-154B	Brown	1/8"	3/16"
42166	W-154W	White	1/8"	3/16"
42176	B-72B	Brown	1/8"	1/2"
42160	B72W	White	1/8"	1/2"
42167	A36-53A60	White	1/4"	1 13/16"

Rasps

MYERS Tungsten Carbide Rasps

Myers specially coated tungsten carbide rasps are ideal for buffing, skiving, and finishing rubber, plastic, fiberglass, wood, or any non-metallic material. The tungsten carbide rasp cuts cleaner, quicker and at a lower cost. Use 36 grit and up for rubber finishing and cleaning and 16 grit for buffing, skiving, and cutting. *Save money. Myers Tungsten Carbide Rasps can be regritted. New tungsten carbide grit bonded to an old worn rasp provides a new rasp surface.*

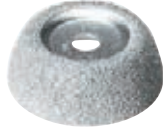

LR OLIVER Rubberhog SSG Carbides

Rubberhog carbides have a coating of randomly spaced sharp uniform conical teeth made from a very hard tungsten carbide material. It is the combination of the sharpness of the teeth, with the uniform height and shape of the teeth, that gives the Rubberhog rasp a fast, cool, superior buff texture resulting in a longer rasp service life.

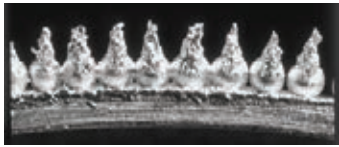

MCM	Description
120	Very Coarse
90	Coarse
70	Medium

SSG	Std. Grit
550	12
460	12
390	16
330	24
230	36
170	60
110	100

Comparison tooth size to standard carbide grit designation

MYERS Dualife Tungsten Carbide Rasps

The Myers Dualife rasp is an extended life tungsten carbide rasp for buffing and finishing tires. Dualife carbide rasps offers two to three times the life of a conventional carbide rasp.

- Sharper edges mean faster and cooler cutting, greatly improving durability
- Sharper carbide means cooler buffing and less chance for burning the buffed area
- Silver color identifies the rasp as the Myers longer life Dualife carbide rasp



B&J Jensen Tungsten Carbide Rasps

These rasps eliminate the need to handle cores.

The Jensen tungsten carbide product line is designed as a premium disposable carbide, always a new tool in use. The Jensen carbide is a disposable sharp-edged premium carbide offering long service with a consistent buff texture.



Arbor & Grit

Some of the tungsten carbide rasps may be ordered in varying arbor holes and grit specifications. By adding the proper letter after the 5 digit Myers Order Number. Specify the grit by adding the proper number after the arbor hole letter. For example 38211C3 is a 4" diameter, 3/8" arbor hole; 36 grit Cup Curved Rasp.

Arbor Hole	Grit
A = 3/8" AH	1 = 16 Grit
B = 1/2" AH	2 = 24 Grit
C = 5/8" AH	3 = 36 Grit
	4 = 46 Grit
	6 = 60 Grit

Note:

Use 36 grit and up for rubber finishing and cleaning
Use 16 grit for buffing, skiving, and cutting.

Flat Faced Rasps

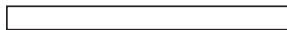

Vented & Non-Vented Contour Cup Rasp

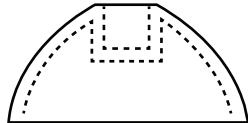

Vented Radiused Cup Rasps

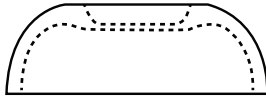

Radiused Faced Rasps



Non-Vented Radiused Cup Rasps

- Solid with heavy-duty machined core.
3/8"-24 threaded arbor hole



Vented & Non-Vented Curved Cup Rasps

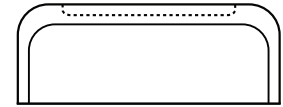

RUBBERHOG Extreme Disc Wheel



Order No.	Mfr. No.	Diameter		Arbor Hole		Color	MCM
		In.	mm	In.	mm		
43315	SD412 x 120	4 1/2"	114.3	7/8"	22.2	Black	120
42819	SD412 x 90	4 1/2"	114.3	7/8"	22.2	Blue	90
42820	SD412 x 70	4 1/2"	114.3	7/8"	22.2	Teal	70

RUBBERHOG Extreme Dish Wheel



Order No.	Mfr. No.	Diameter		Arbor Hole		Color	MCM
		In.	mm	In.	mm		
42822	DW412 x 70	4 1/2"	114.3	7/8"	22.2	Teal	70
42821	DW412 x 90	4 1/2"	114.3	7/8"	22.2	Blue	90
42823	DW412 x 120	4 1/2"	114.3	7/8"	22.2	Black	120

RUBBERHOG Disc Wheel

- For angle head grinders



Order No.	Mfr. No.	Diameter		Arbor Hole		SSG
		In.	mm	In.	mm	
42816	SD4120390	4 1/2"	114	7/8"	22.2	390
43278	SD4120230	4 1/2"	114	7/8"	22.2	230
43279	SD4120550	4 1/2"	114	7/8"	22.2	550

RUBBERHOG Dish Wheel

- For angle head grinders



Order No.	Mfr. No.	Diameter		Arbor Hole		SSG
		In.	mm	In.	mm	
42757	DW4120390	4 1/2"	114	7/8"	22.2	390
42739	DW4120230	4 1/2"	114	7/8"	22.2	230
42783	DW4120550	4 1/2"	114	7/8"	22.2	550

RUBBERHOG Flared Contour Wheels



The working faces of the wheels are angled to the shaft making it easy to clear the hand piece for working inside and outside the casing. The wide and nearly flat working face radius produces the ideal texture over a wider contact area.

Order No.	Mfr. No.	Diameter		Width		Arbor Hole	SSG
		In.	mm	In.	mm		
42765	130-170	2"	51	¾"	19	¾"	170
42740	130-230	2"	51	¾"	19	¾"	230
42761	107	2 ½"	64	1"	25	¾"	170
42766	109	2 ½"	64	1 ¼"	27	¾"	230
42771	114	3"	76	1 ¼"	32	¾"	230
42772	116	3"	76	1 ¼"	32	¾"	390
42775	122	3 ½"	89	1 ½"	38	¾"	390
42759	118	3 ½"	89	1 ½"	38	¾"	170
42814	111	2 ½"	64	1 ¼"	27	¾"	390
42815	120	3 ½"	89	1 ½"	38	¾"	230
OLIRG100	100	1 ¾"	44	¾"	19	¾"	230
OLI102	102	1 ¾"	44	¾"	19	¾"	170

RUBBERHOG Flared Contour Wheel Polyplugs

Units are made for flared contour wheels and are reusable. The polyplugs make the wheels run true, protect them from damage and provide better control.

Order No.	Mfr. No.	Diameter		Arbor Hole
		In.	mm	
OL1150	150	1 ¾"	44	¾"
42779	151	2"	51	¾"
42760	152	2 ½"	65	¾"
42780	154	3"	76	¾"
42781	156	3 ½"	89	¾"



RUBBERHOG Contour Wheel for Bandag Buffers

- Regrit service available



A precision contour wheel for sidewall buffing attachments.

Order No.	Mfr. No.	Diameter		Width		Arbor Hole	SSG
		In.	mm	In.	mm		
42768	129-P	4"	102	1 ½"	38	¾"	390

RUBBERHOG Donut Wheel for Matteuzzi Buffers

- Reducer bushings available
- Regrit service available



For Matteuzzi RAS90, RAS98E, RAS98E Ultra and other sidewall buffing attachments. Special bushings required, contact us.

Order No.	Mfr. No.	Diameter		Width		Arbor Hole	SSG
		In.	mm	In.	mm		
42774	708	6"	152	1"	25	1 ½" (38mm)	390
	707-50	6"	152	1"	25	2" (50mm)	460
	708-50	6"	152	1"	25	2" (50mm)	390
42785	711	8"	203	1 ¼"	32	2 ¾" (60mm)	390

RUBBERHOG Round Faced Buzzout Wheel

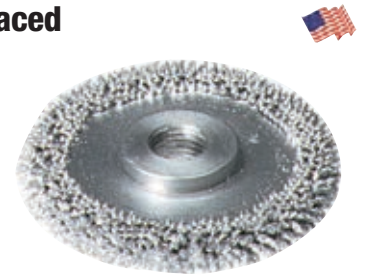

For skiving and texturing of large exterior section repairs. 3/8" x 24 Standard thread arbor hole.

Order No.	Mfr. No.	Diameter		Width		SSG
		In.	mm	In.	mm	
OL1300	300	2"	51.8	¼"	6.3	230
42776	302	2"	51.8	¼"	6.3	390
OL1304	304	2"	51.8	¾"	9.5	230
OL1306	306	2"	51.8	¾"	9.5	390
OL1308	308	2"	51.8	½"	12.7	230
OL1310	310	2"	51.8	½"	12.7	390
OL1312	312	2"	51.8	¾"	19	230
OL1314	314	2"	51.8	¾"	19	390

RUBBERHOG Nailhole Reamers

For plug repairs on fabric tires only.



Order No.	Mfr. No.	Diameter		Length		Shank	SSG
		In.	mm	In.	mm		
42762	626	¼"	6	3"	76	¼"	230

RUBBERHOG Taper

For small section repairs of tread and sidewall.



Order No.	Mfr. No.	Diameter		Length		Shank	SSG
		In.	mm	In.	mm		
42763	611	¾"	16	1"	25	¼"	330
OL1613	613	7/8"	22.2	1 ¼"	31.7	¼"	330

RUBBERHOG Rotor Saw

For small buzzout repairs of tread and sidewall.



Order No.	Mfr. No.	Diameter		Length		Shank	SSG
		In.	mm	In.	mm		
42777	619	1 ¾"	35	1 ¼"	32	¼"	330

RUBBERHOG Balls

For skiving and texturing of small exterior section repairs.



Order No.	Mfr. No.	Diameter		Shank	SSG
		In.	mm		
42767	601	¾"	16	¼"	330
42764	603	7/8"	22	¼"	330
42741	605	1 ½"	28.5	¼"	330

RUBBERHOG Black Contour Cup

For innerliner buffing. Standard tungsten carbide.



Order No.	Mfr. No.	Diameter		Width		Arbor Hole	Grit
		In.	mm	In.	mm		
42770	130-B	2"	51	¾"	19	¾"	60

MYERS Dualife Tungsten Carbide Rasps



- Two to three times the life of conventional tungsten carbide rasps
- Improved durability for longer lasting cutting
- Sharper carbide means cooler buffing & less chance for burning the buffed area

Solid Curved Cup Rasps

3/8", 1/2" and 5/8" Arbor Holes (Specify)

Order No.	Mfr. No.	Diameter		Width		Arbor Hole	Grit*
		In.	mm	In.	mm		
38211A1	K375	4"	102	1 1/2"	38	3/8"	16
38213A4	K376	4"	102	1 1/2"	38	3/8"	46

* Other grit available upon request.



38213A4

Vented Curved Cup Rasps

3/8", 1/2" and 5/8" Arbor Holes (Specify)

Order No.	Mfr. No.	Diameter		Width		Arbor Hole	Grit*
		In.	mm	In.	mm		
38416A1	TCW-315	3"	76	1 1/2"	38	3/8"	16
38417A3	TCW-3114	3"	76	1 1/4"	32	3/8"	36

* Other grit available upon request.



Non-Vented Radius Cup Rasps

3/8" x 24 Standard thread A.H.

Solid with heavy-duty machined core

Order No.	Mfr. No.	Diameter		Width		Arbor Hole	Grit*
		In.	mm	In.	mm		
38210	K360	3"	76	1"	25	3/8"	46

* Other grit available upon request.



Vented Radius Cup Rasps

Order No.	Mfr. No.	Diameter		Width		Arbor Hole	Grit*
		In.	mm	In.	mm		
38426A3		3"	76	1"	25	3/8"	36

* Other grit available upon request.



Vented Contour Cup Rasps

Vented
3/8" x 24 Standard thread arbor hole

Order No.	Diameter		Length		Grit*
	In.	mm	In.	mm	
38185	2"	51	1"	25	16
38186	2"	51	1"	25	36

* Other grit available upon request.



38186

MYERS Dualife Cone Rasps



38690

38235

3/8" x 24 Standard Thread

Order No.	Mfr. No.	Base Diameter		Length		Grit*
		In.	mm	In.	mm	
38690		3/4"	19	2"	51	36
38235	K331	3/4"	19	4"	102	16

* Other grit available upon request.

Specify Arbor Hole & Grit

Some of the above Dualife tungsten carbide rasps may be ordered in varying arbor holes and grit specifications.

Specify arbor hole size by adding the proper letter after the 5 digit Myers Order Number. Specify the grit by adding the proper number after the arbor hole letter.

Arbor Hole	Grit
A = 3/8" AH	1 = 16 Grit
B = 1/2" AH	2 = 24 Grit
C = 5/8" AH	3 = 36 Grit
	4 = 46 Grit
	6 = 60 Grit

For example 38211C3 is a 4" diameter; 5/8" arbor hole; 36 grit Cup Curved Rasp.

MYERS Dualife Tungsten Carbide Rasps



Flat Faced & Radius Faced



Air-Cooled and Ventilated 3/8" x 24 Standard Thread

Order No.	Mfr. No.	Diameter		Width		Grit*
		In.	mm	In.	mm	
38480	22-03	2"	51	3/16"	5	36
38481	22-04	2"	51	3/16"	5	16
38482	22-05	2"	51	3/8"	10	36
38483	22-06	2"	51	3/8"	10	16
Radius Faced						
38484	22-07	2"	51	1/2"	13	36
38485	22-08	2"	51	1/2"	13	16
38486	22-09	2"	51	3/4"	10	36
38487	22-10	2"	51	3/4"	10	16
Radius Rasp - Solid, Not Ventilated						
38202	K352	2"	51	3/8"	10	36

MYERS Dualife Rods

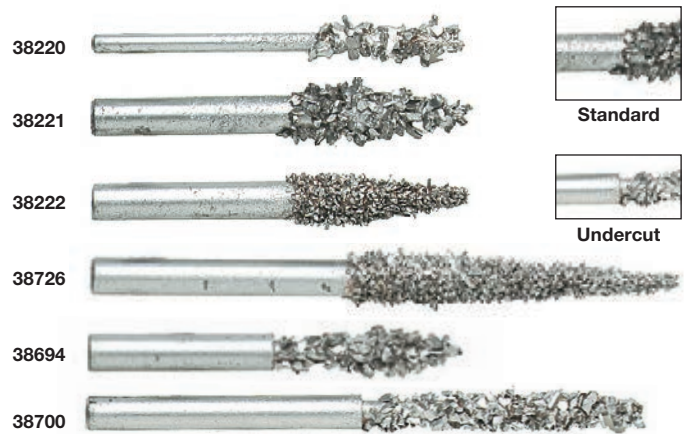

Standard

Undercut

Order No.	Mfr. No.	Diameter		Width		Grit*
		In.	mm	In.	mm	
Standard						
38220	K344	1/8"	3	2 1/4"	57	16
38221	K343	1/4"	6	2 1/4"	57	16
38222	K343A	1/4"	6	2 1/4"	57	36
38726		1/4"	6	4"	102	36
Undercut for 1/4" Cutting Accuracy (1/4" Outside Diameter)						
38694		1/4"	6	2 1/2"	64	16
38700		1/4"	6	4"	102	16

MYERS Regritting Available

Don't discard your old tungsten carbide rasps. New tungsten carbide grit bonded to your old worn rasps gives them a "new" rasping surface. Specify grit. To order Regrits - place "R" in front of suffix. Example: 38211RA3 is a regrit. (K-375) with a 3/8 AH 36 grit. Contact your Myers salesperson for details.

MYERS Lightweight Tube & Innerliner Cup Rasps

- 3/8" arbor hole

Order No.	Diameter		Width		Grit
	In.	mm	In.	mm	
42489	2 1/2"	64	3/8"	16	36
31604	2"	51	1/2"	13	36

* Other grit available upon request.



42489

MYERS Vented Radius Cup Rasps

- 3/8" arbor hole

Order No.	Diameter		Width		Grit
	In.	mm	In.	mm	
42426A3	3"	76.2	1"	25	36



MYERS Non-Vented Curved Cup Rasps

- 3/8" arbor hole

Order No.	Mfr. No.	Diameter		Width		Arbor Hole	Grit
		In.	mm	In.	mm		
42211A1	K-375	4"	101.6	1 1/2"	38.1	3/8"	16
42213A4	K-376	4"	101.6	1 1/2"	38.1	3/8"	46

42211A1



MYERS Non-Vented Radius Cup Rasps

42210 machine core 3/8" x 24 SAE thread arbor hole

Order No.	Mfr. No.	Diameter		Width		Grit
		In.	mm	In.	mm	
42210	K-360	3"	76.2	1"	25.4	46



MYERS Contour Cup Rasps

Air-Cooled and ventilated or non-ventilated. Arbor hole 3/8"-24 SAE standard thread.

Order No.	In.	Diameter mm	Width		Grit
			In.	mm	
42185	2"	51	1"	25	16 Vented
42186	2"	51	1"	25	36 Vented
42187	2"	51	1"	25	60 Vented
42190	2"	51	1"	25	16 Solid
42191	2"	51	1"	25	36 Solid
42189	2"	51	1"	25	60 Solid



Vented



Solid

MYERS Vented Flat Wheel Rasps



42440



42453

Other grit sizes and arbor holes available upon request.

Order No.	Mfr. No.	Diameter		Width		Arbor Hole	Grit
		In.	mm	In.	mm		
42440	TFW-310	3"	76	1"	25	*	Specify
42452	TFW-610	5"	152	1"	25	**	Specify
42453	TFW-615	6"	152	1 1/2"	38	**	Specify

* Specify arbor hole size 3/8" to 3/4" ** Specify arbor hole size 1/2" to 3/4"

MYERS Vented Curved Cup Rasps



42417A3



42419B3



42292

Arbor Hole 3/8" 1/2" 3/4" specify. Other grit sizes and arbor holes available upon request.

Order No.	Mfr. No.	Diameter		Width		Arbor Hole	Grit
		In.	mm	In.	mm		
42414A1	TCW-310	3"	76	1"	25	3/8"	16
42414A3	TCW-310	3"	76	1"	25	3/8"	36
42417A3	TCW-3114	3"	76	1 1/4"	32	3/8"	36
42473A1	TCW-3114	3"	76	1 1/4"	32	3/8"	16
42416A1	TCW-315	3"	76	1 1/2"	38	3/8"	16
42416A2	TCW-315	3"	76	1 1/2"	38	3/8"	24
42416A3	TCW-315	3"	76	1 1/2"	38	3/8"	36
42416A4	TCW-315	3"	76	1 1/2"	38	3/8"	46
42416A6	TCW-315	3"	76	1 1/2"	38	3/8"	60
42431A1	TCW-415	4"	102	1 1/2"	38	3/8"	16
42419A3	TCW-415	4"	102	1 1/2"	38	3/8"	36
42431B1	TCW-415	4"	102	1 1/2"	38	1/2"	16
42419B3	TCW-415	4"	102	1 1/2"	38	1/2"	36
42491	TCW-515	5"	127	1 1/2"	38	7/8"	36
42291	TCW-515	5"	127	1 1/2"	38	1/2"	23
42292	TCW-615	6"	152	1 1/2"	38	*	36
42293	TCW-615	6"	152	1 1/2"	38	*	16

* Specify arbor hole size 1/2" to 3/4"

MYERS Vented Donut Curved Rasps



42427A3



42405



42211A1

Arbor Hole 3/8" 1/2" 3/4" specify. Other grit sizes and arbor holes available upon request.

Order No.	Mfr. No.	Diameter		Width		Arbor Hole	Grit
		In.	mm	In.	mm		
42400A1	TDW-310	3"	76	1"	25	3/8"	16
42427A3	TDW-310	3"	76	1"	25	3/8"	36
42401A1	TDW-315	3"	76	1 1/2"	38	3/8"	16
42428A3	TDW-315	3"	76	1 1/2"	38	3/8"	36
42402A1	TDW-410	4"	102	1"	25	3/8"	16
42429A3	TDW-410	4"	102	1"	25	3/8"	36
42403A1	TDW-415	4"	102	1 1/2"	38	3/8"	16
42403B1	TDW-415	4"	102	1 1/2"	38	1/2"	16
42405	TDW-510	5"	127	1"	25	*	Specify
42407	TDW-515	5"	127	1 1/2"	38	*	Specify
42493	TDW-5118	5"	127	1 1/2"	28	*	Specify
42410	TDW-615	6"	152	1 1/2"	38	**	Specify

* Specify arbor hole size 3/8" to 3/4" ** Specify arbor hole size 1/2" to 3/4"

Note: We Recommend

Use 36 grit and up for rubber finishing & cleaning
Use 16 grit for buffing, skiving, & cutting.

Tungsten Carbide Rasps

MYERS 2" Rasps

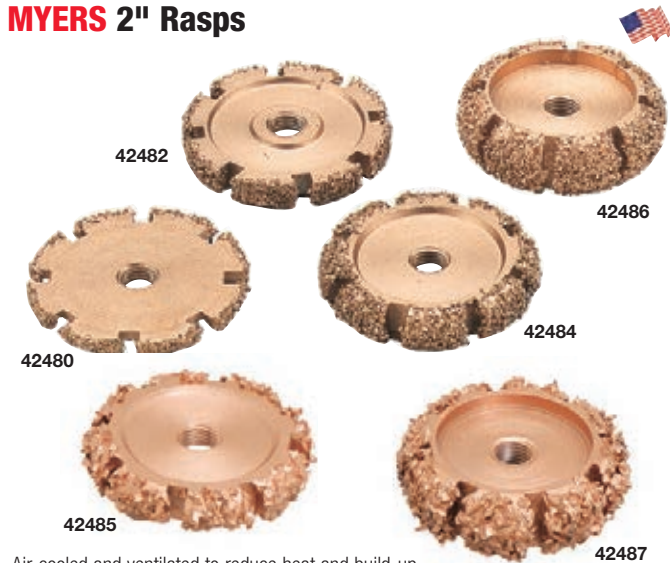

Air-cooled and ventilated to reduce heat and build-up.

Arbor Hole 3/8" – 24 SAE thread

Order No.	Mfr. No.	Diameter		Width		Grit
		In.	mm	In.	mm	
Flat Faced						
42480	22-03	2"	50.8	3/16"	4.7	36
42481	22-04	2"	50.8	3/16"	4.7	16
42482	22-05	2"	50.8	3/8"	9.5	36
42483	22-06	2"	50.8	3/8"	9.5	16
Radiused						
42484	22-07	2"	50.8	1/2"	12.7	36
42485	22-08	2"	50.8	1/2"	12.7	16
42486	22-09	2"	50.8	3/4"	19	36
42487	22-10	2"	50.8	3/4"	19	16

MYERS 4" & 6" Flat Face Rasps



Air-cooled and ventilated to reduce heat and build-up. Arbor hole 1/2"-24 SAE thread. Specify grit

Order No.	Mfr. No.	Diameter		Width		Grit
		In.	mm	In.	mm	
42443	T414	4"	102	1/4"	19	Specify
42444	T438	4"	102	3/8"	10	Specify
42445	T450	4"	102	1/2"	12.7	Specify
42446	T458	4"	102	3/8"	16	Specify
42447	T475	4"	102	3/4"	19	Specify
42448	T410	4"	102	1"	25.4	Specify
42717	UC650	6"	152.4	1/2"	12.7	16 Grit
42718	UC610	6"	152.4	1"	25.4	Specify

Regritting Available

Don't discard your old tungsten carbide rasps. New tungsten carbide grit bonded to your old worn rasps gives them a "new" rasping surface. Specify grit. To order Regrits – place "R" in front of suffix. Example: 38211RA3 is a regrit. (K-375) with a 3/8 AH 36 grit. Contact your Myers salesperson for details.

MYERS 1-1/2" Mini-Rasps



Reduce overbuff and spend less time buffing, filling and finishing an injury. Air-cooled and ventilated to reduce heat and build-up. Arbor hole 3/8"-24 SAE thread. Special grits available (Specify).

Order No.	Diameter		Width		Grit
	In.	mm	In.	mm	
Flat Faced					
42698	1 1/2"	38	1/8"	3	38
42699	1 1/2"	38	1/8"	3	36
42551	1 1/2"	38	3/16"	5	16
42553	1 1/2"	38	3/16"	5	36
42692	1 1/2"	38	1/2"	13	16
42693	1 1/2"	38	1/2"	13	36
Radiused					
42554	1 1/2"	38	5/8"	10	16
42556	1 1/2"	38	5/8"	10	36

MYERS Mega-Wheels

Fast buffing, long-lasting Dualife super grit

- Air cooled & ventilated to reduce heat
- Other grit & arbor hole sizes available on request
- All units regrittable with option to exchange same size with other grit & arbor hole sizes



Order Number	Mfr. No.	Diameter		Width		Arbor Hole	Grit
		in	mm	in	mm		
Flat Faced							
43280	33-03FFAC	3"	76	1/4"	4.8	3/8"SAE	36
43281	33-04FFAC	3"	76	1/4"	4.8	3/8"SAE	16
43282	33-05FFAC	3"	76	3/8"	9.5	3/8"SAE	36
43283	33-06FFAC	3"	76	3/8"	9.5	3/8"SAE	16
43288	44-03FFAC	4"	102	1/4"	4.8	3/8"SAE	36
43289	44-04FFAC	4"	102	1/4"	4.8	3/8"SAE	16
43290	44-05FFAC	4"	102	3/8"	9.5	3/8"SAE	36
43291	44-06FFAC	4"	102	3/8"	9.5	3/8"SAE	16
43294	66-03FFAC	6"	152	1/4"	4.8	3/8"SAE	36
43295	66-04FFAC	6"	152	1/4"	4.8	3/8"SAE	16
43296	66-05FFAC	6"	152	3/8"	9.5	1/2" AH	36
43297	66-06FFAC	6"	152	3/8"	9.5	1/2" AH	16
Round Face							
43284	33-07RFAC	3"	76	1/2"	12.7	3/8"SAE	36
43285	33-08RFAC	3"	76	1/2"	12.7	3/8"SAE	16
43286	33-09RFAC	3"	76	3/4"	9.5	3/8"SAE	36
43287	33-10RFAC	3"	76	3/4"	9.5	3/8"SAE	16
43292	44-07RFAC	4"	102	1/2"	12.7	3/8"SAE	36
43293	44-08RFAC	4"	102	1/2"	12.7	3/8"SAE	16
43298	66-07RFAC	6"	152	1/2"	12.7	1/2" AH	36
43299	66-08RFAC	6"	152	1/2"	12.7	1/2" AH	16

MYERS Air Cooled Buffing & Finishing Wheels



Available in 3" to 8" diameter, any width, 36 grit to 240 grit. Arbor hole 1/2, 3/8, and 3/4 std. When ordering specify diameter, width, arbor hole and grit.



Order No.	Diameter		Width	
	In.	mm	In.	mm
42705	3"	76	3/4"	6
42706	3"	76	3/8"	10
42707	3"	76	1/2"	13
42708	3"	76	3/4"	19
42709	3"	76	1"	25
42710	4"	102	3/8"	10
42711	4"	102	1/2"	13
42712	4"	102	3/8"	16
42713	4"	102	3/4"	19
42714	4"	102	1"	25

Order No.	Diameter		Width	
	In.	mm	In.	mm
42715	4"	102	1 1/2"	38
42716	6"	152	3/8"	10
42717	6"	152	1/2"	13
42718	6"	152	1"	25
42719	6"	152	1 1/2"	38
42720	8"	203	1/2"	13
42721	8"	203	3/8"	16
42722	8"	203	3/4"	19
42723	8"	203	1"	25
42724	8"	203	1 1/2"	38

MYERS Cone Rasps



Arbor Hole 3/8-24 SAE thread.

Order No.	Mfr. No.	Base Diameter		Length		Grit
		In.	mm	In.	mm	
42690		3/4"	19	2"	51	36
42691		3/4"	19	2"	51	16
42234	K-332	3/4"	19	4"	102	36
42235	K-331	3/4"	19	4"	102	16
1 1/2" Bullnose Cone						
42253		3/4"	19	1 1/2"	38	36
42254		3/4"	19	1 1/2"	38	16

MYERS Rods



Standard Cut

Undercut

Order No.	Mfr. No.	Diameter		Width		Grit
		In.	mm	In.	mm	
42220	K-344	1/8"	3	2 3/4"	57	16
42221	K-343	1/4"	6	2 3/4"	57	16
42222	K-343A	1/4"	6	2 3/4"	57	36
Undercut for (1/4" Cutting Accuracy)						
42694		1/4"	6	2 1/2"	64	16
42695		1/4"	6	2 1/2"	64	36
42700		1/4"	6	4"	102	16
42701		1/4"	6	4"	102	36
Standard						
42725		1/4"	6	4"	102	16
42726		1/4"	6	4"	102	3

MYERS Flat Cup Rasps



Arbor hole 3/8"-24 SAE thread.

Order No.	Mfr. No.	Diameter		Width		Grit
		In.	mm	In.	mm	
42226	K-338	2"	51	1/2"	13	46
42227	K-337	2"	51	1/2"	13	16
42228	K-335	2"	51	1"	25	46
42229	K-334	2"	51	1"	25	16

MYERS Tapered Rasps



Arbor hole 3/8-24 SAE thread.

Order No.	Mfr. No.	Diameter		Width		Grit
		In.	mm	In.	mm	
42215	K-358	2"	51	1"	25	16
42216	K-359	2"	51	1"	25	36

42215

MYERS Ball Rasps



42696

Order No.	Shaft Length	Shaft Diameter		Ball diameter		Grit	
		In.	mm	In.	mm		
42696	2"	51	1/4"	6	3/4"	19	16
42697	2"	51	1/4"	6	3/4"	19	36

MYERS Wheel Rasps



Arbor Hole 3/8" - 24 SAE thread

Order No.	Mfr. No.	Diameter		Width		Grit*
		In.	mm	In.	mm	
42240	K-340	2 1/2"	64	3/8"	8	16

MYERS Angle Faced Rasps



3/4" (19mm) wide, 5/8" Arbor hole only



42490

Order No.	Diameter	Arbor Hole	Grit	
				In.
42490	4"	102	3/8"	23 Solid
42495	4"	102	3/8"	23 Ventilated

MYERS Flat Ventilated 7" Disc Rasps



Other grit sizes available upon request. Only 7/8" arbor hole available.

Order No.	Mfr. No.	Arbor Hole	Grit
42249	DSK-738	7/8"	16 Vented
42492	DSK-738	7/8"	24 Vented

Note: We Recommend

Use 36 grit and up for rubber finishing & cleaning
Use 16 grit for buffing, skiving, & cutting.

Tungsten Carbide Rasps

JENSEN Disposable Rasps

- Long-lasting, value-priced & designed to be disposable

JENSEN Flat-Faced Carbide Rasps



Arbor hole $\frac{3}{8}$ "-24 SAE thread.

Order No.	Mfr. No.	Diameter		Width		Grit
		In.	mm	In.	mm	
42303	21-098 (22-04)	2"	50.8	$\frac{3}{16}$ "	4.7	16
42302	21-098 (22-03)	2"	50.8	$\frac{3}{16}$ "	4.7	36
42301	21-099	2"	50.8	$\frac{1}{4}$ "	6.4	16
42300	21-099	2"	50.8	$\frac{1}{4}$ "	6.4	36
42304	21-100 (22-06)	2"	50.8	$\frac{3}{8}$ "	9.5	16
42305	21-101 (22-05)	2"	50.8	$\frac{3}{8}$ "	9.5	36

JENSEN Round-Faced Carbide Rasps



Arbor hole $\frac{3}{8}$ "-24 SAE thread.

Order No.	Mfr. No.	Diameter		Width		Grit
		In.	mm	In.	mm	
42306	21-102 (22-08)	2"	50.8	$\frac{1}{2}$ "	12.7	16
42307	21-103 (22-07)	2"	50.8	$\frac{1}{2}$ "	12.7	36
42308	21-104 (22-10)	2"	50.8	$\frac{3}{4}$ "	19	16
42309	21-105 (22-09)	2"	50.8	$\frac{3}{4}$ "	19	36
42310	21-106	2"	50.8	$\frac{7}{8}$ "	22.2	16
42311	21-107	2"	50.8	$\frac{7}{8}$ "	22.2	36

JENSEN Solid Contour Cup Rasps



Arbor hole $\frac{3}{8}$ "-24 SAE thread.

Order No.	Mfr. No.	Diameter		Width		Grit
		In.	mm	In.	mm	
42312	21-108	2"	50.8	1"	25.4	16
42313	21-109	2"	50.8	1"	25.4	36
42314	21-110	2"	50.8	1"	25.4	60

3" & 4" Vented Curved Cup Rasps



Order No.	Mfr. No.	Diameter		Width		Arbor Hole	Grit
		In.	mm	In.	mm		
42318	TCW310	3"	76.2	1"	25.4	$\frac{3}{8}$ "	16
42319	TCW310	3"	76.2	1"	25.4	$\frac{3}{8}$ "	36
42320	TCW310	3"	76.2	1"	25.4	$\frac{3}{8}$ "	60
42321	TCW315	3"	76.2	1 $\frac{1}{2}$ "	38.1	$\frac{3}{8}$ "	16
42322	TCW315	3"	76.2	1 $\frac{1}{2}$ "	38.1	$\frac{3}{8}$ "	36
42323	TCW315	3"	76.2	1 $\frac{1}{2}$ "	38.1	$\frac{3}{8}$ "	60
42315	TCW415	4"	101.6	1 $\frac{1}{2}$ "	38.1	$\frac{3}{8}$ "	16
42316	TCW415	4"	101.6	1 $\frac{1}{2}$ "	38.1	$\frac{3}{8}$ "	36
42317	TCW415	4"	101.6	1 $\frac{1}{2}$ "	38.1	$\frac{3}{8}$ "	60
42324	TCW415	4"	101.6	1 $\frac{1}{2}$ "	38.1	$\frac{1}{2}$ "	16
42325	TCW415	4"	101.6	1 $\frac{1}{2}$ "	38.1	$\frac{1}{2}$ "	36
42326	TCW415	4"	101.6	1 $\frac{1}{2}$ "	38.1	$\frac{1}{2}$ "	60

TEMCO Tungsten Carbide Abrasive Sleeves

- For finishing rubber, plastic, any non-metallic material



Tungsten carbide particles permanently bonded to steel sleeves.

3" (76.2mm) diameter x 1" (25.4mm) wide 3" (76.2mm) diameter x 2" (50.8mm) wide 3" (76.2mm) diameter x 3" (76.2mm) wide

Order No.	Mfr. No.	Grit	Order No.	Mfr. No.	Grit	Order No.	Mfr. No.	Grit
42125	TB-400	24	42127		24	42132		16
42122	TB-400A	36	42128	TB-402A	36	42133		24
42123	TB-400B	60	42129	TB-402B	60	42134	TB-401A	36
42124	TB-400C	120	42130	TB-402C	120	42135	TB-401B	60
						42136	TB-401C	120

TEMCO Sanding Drums for Abrasive Sleeves



True-running uniform expansion molded rubber drums. Includes arbor for attaching to flexible shafts, electric drills, drill presses, open end buffers, etc. Squeezing action of flanges expands drum to fit tightly against abrasive sleeves. Sleeves cannot slip.

Order No.	Mfr. No.	Arbor Hole	Size
3" (76.2 mm) Diameter x 1" (25.4 mm) wide			
42101	TB-140	$\frac{1}{16}$ "	18 SAE F
42102	TB-140A	$\frac{1}{2}$ "	20 SAE F
42103	TB-140B	$\frac{3}{8}$ "	16 USS F
42104	TB-140R		Repl. Rubber
3" (76.2 mm) Diameter x 2" (50.8 mm) wide			
42107	TB-340	$\frac{1}{16}$ "	18 SAE F
42108	TB-340A	$\frac{1}{2}$ "	20 SAE F
42109	TB-340B	$\frac{3}{8}$ "	16 USS F
42110	TB-340R		Repl. Rubber
3" (76.2 mm) Diameter x 3" (76.2 mm) wide			
42113	TB-540	$\frac{1}{16}$ "	18 SAE F
42114	TB-540A	$\frac{1}{2}$ "	20 SAE F
42115	TB-540B	$\frac{3}{8}$ "	16 USS F
42116	TB-540R		Repl. Rubber

Buffing Stone

2" diameter (50.8 mm) x 1 $\frac{1}{4}$ " (44.5 mm) face, fits any low speed buffer or electric drill. $\frac{1}{4}$ " Shaft, 24 grit. 42498 Adapter required to use with a quick change chuck



Order No.	Mfr. No.	Description	Maximum RPM
42642	A-600-A	Buffing Stone	7,000
42498	TB-3BH	$\frac{1}{4}$ " Shaft Adapter w/Set Screw	

Contour Buffing Stone

For use with a low speed buffer. 4" (102mm) diameter x 1 $\frac{1}{2}$ " (38.1mm) face. Used for buffing tire injuries. Made of bonded silicone carbide. Beveled, medium hard, 24 grit.



Order No.	Mfr. No.	Arbor Hole	Maximum RPM
42644	5946	$\frac{1}{2}$ "	4,200

B&J Squiggly Rasps

- Fast rubber removal
- Less heat & scorching

For use on hand held buffers for buzzouts and rubber removal jobs. 45° Angle cutting surface creates the squiggly effect. Two specially formed steel plates hold it in place. 2" diameter with 3/8" arbor hole.



Order No.	Mfr. No.	Description
43513	20-103	10 Pack with 2 Plates
43514	20-104	24 Pack with 2 Plates
43515		Replacement Plates - Set of 2
42399		Quick Change Adaptor with Spacer

B&J 5" Buffing Rasp

- Use for OTR repairs
- 5" Diameter

For hand-held buffers and grinders. Contact us for special applications.



Order No.	Mfr. No.	Description	Arbor Hole
43519	12003	R2 Regular Rasp Hub 2" Wide	1/2"
43520	12003-3	R2 Regular Rasp Hub 1-1/2" Wide	1/2"

Tack Rasps & Hubs for Flex Shafts & Drills

Small tack bands for buffing or grinding. Fits over small hubs for use on drills and flex shafts. Hub unit includes an expansion ring.



Order No.	Mfr. No.	Diameter		Width		A.H.	For Hub
		In.	mm	In.	mm		
43271	6	2 1/2"	64	1"	25		B-6
43273	8	1 1/2"	38	5/8"	16		B-8
43263A	B-6	2 1/2"	64	1"	25	3/8"	
43263B	B-6	2 1/2"	64	1"	25	1/2"	
43265A	B-8	1 1/2"	38	5/8"	16	3/8"	

R-5 & R-6 Rasps

For drills and flexible shafts buffers. Adapters to fit all sizes of female and male couplings are available. 1/2" Arbor only.

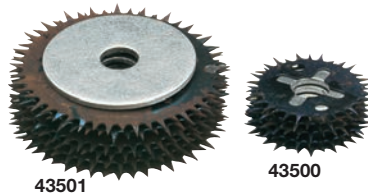

Order No.	Mfr. No.	Description	Arbor Hole
43500	R-5 Rasps w/ Spacers	1 3/4" Dia. x 1/2" w	1/2"
43501	R-6 Rasps w/ Spacers	3" Dia. x 3/8" w	1/2"
43502	R-5-R	Refills, 5 Per Set	
43504	R-6-R	Refills, 6 Per Set	

7" Tac-A-Disc

Hardened tacks mounted in a 7" diameter concave disc. 7/8" Arbor hole.



Order No.	Mfr. No.	Description	Arbor Hole
42267	7-C	Tac-A-Disc "C"	7/8"

Piranha Carbide Rasps

Ideal durable carbide rasp for removing large amounts of rubber. Stackable, just add washers between them and use a wider width carbide for big jobs. Not regritable. Use the 42399 adapter with the spacer for a single Piranha.



Order No.	Mfr. No.	Description	Grit	Diameter	Width
42193	208-16	Piranha Rasp	16	2"	1/2"
42194	208-36	Piranha Rasp	36	2"	1/2"
42399		Quick Change Adapter with Spacer			

B&J Rotary Gougers

- Removes rubber fast & easy



The lightweight, low profile design gives improved control. Available in notched or un-notched styles. Thin wall sizes to fit all requirements. Notched gouger for use on fabric tires, un-notched on wire fabric. Sold in box quantity only.

Order No.	Mfr. No.	Diameter		Arbor	Notches	Per Box
		In.	mm			
31088	11-607	3/4"	19	3/8"	No	4
31083	11-604	1 1/4"	32	3/8"	No	3
31081A	11-610	2"	51	3/8"	No	2
31081B	11-610-1	2"	51	1/2"	No	2
31082A	11-612	2"	51	3/8"	Yes	2
31082B	11-612-1	2"	51	1/2"	Yes	2
Heavy-Duty Rotary Gouger						
31079	11-606	2"	51	1/2"	Yes	1
31092	11-605	2"	51	1/2"	No	1
Adapters						
31086	17-200	1/2" To 3/8" Reducer Bushing				
42421	TB-04A	3/8"-24 Thread Adapter				

B&J Threaded Rotary Gougers

3/8"-24 thread to be screwed onto an adapter. Use the nut supplied with the optional 42421 Adapter to keep the gouger toward the top of the threads.



Order No.	Mfr. No.	Diameter		Arbor	Notches	Per Box
		In.	mm			
31088	11-607	3/4"	19	3/8"-24 Thread	No	4
31087	11-603	1 1/4"	32	3/8"-24 Thread	No	3
31095	11-610-2	2"	51	3/8"-24 Thread	No	2
31096	11-612-2	2"	51	3/8"-24 Thread	Yes	2
42421	TB-04A	3/8"-24 Thread Adapter				

B&J Rotary Gouger Sharpeners

Sharpen small or large rotary gougers. Press the spinning gouger between the angled stones. Replacement stones available.



Order No.	Mfr. No.	Description	Per Box
31089	11-626	Sharpener for 3/4" to 1 1/4"	
31090	11-636	Replacement Stone for 3/4" to 1 1/4"	2 Per Box
31084	11-625	Sharpener for 1 1/4" to 2"	
31085	11-635	Replacement Stone for 1 1/4" to 2"	6 Per Box

Tire Repair Brushes

Texturing Brushes

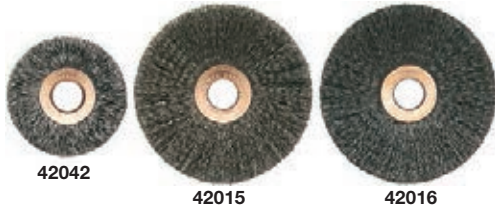

Wire brushes for texturing rubber surfaces and tire innerliners. For use in low speed grinders. Removable plastic insert for 1/2" arbor hole.

Order No.	Diameter		Width		Wire	Arbor Hole	
	In.	mm	In.	mm		In.	mm
42042	2"	50.8	1/4"	6	.0118	3/8"	10
42015	3"	76.2	1/4"	6	.008 Coarse	3/8"	10
42016	3"	76.2	1/4"	6	.006 Fine	3/8"	10

* Remove plastic insert for 1/2" arbor hole

Plastic Encapsulated Brushes

Minimizes bristle spreading, controls cut depth and bristle wear. Removable plastic insert for 1/2" arbor hole.

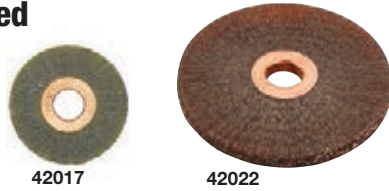

Order No.	Diameter		Width		Wire	Arbor Hole	
	In.	mm	In.	mm		In.	mm
42017	2"	50.8	1/4"	6	.006 Fine	3/8"	10
42022	3"	76.2	1/4"	6	.008	3/8"	10

* Remove plastic insert for 1/2" arbor hole

Rubber Encapsulated Wire Brushes

.006 wire., 1/4" face width

Order No.	Mfr. No.	Arbor Hole	
		In.	mm
42162	S897	3/8"	10
42163	S893	3/8"	10



3" Tire Buffing Brush



Excellent for use in preparing buzz-outs. .0118 Wire.

Order No.	Mfr. No.	Diameter		Width		Arbor Hole	
		In.	mm	In.	mm	In.	mm
31601	5231	3"	76	1/4"	6	3/8"	10

3" Skiving Brush & Double Adapter

- Standard or encapsulated brushes
- Encapsulated brush lasts longer

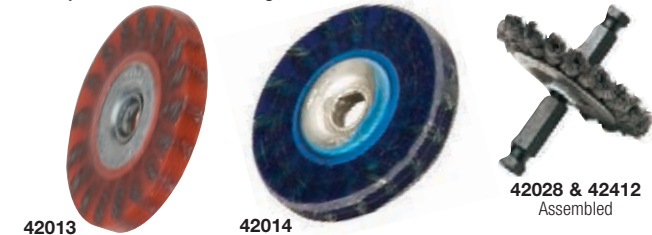

Used for buzz outs to skive injured area after buffing. The stiff brush is designed to cut, not texture. The encapsulated brush wears more evenly and lasts longer. The double adapter allows the operator to reverse the sharp side of the brush without having to remove the nut and washer. Removable plastic insert for 1/2" arbor hole.

Order No.	Description	Arbor Hole	
		In.	mm
42028	76964 Brush	3/8"	10
42014	Wide Encapsulated Brush	3/8"	10
42013	Narrow Encapsulated Brush	3/8"	10
42412	Double Adapter		

4" Inner Tube Buffing Brush



Extra soft wire for buffing inner tubes. Fits bench grinder or flexible shaft buffer. .004 wire. 4" diameter, 1/2" arbor hole.

Order No.	Mfr. No.
42038	0B-24

4" Tire Sidewall Brush



For preparing casings after surplus rubber is removed, and before camelback is applied. .0118 wire. 4" dia. x 1" width, 1/2" arbor hole.

Order No.	Mfr. No.
42024	1419

4" Twisted Wire Brush



For roughening and removing excess rubber. .020 Twisted wire. Removable plastic insert for 1/2" Arbor hole.

Order No.	Mfr. No.	Diameter		Width		Arbor Hole	
		In.	mm	In.	mm	In.	mm
42030	7810	4"	102	3/8"	10	3/8"	10

* Remove plastic insert 1/2" arbor hole

4" Twisted Wire Brush



For roughening and removing excess rubber. 5/8"-11 Threaded nut arbor hole.

Order No.	Mfr. No.	Diameter		Width	
		In.	mm	In.	mm
42009	5516-5	4"	102	3/8"	10

6" Twisted Wire Rim Buffing Brush



Approved by major rubber companies. Operates off flexible shaft buffers, bench grinders, or drill with speeds of 3,450 rpm or faster. .014 wire. For best results use 2 brushes side by side.

Order No.	Mfr. No.	Diameter		Width		Arbor Hole	
		In.	mm	In.	mm	In.	mm
42082	7814	6"	152	1/2"	13	1/2"	13

* Remove plastic insert 1/2" arbor hole

6" Rim Buffing Brush



Operates off flexible shaft buffers, bench grinders, or drill with speeds of 3,450 RPM or faster. .016 wire with 3/8"-11 threaded nut arbor hole.

Order No.	Diameter		Width	
	In.	mm	In.	mm
84009	6"	152	1/2"	13

Brass Sidewall Buffing Brushes



Replacement brush for the sidewall buffing attachment. 6" diameter brass brush, 1 3/4" wide.

Order No.	Description	Arbor Hole
42025	6" Brass Sidewall Brush	3"

Sidewall Buffing Brush For Bandag 8400 Series Buffers



For 8400 Series buffing attachment. 1 1/2" wide x 8" with a 2" arbor hole.

Order No.	Description
42035	8" Sidewall Brush

Wire Wheel Brushes



Patented carbon steel wire will not break off, separate, or heat up and scorch rubber or cord. All .010 wire. Brushes have 2 1/4" arbor hole and include 1/2" or 3/4" bushings except where noted.

Order No.	Mfr. No.	Diameter In.	Diameter mm	Arbor	Face Width	Description
42001B	412	4"	102	1/2"	1"	
42002B	432	4 1/4"	108	1/2"	1"	
42002D*	432	4 1/4"	108	3/4"	1"	For Use on Bandag sidewall buffers
42003B	632	6"	152	1/2"	1"	
42003M21***	632	6"	152	21mm	1"	For Use on Matteuzzi RAS 90 & 98E Ultra
42003M38***	632	6"	152	38mm	1"	For Use on Matteuzzi RAS 98E
42004C	832	8"	203	5/8"	1"	
42006J	1035	10"	254	2"	2 1/2"	

Steel Wheel Brush

- 5/8"-11 Threaded Nut
- Adapters available to reduce to 3/8"-24 thread. Contact us.



Use for cleaning rust and debris from passenger and truck steel wheels. 4" diameter, 5/8" 11 threaded arbor hole, 9,000 max. rpm.

Order No.	Mfr. No.	Description
42010	7076	Steel Wheel Brush

Stem Brushes



Use for preparing tire injury after drilling or grinding. Solid shaft will not unravel during use. Use with low speed tool.

Order No.	Description
42161	3/8" Stem Brush
42117	1/2" Stem Brush
42119	3/4" Stem Brush

Quick Change Chuck & Adapters



Use any of the adapters listed with the 42415 chuck.

Order No.	Mfr. No.	Description
42415	TB-20C	Quick Change Chuck (3/8" - 24 FPT)
42424	MQC-2-13	Quick Change Chuck (1/2" - 13 FPT)
42365		3/16" - 18 Quick Change Chuck (3/16" - 18 FPT)
42420	TB-4	3/8" - 24 Adapter, 2 1/4" Long
42421	TB-4A	3/8" - 24 Adapter 1" Long Thread, 2 1/4" Length with 2 Washers, Nut for Mounting Tools with 3/8" Arbor Hole
42422	TB-4S	3/8" - 24 Short Adapter 1 7/8" Long
42497	TB-3AH	1/8" Shaft Adapter with Set Screw
42498	TB-3BH	1/4" Shaft Adapter with Set Screw
42375	2540	3/16" 3 Tang Shank Adapter with set screw
42376	2541	5/16" 3 Tang Shank Adapter with set screw
42370	CC	7/16" And 3/8" Shank Adapter with set screw
42399	TB-4B	Quick Change Adapter with Spacer
42412		Double Adapter for Skiving Brush
42425L		1/2" Double Quick Change Adapter with Nut
49635		5/32" x 3/16" Set Screws for 42497, 42498, 42375, 42376 Adapters. 25 Per Bag

Jacobs Chucks & Adapters



Order No.	Mfr. No.	Description
31699	30247	3/8" Chuck & Key (3/8"-24 Thread)
42039	TB-310-D	1/4" Shank to 1/2" SAE Male
42041	TB-320-D	1/4" Shank to 3/8" USS Male
42246	K-345	For 1/4" Drill to 3/8" USS Male

White Sidewall Buffing Stone



Vitrified white sidewall buffing wheel. Maximum operating speed 4,200 RPM.

Order No.	Grit	Diameter		Width		Arbor Hole	
		In.	mm	In.	mm	In.	mm
42656	46	4"	102	1 1/2"	38	1/2"	13

LINCOLN ERV Envelope Repair Spotter

Features a large 6" curing head with an air-driven silicone rubber piston pad providing even pressure during the cure cycle. Built-in timer turns off heat and air automatically. Throat depth 14½". Includes bench mount brackets. 220V Model available. See page 63 for #14340 Envelope Repair Kit.



Order No.	Description	Ship Wt.
36464	ERV Vulcanizer (110V)	60 lbs. - 27 kg.

LINCOLN 150 Heavy-Duty Electric Tube Plate Spotter

- 12" x 4-3/8" Curing surface

For large repairs on all sizes of inner tubes. Detachable plate for vulcanizing valve stems. Thermostatically controlled, high wattage element reaches curing temperature fast.



Order No.	Mfr. No.	Description	Ship Wt.
36500	150	Heavy-Duty Tube Plate Vulcanizer 120V	40 lbs. - 18 kg.
36392	150	Heavy-Duty Tube Plate Vulcanizer 240V	40 lbs. - 18 kg.
36507	T075	Truck Valve Stem Adapter	1 lbs. - 1 kg.
36510	T076	3¾" Base Air/Water Tractor Valve Stem Adapter	1 lbs. - 1 kg.
36509	T035	Replacement Heat Unit 120V	6 lbs. - 3 kg.
36518	T035	Replacement Heat Unit 240V	6 lbs. - 3 kg.

LINCOLN 200 Electric Tube Plate Spotter

- 4-3/8" x 6-3/8" Curing surface

Quick heating, snap type thermostat reaches and maintains curing temperature fast. Detachable flat plate for curing valve stems. Trigger action clamp for quick work adjustments.



Order No.	Mfr. No.	Description	Ship Wt.
36506	200	Tube Plate Vulcanizer 120V	27 lbs. - 13 kg.
36394	200	Tube Plate Vulcanizer 240V	27 lbs. - 13 kg.
36507	T075	Truck Valve Stem Adapter	1 lbs. - 1 kg.
36510	T076	3¾" Base Air/Water Tractor Valve Stem Adapter	1 lbs. - 1 kg.
36508	T036	Replacement Heat Unit 120V	4 lbs. - 2 kg.
36516	T036	Replacement Heat Unit 240V	4 lbs. - 2 kg.

LINCOLN 3100PL Portable Electric Truck Bead Spotter

- Application: truck tire bead repairs
- Maximum injury size 7"

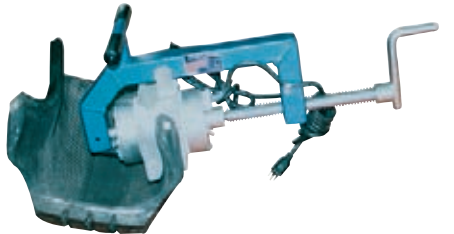

Clamp-on the lightweight and portable vulcanizer, tighten the screw and it's ready to repair bead injuries up to 7". Features inside and outside heat units for fast, controlled curing; bead plates for 11:22.5 and 11:24.5 truck tires are included.

Order No.	Mfr. No.	Description	Ship Wt.
36315	3100PL	Bead Vulcanizer 120V	38 lbs. - 17 kg.
36316	3100PL	Bead Vulcanizer 240V	38 lbs. - 17 kg.
36268	T047	Replacement Outside Heat Unit 120V	
36267	T048	Replacement Inside Heat Unit 120V	

LINCOLN 300 Passenger Tire Spotter

- Throat depth 4"
- Throat height 8-1/4"
- 3-5/16" Curing surface
- Spotter plates see page 88



Thermostatically controlled heat unit reaches operating temperature quickly for fast cure rates. Unit can be bench mounted or used as a portable vulcanizer. Optional 36273 Plate package includes three 4" plates.

Order No.	Mfr. No.	Description	Ship Wt.
36400	300	Vulcanizer 120V without Plates	12 lbs. - 5 kg.
36281	300	Vulcanizer 240V without Plates	44 lbs. - 20 kg.
36273	T149	Optional Plate Pkg. for 300	2 lbs. - 1 kg.
36404	T038	Replacement Heat Unit 120V	2 lbs. - 1 kg.
36399	T038	Replacement Heat Unit 240V	2 lbs. - 1 kg.

LINCOLN LT Air/Electric Light Truck Tire Spotter

- Throat depth 8-¼" (21 cm)
- Throat height 19" (48 cm)
- Maximum injury size 3-½"
- Spotter plates see page 88



Shown with Optional Stand

Application: tread, shoulder, & sidewall repairs

Repair the tread, shoulder, and sidewall areas of passenger and light truck tires with one vulcanizer. Piston pad air head produces professional looking sidewall repairs. Tread and shoulder areas are solidly repaired with constant pressure provided by contour plates and a spring loaded compensating system. Heats from both sides of tire for maximum repair efficiency. 36269 Optional Stand supports tire on roller assembly for easy rotation. Horizontal vulcanizer makes alignment with repair easy and eliminates stress from repair area. Optional 36277 Contour Plate Set is required for new installations. Includes four, 4" plates. See page 337 for details.

Order No.	Mfr. No.	Description	Ship Wt.
36338	T016	LT Vulcanizer, 120V without Plates	44 lbs. - 20 kg.
36340	T016	LT Vulcanizer, 240V without Plates	44 lbs. - 20 kg.
36269	T031	Optional Stand for LT Vulcanizer	75 lbs. - 34 kg.
36277	T153	Optional Contour Plate Set for LT	4 lbs. - 2 kg.
36266	T023	Replacement Solid Heat Unit 120V	
36265	T055	Silicone Rubber Heat Pad (4" Dia.) 120V	
36417	T062	Silicone Rubber Air Seal (4" Dia.) 120V	
36264	T121	Detachable Electric Cord	

WINNER Bead Spotter

Repairs damaged beads in passenger and truck tires with inside and outside contour plates matching the tire size. Includes one set of plates for 11-22.5 and 11-24.5 tires. Other plate sizes are available for passenger and truck tires. Each inside and outside heater draws 485 watts on 100 V.A.C.



Shown on Optional Stand

Order No.	Mfr. No.	Description	Ship Wt.
36603	TT-15	Bead Vulcanizer 120V	140 lbs. - 63 kg.
36602	TT-15	Bead Vulcanizer 240V	140 lbs. - 63 kg.
36605	TT-15S	Optional Stand	75 lbs. - 34 kg.

LINCOLN 400B Electric Truck Tire Spotter

- Throat depth 6-¼"
- Throat height 9-½"
- Spotter plates see page 337
- Application: shoulder, tread, sidewall repairs
- Maximum injury size 3-½"

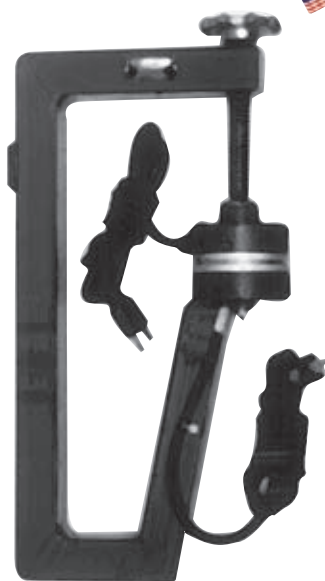

Allows repairs in tires up to 12.00 cross section. High performance heat units feature plate mounted, preset (European approved) thermostats. Heat-up time less than 5 minutes. Optional plate package includes eight plates. See page 88 for details.

Order No.	Mfr. No.	Description	Ship Wt.
36410	400B	Vulcanizer 120V w/o Plates	14 lbs. - 6 kg
36388	400B	Vulcanizer 240V w/o Plates	14 lbs. - 6 kg
36274	T150	Optional Plate Package for 400	8 lbs. - 3 kg
36413	T039	Replacement Heat Unit (Upper) 120V	2 lbs. - 1 kg
36404	T038	Replacement Heat Unit (Lower) 120V	2 lbs. - 1 kg
36415	T039	Replacement Heat Unit (Upper) 240V	2 lbs. - 1 kg
36399	T038	Replacement Heat Unit (Lower) 240V	2 lbs. - 1 kg

LINCOLN 2000TS Air/Electric Truck Tire Spotter

- Throat depth 11-½" (29cm)
- Throat height 24-½" (62cm)
- Spotter plates see page 88



Application: tread sidewall shoulder repairs
 Maximum injury size: 5-1/2"
 Size Range: Low profile truck tires to super single tires

The 6" flexible silicone rubber heat unit conforms to tire sidewall. Capable of repairs up to 5½" on truck tires from low profile to super singles. Control panel has circuit breaker, air regulator, and current indicator lamp. Timer turns off heat, air flow and electricity for unattended shutdown. Indicator lamp shows when cure is complete. 16" Rollers for easy tire rotation. Optional nine piece Plate Package available. See page 88 for details.

Order No.	Mfr. No.	Description	Ship Wt.
36299	2000TS	Vulcanizer w/ Stand 120V without Plates	203 lbs. - 92 kg
36297	2000TS	Vulcanizer w/ Stand 240V without Plates	203 lbs. - 92 kg
36280	T156	Optional 9-Piece Plate Pkg. for 2000TS	32 lbs. - 15 kg
36263	T060	Replacement Solid Heat Unit 120V	
31624	T057	Silicone Rubber Heat Pad (6" Dia.) 120V	
36418	T063	Silicone Rubber Air Seal (6" Dia.) 120V	
36264	T121	Detachable Electric Cord	

LINCOLN MT Air/Electric Medium Truck Tire Spotter

- Throat depth 8-¼" (21 cm)
- Throat height 19" (48 cm)
- Maximum injury size 5-½"
- Spotter plates see page 88



Application: tread, shoulder, & sidewall repairs

Shown with Optional Stand

Repair the tread, shoulder, and sidewall areas of medium sized (8:25 through 12:00) truck tires. Piston pad air head produces professional looking sidewall repairs. Tread and shoulder areas are solidly repaired with constant pressure provided by contour plates and a spring loaded compensating system. Heats from both sides of tire for maximum repair efficiency. 36269 Optional stand supports tire on roller assembly for easy rotation. Horizontal vulcanizer makes alignment with repair easy and eliminates stress from repair area. Optional 36279 Contour Plate Set is required for new installations. Includes 5 plates. See page 88 for details.

Order No.	Mfr. No.	Description	Ship Wt.
36342	T022	MT Vulcanizer, 120V w/o Plates	51 lbs. - 23 kg
36344	T022	MT Vulcanizer, 240V w/o Plates	51 lbs. - 23 kg
36269	T031	Optional Stand For MT Vulcanizer	75 lbs. - 34 kg
36279	T155	Optional Contour Plate Set for MT	15 lbs. - 7 kg
36263	T060	Replacement Solid Heat Unit 120V	
31624	T057	Silicone Rubber Heat Pad (6" Dia.) 120V	
36418	T063	Silicone Rubber Air Seal (6" Dia.) 120V	
36264	T121	Detachable Electric Cord	

LINCOLN 1000 Large Truck/Tractor Spotter

- Throat depth 14-½"
- Throat height 16"
- Spotter plates see page 88
- Application: tread, sidewall, shoulder repairs
- Maximum injury size 3-½"



Spring loaded lower heat unit maintains continuous, even pressure during curing and eliminates retightening of heat units. Screw-driven upper heat unit for last minute adjustments. Use with pliable contour bags or plates. Optional Plate Package includes eleven plates and four bags. See page 88 for details.

Order No.	Mfr. No.	Description	Ship Wt.
36282	1000	Vulcanizer 120V without Plates	30 lbs. - 14 kg
36398	1000	Vulcanizer 240V without Plates	30 lbs. - 14 kg
36276	T152	Optional Plate Pkg for 1000	15 lbs. - 7 kg
36413	T039	Replacement Upper Heat Unit 120V	
36415	T039	Replacement Upper Heat Unit 240V	
36290	T044	Replacement Lower Heat Unit 120V	
36262	T044	Replacement Lower Heat Unit 240V	

LINCOLN 2500 Multi-Use Tire Spotter



- Agricultural, skidder & other OTR tire repairs
- Throat depth 18" (46cm)
- Throat height 32-1/2" (83cm)



Application: Tread, Sidewall Shoulder Repairs

Ideal size to handle tire repairs on light and medium construction equipment, tractors and logging, skidder and mining equipment. Handles tires from 20.5 x 25, OTR sizes up to 29.5 x 35 and skidder tires up to 30.5 x 32. Large 8" x 11" inside and 8" x 15" outside. Adjust-A-Plate contour plate system conforms heating surface to tire contours. Air-actuated bag applies over 5,000 lbs. of pressure evenly over the repair area. Five hour timer automatically shuts off heat unit when cycle is complete. Includes wheeled cart for maximum mobility. Shipped fully assembled.

Order No.	Mfr. No.	Description	Ship Wt.
36270	2500	Multi-Use Vulcanizer 120V	950 lbs. - 432 kg
36271	2500	Multi-Use Vulcanizer 240V	950 lbs. - 432 kg

LINCOLN GT2B Giant Tire Spotter



- Throat depth 14-1/2"
- Throat height 31-1/2"
- Application: tread & sidewall repairs maximum injury size 4-1/2"



For small spot repairs and plugs. Curing heads are 4 3/8" x 6 3/8". Spring loaded lower heat unit maintains continuous, even pressure throughout the curing process. Cure the plug with vulcanizer and apply a chemical patch. Includes two T096 Pliable Contour Bags.

Order No.	Mfr. No.	Description	Ship Wt.
36288	GT2B	Giant Tire Vulcanizer 120V	58 lbs. - 26 kg
36396	GT2B	Giant Tire Vulcanizer 240V	950 lbs. - 432 kg
36323	T096	Pliable Contour Bag (Long Strap)	2 lbs. - 1 kg
36405	T045	Upper Heat Unit 120V	4 lbs. - 2 kg
36406	T046	Lower Heat Unit 120V	4 lbs. - 2 kg

LINCOLN 1400 Air/Electric Tractor Tire Spotter



- Throat depth 14-1/2" (36.5 cm)
- Throat height 16" (40 cm)
- Spotter plates see page 88
- Application tread, sidewall shoulder repairs

PARTS LIST ON PAGE 88

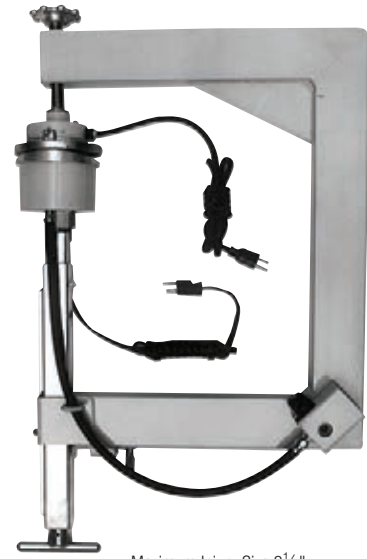

Maximum Injury Size 3 1/2"

Deeper throat depth and height is ideal for large tractor and small off-the-road tires. The optional 1400 Plate Package includes eight plates and 2 bags. See page 88 for details.

Order No.	Mfr. No.	Description	Ship Wt.
36293	1400	Vulcanizer 120V without Plates	28 lbs. - 13 kg
36292	1400	Vulcanizer 240V without Plates	28 lbs. - 13 kg
36278	T154	Optional Plate Pkg. for 1400	12 lbs. - 6 kg
36413	T039	Replacement Upper Heat Unit 120V	
31623	T051	Silicone Rubber Heat Pad (4" Dia.) 120V	
36417	T062	Silicone Rubber Air Seal (4" Dia.) 120V	
36264	T121	Detachable Electric Cord	

LINCOLN OTR Tire Spotter



- Throat depth 26"
- Throat height 44"

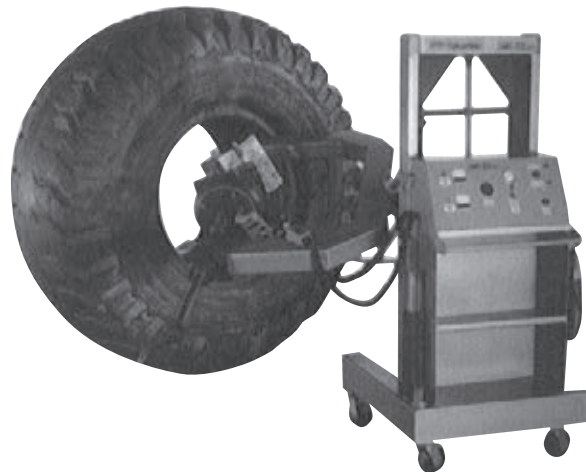

Requires only one operator. Accommodates tires from 20.5 x 25 to 45/65 x 45. Remote-control air cylinder raises and lowers vulcanizing unit. Thermostatically-controlled Adjust-A-Plates conform to tire contours. Air-actuator bag applies consistent pressure across repair area. Four swivel casters for easy rotation and maximum mobility. Twelve-hour timer shuts heat unit off when curing cycle is complete. Extension shafts supplied to accommodate various tire sidewall depths. Available in 120V - 15 amps. Contour plate size 12" x 15", 31 cm. x 38 cm., two curing heads, air pressure 125 psi, 9 bar. Shipped fully assembled.

Order No.	Mfr. No.	Description	Ship Wt.
36375	T030	OTR Tire Spotter 120V	2,000 lbs. - 909 kg

WINNER "AS" Air Operated Tire Spotter

- For spot repairs inside & outside 14" through 11.00-24.5
- Steam units available

PARTS LIST ON PAGE 87



Cure spot repairs on all passenger and truck tires through 11.00-24.5. Swinging Pressure Screw and Heating Assembly applies air pressure and heat to the tire with it hanging in perpendicular position. Optional Tubeless Tire Kits consist of an inside mandrel to supply curing heat to the inside of tubeless tires.

Order No.	Mfr. No.	Description	Ship Wt.
36607	AS	Vulcanizer, Compl. w/ 10 Plates Passenger & Truck 120V	360 lbs. - 163 kg
36499	AS	Vulcanizer, Compl. w/ 10 Plates Passenger & Truck 240V	360 lbs. - 163 kg
36634	AS-T4	Vulcanizer & Stand w/ 4 Truck Plates Only 120V	320 lbs. - 145 kg
36608	AS-PTK-15	15" Pass. Tubeless Kit 120V	25 lbs. - 12 kg
36609	AS-PTK-14	14" Pass. Tubeless Kit 120V	25 lbs. - 12 kg
36610	AS-PTK-14	14" Pass. Tubeless Kit 120V	25 lbs. - 12 kg
36616*	AS-106	Pass. Sidewall Plate 5" x 9"	2 lbs. - 1 kg
36617*	AS-104	Pass. Shoulder Plate 5" x 9"	4 lbs. - 2 kg
36618*	AS-105	Pass. Thread Plate 5" x 9"	4 lbs. - 2 kg
36619*	AS-60R	Truck Sidewall Plate 6" x 9 1/2"	7 lbs. - 3 kg
36620*	AS-61R	Truck Shoulder Plate 6" x 9 1/2"	7 lbs. - 3 kg
36621*	AS-62R	Truck Tread Plate 6" x 9 1/2"	7 lbs. - 3 kg
36622*	AS57-R	Radial Pass. Sidewall Plate 5 1/2" x 9"	6 lbs. - 3 kg
36623*	AS58-R	Radial Pass. Shoulder Plate 5 1/2" x 9"	6 lbs. - 3 kg
36624*	AS59-R	Radial Pass. Tread Plate 5 1/2" x 9"	6 lbs. - 3 kg
36646*	AS41R	Truck Plate 6 1/4" x 8 3/4"	6 lbs. - 3 kg
36632	ASSR	Sidewall Repair Kit Truck 120V	11 lbs. - 5 kg
36633	ASSKID	Skid Repair Kit Truck 120V	11 lbs. - 5 kg

*These Contour Plates included with AS Vulcanizer Complete

MONAFLEX OTR Bead Repair System

- XLOTRS Extra large OTR bead repair system

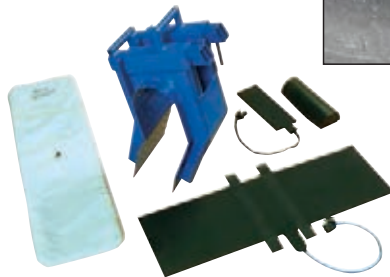

The heat pad and airbag are secured beneath a steel support allowing bead repairs in tire sizes from 4000-57 to 55.5 /85.63. The unit breaks down into two sections allowing easy transport and storage. The entire system can be assembled on the tire in under two minutes.

Order No.	Mfr. No.	Description
34707	TRRS (15)	Control Panel
34095	XLBRSH	Steel Frame
34602	XLBRS 4112H	Heat Pad
34603	XLBRS 13 x 4.75H	Heat Pad
34860	XLBRS 43.5 x 13A	Flat Air Bag
34096	XLBRS BB	Bead Block

MONAFLEX TRDD Truck Tire Section Repair

- 8.25-20 Through 12.00-24 range
- No heavy metal frame



The system uses inside and outside heat pads, strapping system and inflatable air bags for versatile truck tire section repair system. Timer switch actuates the power. Heat pad temperature is preset at 284° F. System consists of: control panel, bias heat pad, inside radial heat pad, curing pack, harness straps, and cylinder air bag. Custom Quotes Available: Submit smallest and largest tire sizes for repair.

Order No.	Mfr. No.	Description	Ship Wt.
34920	TRDD	Truck Section Repair 220V	120 lbs. - 54 kg

MONAFLEX OTR Sidewall Repair System

- OTRS Sidewall or XLOTRS extra large sidewall system



For the repair of sidewalls in radial and cross ply tires from 1400 x 24 through 29.5 - 29 plus skidder and terra tires. Complete assembly in two to three minutes. Cures repair unit and plug in one operation.

XLOTRS system was developed for the repair of sidewall injuries of size 4000-57 to 55.5/ 85.63. The unit breaks down into four sections for easy of transport and assembly by two tire repairmen.

34950 Complete OTRS Sidewall System

Order No.	Mfr. No.	Description
34707	TRRS (15)	Control Panel
34094	OSH	Housing
34065	M4832S	Heat Pad

Order No.	Mfr. No.	Description
34606	OSH2815HP	Heat Pad
34840	OS2117A	Flat Air Bag
34850	OS2517	A Flat Air Bag

34970 Complete XLOTRS Sidewall System

Order No.	Mfr. No.	Description
34700	MC	Control Panel
34097	XLOTRS SW	Steel Frame
34608	M45.5 x 20H	Outside Heat Pad
34607	M5620H	Inside Heat Pad

Order No.	Mfr. No.	Description
	XLOTRS BB	Rubber Bead Block
34880	M45.5 x 20	Outside Air Bag
34870	M56 x 20	Inside Air Bag
34098	XLOTRS P	Repl. Pannier

VULCAN Lug Filler Bags

- Use to fill lugs & prevent cushion flow & damage to heat pads

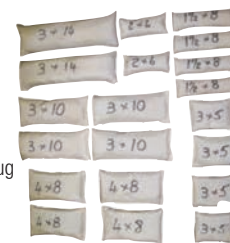

Silica sand-filled tread lug filler bags are the best alternative to plaster of paris or aluminum foil.

The sand is very fine allowing them to take the shape of the tread void. Kit includes 20 bags of the following sizes: (4) 1.5" x 8", (2) 2" x 6", (4) 3" x 5", (4) 3" x 10", (4) 4" x 8" and (2) 3" x 14".

Order No.	Description
34757	Lug Filler Bags

Monaflex Section Repair

MONAFLEX OTR Custom Components

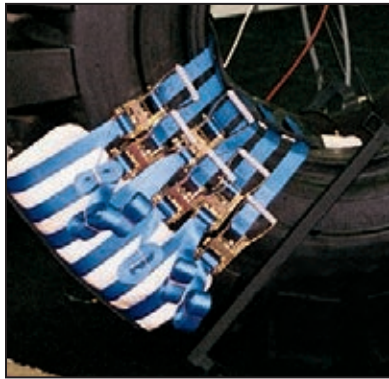

Custom Systems can be designed to accommodate specific tire size ranges. Control Panel and Harness are required. Order air bags and heat pads as required. See Component Chart below. MONAFLEX OTR Systems available 1300-24 through 55.5 /80-63. For a quote call your Myers Professional.

Order No.	Mfr. No.	Description	Ship Wt.
34701	M100	OTR Control Panel – 220V	50 lbs. - 23 kg
34700	MC	OTR Control Panel – 220V	50 lbs. - 23 kg
34572	M45/6 /7(1HG)	OTR Harness (Set/6)	34 lbs. - 15 kg
34566	TROC/SXL	XL Straps (Set/5)	2 lbs. - 1 kg
34530*	TR2621EPC	Outside Curing Pack Only	30 lbs. - 14 kg
34540**	M4832EPC	Outside Curing Pack Only	30 lbs. - 14 kg

* Must order separate 36220 (M2621H) Heat Pad - See chart below

** Must order separate 36073 (M2626H) Heat Pad - See chart below

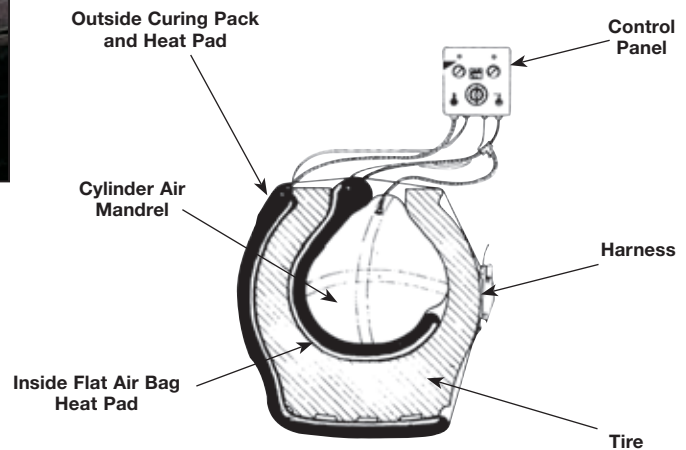

Component Chart

NOTE: The chart below is for guidance only. The final choice depends on: size of injury, number of plies injured, and size of patch recommended. Choose inside heat pad large enough to cover the patch. Because of variations in tire sizes and dimensions a smaller or larger air bag may be required. It may be necessary to measure the inside cross section of the tire to determine the correct fitting cylinder air bag and if a flat inside bag is required.

OTR Wide Base & Tractor Size	OTR Sizes	Cylinder Air Bag	Inside Flat Air Bag	Inside Heat Pad		Outside Heat Pad	Outside Curing Pack	Harness Complete
				Bias	Radial			
14.4-24 to 16.9-38	13.00 to 17.5	TR1315/20WA	–	M2519H	M3015	TR2621H	TR2621E	TROC-SXL
18.4-34 to 20.8-42	18.00 to 21.00	M1721/24WA	–	M2519H M2626H	M3015H	TR2621H	TR2621E	TROC-SXL
23.1-26 to 30.5-32	23.5 to 26.5	M1721/24WA	M4824WA	M2519H M2626H	M3015H	TR2621H	TR2621E	TROC-SXL
25/65-25	27.00 to 29.5-29	M1721/24WA	M4824WA or M5432WA	M2519H M2626H	M3015H M4220H	TR2621H	TR2621E	TROC-SXL
40/65-39, 45/65-45, 35/65-33	30.00 to 37.5	M2732/32WA	M5432WA	M2626H M3132H	M4220H M4224H	M2626H	M4832E	M45/6/7 (1HG)
49.5/85-57 to 50/65-51	40.00	M3842/32WA	–	M3132H	M4220H M4224H M4824H M5224H		M4832E	M45 /6 /7 (1HG)

MONAFLEX Heat Pads, Air Bags, Harness Straps & Curing Packs

Note: Recommended air pressure 32 psi for Cylinder Bags & 28 psi for Flat Air Bags

Heat Pads – 220V

Order No.	Mfr. No.	Heated Area
34617	M1616H	16" x 16"
34614	TR2213H	19" x 12"
34612	TR2210H	19" x 9"
34618	M2519H	25" x 19"
34616	TR2621H	22 1/2" x 19"
34619	M2626H	26" x 26"
34620	M3132H	31" x 32"
34623	M3015H	30" x 15"
34621	M3636H	36" x 36"
34624	M4215H	41" x 15"
34625	M4220H	42" x 20"
34626	M4224H	42" x 24"
34628	M4824H	48" x 24"
34629	M5224H	52" x 24"

Cylinder Air Bags

Order No.	Mfr. No.
34150	*TR910/11W
34160	*TR911/13W
34360	M1220A
34170	*TR1315/15WA
34180	*TR1315/20WA
34370	M1518/24A
34440	*M1721/24WA
34190	*TR1921/20WA
34380	M2124A
34390	M2427/32A
34450	*M2427/32WA
34460	*M2732/32WA
34410	M3336/32A
34470	*M3336/32WA
34420	M3842/32A
34480	*M3842/32WA
34430	M4447/32A
34490	*M4447/32WA

* Window Style

Flat Air Bags

Order No.	Mfr. No.
34010	TR2210A
34120	TR2213A
34020	M2316A
34130	TR2621A
34210	M2820A
34140	TR3620A
34027	M3624A
34300	*M4824WA
34033	M4824A
34320	*M5432WA
34240	M5432A
34330	*M6732WA
34260	M6732A
34270	M7532A
34350	*M9032WA
34280	9032A

* Window Style

Harness Sets

Order No.	Mfr. No.
34562	TROC3 - 3 Straps 2.5 Meters Lg.
34563	TROC4 - 4 Straps 2.5 Meters Lg.
34564	TROC5 - 5 Straps 2.5 Meters Lg.
34566	TROC-SXL - 5 Straps 3.5 Meters Lg.
34569	M45/6 - 6 Straps 6 Meters Lg.
34571	M45/6/7 - 6 Straps 7 Meters Lg.
34572	M45/6/7/1HG - Used only with M4832 Curing Pack

Curing Packs: Outside Air Bags with Strap Guides Only

Order No.	Mfr. No.
34510	TR219EPC
34521	TR2213EPC
34530	TR2621EPC
34540	M4832EPC

VULCAN-VULCAP VRC OTR Tire Repair Clamp

- Range 18.00-25 through 36.00-51
- Optional extended arms increase size range to 45/65/45
- Optional lug filler bags available - see page 45

A portable OTR repair unit for tread, shoulder and sidewalls. Spotter heads raised and lowered by a manual hydraulic lift. Twin heat pads reduce distortion and have built-in thermostats to maintain constant curing temperature. Specify 115v or 230v; requires 70 to 80 psi.

Order No.	Mfr. No.	Description	Ship Wt.
34752	1002969	Vulcan OTR Clamp	800 lbs. - 364 kg



VULCAN-VULCAP Section Molds

Inflatable mandrel packages feature heat resistant rubber cores and outside high tensile nylon covers for maximum service life. Built-in thermostats in heat pads provide reliable temperature control.

RTV 12

- Range: truck 8.25 x 15 to 12.00 x 24

Truck mold includes air bag, outside heat pad, two bead filler pads, air differential control panel, and inflatable mandrel package.

Order No.	Mfr. No.	Description	Ship Wt.
36810	012000	RTV 12 Section Mold	250 lbs. - 113 kg

V14

- Range: truck - 8.25 x 20 - 12.00 x 24

Truck Mold includes built-in spreader, air bag, outside heat pad, two bead filler pads, air differential control panel and M2 inflatable mandrel package.

Order No.	Mfr. No.	Description	Ship Wt.
36762	202200	V14 Section Mold	745 lbs. - 335 kg

Options

36663	240700	M2.25 Low Profile Inflatable Mandrel Range: 255/70R 22.5; 275/80R, 22.5/24.5; 255/80R 22.5	16 lbs. - 8 kg
36664	203700	Low Profile Inflatable Mandrel Kit Use with M2 Pkg. for Extra Pressure on Shoulder & Sidewall Area	10 lbs. - 5 kg

MV20

- Range: truck - 14.00 x 24, 18.00 x 22.5; tractor - 13.6 x 24, 18.4 x 38; grader - 12.00 x 24, 17.5 x 25

MV20 Section Repair Mold 220V includes: air bag, two bead filler pads, side filler pad, outside heat pad, air differential control panel, and M4 Inflatable Mandrel package.

Order No.	Mfr. No.	Description	Ship Wt.
36661	20092	MV20 Repair Mold - for Complete Tire Range, M3 Pkg as an Extra is Required	850 lbs. - 385 kg

M3 Inflatable Mandrel Package

- For Use With SM180, SM250, V20 & MV20
- Range: truck/tractor/grader - 13.00-16.9
- Call for Details

M5 Inflatable Mandrel Package

- For Use With MV30
- Range: tractor/em - 18.00-23.1
- Call for Details



MV30

- Range: 18.00 x 24 - 24.00/35

MV30 OTR Section Repair Mold 220V Single phase 20 amps. Includes: air bags, two bead filler pads, side filler pad, bottom filler pad, outside heat pad, air differential control panel and M6 inflatable mandrel. Package with expandomatic air bag 33" x 55". To cure from 23.5 to 29.5 with 36645 top clamp extension must be purchased. Both M5 and M6 package required for tire ranges listed.

Order No.	Mfr. No.	Description	Ship Wt.
36676	30092	MV30 Repair Mold	1,200 lbs. - 544 kg
Options			
36645	300700	Top Clamp Extension - Enables Machine to Handle Tire Sizes Up to 29.5 x 25/29	20 lbs. - 9 kg

MV40A (Adjustable)

- Range: 27.00 x 49-37.5 x 33

MV40 OTR Section Repair mold 220V single phase 25 amps. Includes: air bag, two bead filler pads, side and bottom filler pads, outside heat pad, air differential control panel and M8 inflatable mandrel package with expandomatic air bag 37" x 66".

Order No.	Mfr. No.	Description	Ship Wt.
36647	40092	MV40A Repair Mold	1,400 lbs. - 635 kg

MV50A (Adjustable)

- Range: 36.00 x 51, 45/65/45

MV50A OTR Section repair Mold 220V single phase 25 amps. Includes: Air bags, two bead filler pads, side and bottom filler pads, outside heat pad, air differential control panel and M8 inflatable mandrel package with expandomatic air bag 37" x 80".

Order No.	Mfr. No.	Description	Ship Wt.
36625	50092	MV50A Repair Mold	1,750 lbs. - 795 kg

VULCAN-VULCAP Section Mold Replacement Components

Air Bags for Passenger & Truck Molds



Outside Air Bags

Order No.	Mfr. No.	Description	Ship Wt.
36691	901700	MPB Bag (12.5" x 30")	9 lbs. - 4 kg
36824	0120500	RTV Main Bag (40" x 12")	15 lbs. - 7 kg
36699	140920	MT Bag (22" x 43")	18 lbs. - 8 kg
36702	140410	MTB Bag (22" x 45")	23 lbs. - 11 kg
36957	201800	V14 Bag (21" x 40")	20 lbs. - 9 kg
36944	814100	V14 Spreader Bag (15" x 19.5")	8 lbs. - 4 kg
36705	816700	SM180 Main Bag (22" x 36.5")	20 lbs. - 9 kg
36708	816800	SM180 Side Bag (22" x 16")	13 lbs. - 6 kg
36648	814000	SM180 Spreader Bag (11.5" x 19.5")*	7 lbs. - 4 kg
36944	814100	SM180 Spreader Bag (15" x 19.5")	8 lbs. - 4 kg
36709	256240	SM250 Main Bag (22" x 43")	23 lbs. - 11 kg
36712	256500	SM250 Side Bag (22" x 19")	14 lbs. - 7 kg
36944	814100	SM250 Spreader Bag (11.5" x 19.5")	8 lbs. - 4 kg
36832	221600	V20 Air Bag (22.5" x 64")	33 lbs. - 15 kg
36944	814100	V20 Spreader Bag (15" x 19.5")	8 lbs. - 7 kg
36649	020400	MV20 Air Bag (65" x 20")	40 lbs. - 18 kg

Inside Flat Air Bags

36792	891100	Vulcamatic "A" Bag 20" x 30"	16 lbs. - 8 kg
36793	891200	Vulcamatic "B" Bag (20" x 40")	19 lbs. - 9 kg
36794	259300	Vulcamatic "C" Bag (20" x 50")	24 lbs. - 11 kg

*For SM180 Molds after serial #1500, use larger spreader bag #814100

Air Bags for Earthmover Molds

Outside Air Bags

Order No.	Mfr. No.	Description	Ship Wt.
36716	182900	V18 Bag (33" x 71")	74 lbs. - 34 kg
36717	214600	V21 Main Bag (33" x 58")	54 lbs. - 25 kg
36718	214500	V21 Side Bag (26" x 33")	25 lbs. - 12 kg
36650	300100	MV30 Main Bag (84.5" x 30")	65 lbs. - 30 kg
36717	214600	V310 Air Bag (Mold Requires 2) (33" x 58")	54 lbs. - 25 kg
36719	372200	V37.5 Main Bag (37" x 74")	73 lbs. - 33 kg
36720	372100	V37.5 Side Bag (37" x 36")	38 lbs. - 18 kg
36651	405100	MV40 Main Air Bag (81" x 35")	70 lbs. - 32 kg
36652	405000	Side Air Bag (44" x 35")	45 lbs. - 21 kg
36797	500100	V45 Main Bag (95" x 37")	95 lbs. - 43 kg
36798	500200	V45 Side Bag (48" x 37")	49 lbs. - 22 kg
36653	501400	MV50 Main Air Bag (103" x 40")	100 lbs. - 46 kg
36654	501300	MV50 Side Air Bag (50" x 40")	70 lbs. - 32 kg

Inside Flat Air Bags

36655	210300	Expandomatic Bag (33" x 55") V310/V21/MV30/V18	38 lbs. - 18 kg
36659	376100	Expandomatic Bag (37" x 45") V33/MV40	45 lbs. - 21 kg
36723	376300	Expandomatic Bag (37" x 56") V33/V37.5/V45/MV40/MV50	56 lbs. - 26 kg
36724	376000	Expandomatic Bag (37" x 66") V33/V37.5/V45/MV40/MV50	66 lbs. - 30 kg
36997	376600	Expandomatic Bag (37" x 80") V33/V37.5/V45/MV40/MV50	80 lbs. - 37 kg

Tire Talc (MICA)



Keeps casings, tubes, rims and patches from adhering to each other. Ideal for dusting curing tubes, air bags, etc.

Order No.	Mfr.No.	Description	Ship Wt.
46608	RM-23	1 lb. Can	1 lbs. - 1 kg
46610	RM-23X	50 lb. Bag	55 lbs. - 25 kg

Outside Heat Pads

Outside Heat Pads: Specify Voltage

Order No.	Mfr. No.	Description	Ship Wt.
36812	012600	RTV Outside Heat Pad	18 lbs. - 8 kg
36958	200500	V14 Heat Pad	30 lbs. - 14 kg
36739	856000	MT/MTB/SM180 Heat Pad	39 lbs. - 18 kg
36814	221500	V20 Heat Pad	45 lbs. - 20 kg
36744	251000	SM250 Heat Pad	54 lbs. - 25 kg

Earthmover: Specify Voltage

36742	214800	V18/V21 Heat Pad	90 lbs. - 41 kg
36743	372400	V33/V37.5 Heat Pad	150 lbs. - 68 kg
36713	300500	MV30 Heat Pad	90 lbs. - 41 kg
36714	405200	MV40 Heat Pad	150 lbs. - 68 kg
36715	502600	MV50 Heat Pad	185 lbs. - 84 kg

Inside Heat Pads

Inside Heat Pads

Order No.	Mfr. No.	Volt	Application	Overall Size	Ship Wt.
36734	904892	220	MPB "AAA"	9" x 9"	4 lbs. - 2 kg
36735	903791	110	MPB "AA"	12" x 12"	5 lbs. - 3 kg
36736	903792	220	MPB "AA"	12" x 12"	5 lbs. - 3 kg
36946	204991	110	SM180/V14 "A"	16" x 19"	10 lbs. - 5 kg
36947	204992	220	SM180/V14 "A"	16" x 19"	10 lbs. - 5 kg
36790	856191	110	SM180 "B"	22" x 22"	18 lbs. - 8 kg
36799	856192	220	SM180 "B"	22" x 22"	18 lbs. - 8 kg
36800	259792	220*	SM250 "C"	33" x 23"	34 lbs. - 16 kg
36802	210192	220*	V21/V310/MV30	28" x 28"	41 lbs. - 19 kg
36730	376292	220*	V33/V37.5/MV40	32" x 32"	90 lbs. - 41 kg

*Not available in 110V

VULCAN-VULCAP Section Mold Inside Air Mandrels



Order No.	For System	Description	Ship Wt.
36673	MO	920000 MO Mandrel	5 lbs. - 3 kg
36675	RTV	012800 RTV Mandrel	10 lbs. - 5 kg
36948	M2	201700 M2 Mandrel V-14	27 lbs. - 6 kg
36664	M2	Low Profile Flat Bag 203700 Kit V-14	10 lbs. - 5 kg
36663	M2.25	Low Profile 204700 M2.25 Mandrel	16 lbs. - 8 kg
36685	M3	253700 M3 Mandrel	18 lbs. - 9 kg
36687	M4	253200 M4 Mandrel	23 lbs. - 11 kg
36688	M5	216300 M5 Mandrel	32 lbs. - 15 kg
36689	M6	215900 M6 Mandrel	36 lbs. - 17 kg
36690	M8	370400 M8 Mandrel	62 lbs. - 29 kg

Heat Insulated Gloves

Retreaders favorite cotton cloth glove. Protection for handling hot molds, mold parts etc. White with red trim. 24 oz.



Order No.	Mfr. No	Description
45300	PE6A	2" Cuff
45301	PE6G	5" Cuff

Green Hot Mill Gloves

Heavy-duty hot mill gloves. Flame-retardant.



Order No.	Mfr. No	Description
45302	SOUFGFT-PK	2" Cuff
45303	SOUFGF-P	5" Cuff

Retreading

Myers Tire Supply is your retread headquarters. It was true when it was first said in 1933 and it's true today. From **BRANICK** spreaders, **ATEC & CRS** inspectors, **B&J** rasps & hubs, **GRACO** sprayers, **VULCAN-VULCAP** tread builders & stitchers, **SURESEAL** sealing rings, **ROBBINS** envelopes & curing tubes, **ELRICK** branders & **PARKER BOILERS**. Myers stocks the most complete line of retread tools, equipment & supplies in the industry.



Wonder Air Vacuum



Powered by compressed air, powerful suction picks up buffing dust and cleans tires. Cleans uncured tire treads before they're placed in matrix. 6' snake hose.

Order No.	Mfr. No.	Description	Ship Wt.
82435	W-100	Vacuum Complete	8 lbs. - 4 kg
Replacement Parts			
82436	W-100C	6' Vinyl-Covered Rubber Hose	
82437	W-100E	1" x 3" Tube for Joining 2 Hoses	
82438	W-100F	Brush	
82439	W-100H	Dust Bag	
49006		Brass Valve	

Jet-Vac



Removes water and other debris from weather-exposed casings. The 4' outlet extension hose is used to deposit water into a pail or other container when the Jet-Vac is operated indoors. Air requirements: 1/4" air line with 100 p.s.i.

Order No.	Mfr. No.	Description	Ship Wt.
82433	JVP	Jet-Vac Pass	3 lbs. - 2 kg
82434	JVT	Jet-Vac Truck	6 lbs. - 3 kg

Truck Tire Spreader

- Spreads to 17"

Locks heavy-duty truck or passenger tire beads in any position. Use in pairs on large truck tires for best results. Excellent as inspection tool. Compact, easy to handle.

Order No.	Mfr. No.	Description	Ship Wt.
50927	T-54	Truck Tire Spreader	8 lbs. - 4 kg

Air Vac

- Venturi vacuum system



Trigger control with an easy-to-clean bag. Includes brush, angle tool and 9" extension.

Order No.	Mfr. No.	Description
82000	VAC-1	Air Vac

Portable Tire Spreader

- Passenger, truck, & small OTR



A powerful hand spreader ideal for service truck work or in the shop. Use a 1 1/4" socket to spread and release. Spreads from 1/2" to 13 1/2".

Order No.	Mfr. No.	Description	Ship Wt.
50929	GTS-01	Tire Spreader	7 lbs. - 3 kg



Tire Spreaders

Speed Tire Spreader

A powerful hand spreader ideal for inspection work or used in pairs for holding beads apart when making section repairs. Includes locking pin to prevent spreader from unlocking during use and instruction sheet.



Order No.	Mfr. No.	Description	Ship Wt.
50926	M-1	Speed Tire Spreader	4 lbs. - 2 kg

Economy Tire Spreader

- For passenger, RV, & light truck tires



Spreads passenger, RV, and light truck tires up to 10". Features two ball bearing rollers and tire sidewall adjustments. Three height adjustments. The large base does not require bolting to the floor.

Order No.	Mfr. No.	Description	Ship Wt.
52156	EZM-50	Tire Spreader	31 lbs. - 14 kg

Floor Mount Tire Spreader

- For passenger, RV & light truck tires 13" to 20"



Features heavy-duty rollers with multiple height and width adjustments and tool tray.

Order No.	Mfr. No.	Description	Ship Wt.
85024	73080	Portable Tire Spreader	63 lbs. - 29 kg

BRANICK 5035 Passenger & Light Truck Tire Spreader

- Ideal for low profile & wide base tires
- Economy model. Does not include gas spring or rollers
- RMA compliant 200 foot candle CFL light



It will handle tires up to a 13" cross section and up to a 40" diameter. Adjustable spreader hooks adapt to varying sidewall heights and widths. Includes 60 watt light mounted on a flexible arm.

Order No.	Mfr. No.	Description	Ship Wt.
52139	5035	Economy Spreader	50 lbs. - 23 kg
52142		Optional Storage Cabinet 12" x 8" x 9 1/2"	
52144		Optional 3" Riser	

Solvent Dispensing Cans



For moistening swabs. Tire casings, repair materials, etc., should be swabbed with rubber solvent to insure the cleanliness necessary for maximum adhesion. Construction of can reduces fire hazard to a minimum. Wastage from spilling is entirely eliminated. Easy to fill.

Order No.	Mfr. No.	Capacity	Ship Wt.
45579	B602	2 Qt.	4 lbs. - 2 kg
45587	B608	8 Qt.	8 lbs. - 4 kg
Plunger-Type Dispensing Can			
45580	P701	1 Qt.	3 lbs. - 2 kg
45581	P702	2 Qt.	3 lbs. - 2 kg

BRANICK 5045 Passenger & Light Truck Tire Spreader

- Ideal for low profile & wide base tires
- Manual spreader with gas spring for controlled tension release
- RMA compliant 200 foot candle CFL light



Shown with optional riser & storage cabinet

It will handle tires up to a 13" cross section and up to a 40" diameter. Adjustable spreader with hooks adapt to varying sidewall heights and widths. Includes light mounted on a flexible arm and zinc-plated rollers. The optional 3" riser attaches to the spreader for an increased working height. The optional storage cabinet is 12" x 8" by 9.5" at the base and 6.5" wide at the top.

Order No.	Mfr. No.	Description	Ship Wt.
52140	5045	Professional Spreader	62 lbs. - 28 kg
52142		Optional Storage Cabinet	
52144		Optional Riser	

BRANICK 5120 Tire Spreader

- Air-Powered
- For passenger, light truck & truck tires up to 12.00-24
- Ideal for tire repair



Tool tray can be put on either side of the spreader. Includes flexible arm light fixture. Foot control valve keeps hands free. The wider platform offers a more stable work surface. Spreader hooks adjust with spring-loaded pins. Requires 75 psi.

Order No.	Mfr. No.	Description	Ship Wt.
52126	5120	Air Powered Tire Spreader	150 lbs. - 68 kg
70400	376-016	Replacement Lamp	3 lbs. - 2 kg

BRANICK LR/EF Spreader



For inspecting, patching, buffing, or inserting tubes and flaps. Handles all passenger and truck tires from 13" through 24" rim diameter; tubeless truck from 16.5 through 24.5 rim diameter. Adjustable hooks are available for aircraft and small commercial tires. Pneumatic tire lift eliminates bending or lifting. Light assembly concentrates light on the inside of the tire.

Order No.	Mfr. No.	Description	Ship Wt.
50746	LR/EF	Tire Spreader	245 lbs. - 111 kg
70400	376-016	Replacement Lamp	3 lbs. - 2 kg

73100 Tire Spreader

- For passenger & light truck



Air operated tire spreader with an adjustable light and a wide platform for a stable work surface.

Order No.	Mfr. No.	Description	Ship Wt.
89218	73100	Tire Repair Station	180 lbs. - 82 kg

BRANICK 5500 Tire Repair Station

- For passenger, light truck & truck tires
- Economical work station for rereaders & section repair shops



Tool tray and spreader controls pivot for right or left handed operation. Foot controls are on both sides of the spreader. Tire ramp retracts when the platform is raised. A powerful 5 1/4" air cylinder lifts the platform. Maximum height is 33" to top of table. Requires 75 psi.

Order No.	Mfr. No.	Description	Ship Wt.
52154	5500	Tire Repair Station	441 lbs. - 200 kg

BRANICK AH/RI/R Adjustable Repair Inspector

- Reverse tire direction for inspection
- Spreads, revolves & inverts
- Lifts 12" to 34-1/2"

Lifting, spreading and inverting are controlled by a pivoting control panel for easy access to either side of the spreader. Foot valve operates the variable speed tire rotation. Air powered cylinder inverts bias tires for section repairs. Adjustable light for increased visibility inside the tire. Handles tires from 13" through 24.5"; up to 48" in overall diameter.



Order No.	Mfr. No.	Description	Ship Wt.
50759	AH/RI/R	Reversible Tire Spreader	592 lbs. - 269 kg

BRANICK EF Tire Spreader

Call for availability of reconditioned units



Parts list on page 85

Air operated tire lift handles all sizes of passenger, truck & bus tires 12" to 28" bead diameter and 4" to 11" cross section. Revolve tires for inspection. Anchoring to floor unnecessary. Convenient floor mounted foot controls.

Order No.	Mfr. No.	Description	Ship Wt.
50754	EF	Spreader	512 lbs. - 232 kg
50616	#541	Foot Control Kit Converts Older EF Spreaders from Hand to Foot Controls	

BRANICK Heavy-Duty EF/HD Tire Spreader

Call for availability of reconditioned units



Parts list on page 85

Air operated tire lift for all truck, bus and some airplane tires. Sizes thru 14.00 x 24" 20 ply. Revolves tires 360°. Convenient floor mounted foot controls.

Order No.	Mfr. No.	Description	Ship Wt.
50751	EF/HD	Spreader	800 lbs. - 363 kg

BRANICK S-FLL Tire Spreader



Built low for fast, easy handling of heavy tires. Tire support rollers are near floor so larger tires can be rolled onto spreader. One person operation, floor foot-valve control. Handles 16:00-24 tires.

Order No.	Mfr. No.	Description	Ship Wt.
50643	S-FLL	Tire Spreader	163 lbs. - 74 kg

Tire Inspection

HAWKINSON NDT III Tire Inspector

- Detector circuit finds more flaws than the NDT II
- Automatically stops at injury
- Inspect more than 100 tires in an 8-hour shift, reduce inspection time by 43%



Test light commercial, medium truck, bus and super single tires before buffing. The units stops automatically when an injury is detected. The adjustable table allows the operator to inspect tires at any height. The NDT III uses electrical impulses to detect nails, nailholes, cuts, tears and bad repairs not visible to the eye. Takes only 20 seconds per tire. Foot-activated tire lift automatically raises tire to the inspection level. Specify voltage.

Order No.	Mfr. No.	Description
57656	NDT III	Tire Inspector

HAWKINSON NDT II Tire Inspector

- Finds penetrations before they cause separations
- Automatically stops at injury
- More models available contact us

Parts list on page 89



Test radial and bias light commercial, medium truck, bus and super singles before buffing. The inspector is free-standing so tires can be inspected at anytime and the units stops automatically when an injury is detected. The NDT II uses electrical impulses to detect nails, nailholes, cuts, tears and bad repairs not visible to the eye. Takes only 32 seconds or less per tire. Foot-activated tire lift automatically raises tire to the inspection level. Specify voltage.

Order No.	Mfr. No.	Description	Ship Wt.
52150	NDT II	Tire Inspector	1,100 lbs. - 495 kg

Replacement Assemblies

54456	NDT	Bead Rollers (Set of 2) 1 1/2" Dia. x 3 1/8" L.
54455	NDT	Spread Rollers (Set of 4) 1 1/4" Dia. x 3 1/8" L.
52158	H00-0724	Light Package

HAWKINSON NDT Probe Assemblies

- For Hawkinson NDT inspectors

Parts list on page 89



Order No.	Description
57648	14" Probe Assembly for 14" & 15" Bead Diameter Tires
57649	Light Truck Probe Assembly for 16" Thru 19.5 Bead Diameter Tires
57650	Medium Truck Probe Assembly for 20" Thru 24.5 Bead Diameter Tires
57651	315 Truck Probe Assembly for 315 / 80R22.5 Tires
57652	Wide Base Probe Assembly for Most Super Single Wide Base Tires
57653	X-1 Wide Base Probe Assembly for X-1 Tire Sizes 445 / 50R22.5 & 455 / 55R22.5

MYERS Hand Held Nailhole Leak Detector

- Quick & easy method to check tires for nailholes



Detect nailholes in any size tire. Tires must be free of all moisture. A foot switch activates the detector as it's passed over the innerliner. A humming noise and electrical glow will be signal a nailhole has been detected. Includes wall unit, foot switch and "T" handle detector probe.

Order No.	Description	Ship Wt.
46003	Hand Held Nailhole Wand-Type Leak Detector	20 lbs. - 9 kg

HAWKINSON Micro-NDT Tire Inspector

- Portable & manually operated
- Same proven technology as the NDT II



Detect nailholes in any size tire before they become a problem. Use with any tire spreader.

Order No.	Mfr. No.	Description
52163	Micro-NDT	Steel Only, Manual Stop Tire Inspector
52164	Micro-NDT	Steel & Fabric, Manual Stop Tire Inspector
57654	Micro-NDT	Steel Only, Auto Stop Tire Inspector
57655	Micro-NDT	Steel & Fabric, Auto Stop Tire Inspector

HAWKINSON NDT-2000 Tire Inspector

- Improved testing capability & flexibility
- Same proven technology as the NDT II



Test light commercial, medium truck, bus and super single tires before buffing. The units stops automatically when an injury is detected. The NDT-2000 uses electrical impulses to detect nails, nailholes, cuts, tears and bad repairs not visible to the eye. Takes only 32 seconds per tire. Foot-activated tire lift automatically raises tire to the inspection level. Specify voltage.

Order No.	Mfr. No.	Description
57657	NDT-2000	Tire Inspector

HAWKINSON NDT Replacement Chains & Wires

- Authentic replacements for Hawkinson NDT Probe Assemblies

Order No.	Mfr. No.	Description
54449	NDT	Chains (Set/32)
54448	NDT	B to B 19" Med. Truck Wire
54447	NDT	B to B 13" Light Truck Wire
54446	NDT	B to B 16" Combo Wire
54444	NDT	Metal Inserted Wire 19" Med.
54445	NDT	B to B 26 1/2" Wire Wide Base

ATEC Insta/Spect-I Inspection/Repair Station



Light Included

Use for repair, initial or final inspection. Two 4" lifting cylinders raise a 300 lb. tire at 125 psi. A separate 4" cylinder spreads tire beads. Automatically adjusts from 26" to 46" diameter x 20" cross section. Diameters can be modified for larger or smaller sizes. 4 HP air motor. Requires 125 psi, 1/2" air inlet.

Order No.	Description	Ship Wt.
45221	Model 9 Intal/Spect-I (Light Included)	750 lbs. - 338 kg

ATEC NDT Model 15 Inspector



- Finds penetrations before they can cause separations
- Automatically stops at the injury
- Proven Hawkinson NDT technology



Roller height down 61/2", roller height up 47". Probe sizes, 14" through 15" bead diameters; 16" through 19.5" diameters; radial 255R22.5 through 12R24.5 and bias 900-20 through 1200-24. Includes medium truck probe assembly. Requires 145 psi, 120v, 50/ 60 Hz.

Order No.	Description	Ship Wt.
45227	Model 15 NDT Inspector	1,350 lbs. - 608 kg
45228	Optional Light Pkg. 110v., 15 amp	75 lbs. - 34 kg
45229	Optional Work Bench	500 lbs. - 225 kg

CRS Heavy-Duty Tire Buffers

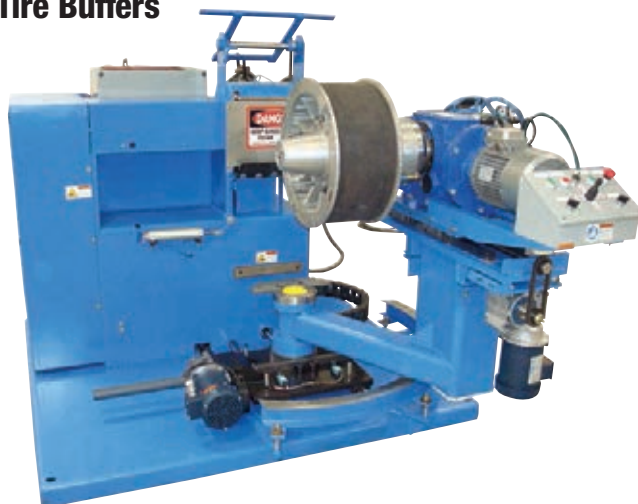

Features a standard 30, 40 or 50 hp drive motor one-to-one ratio templates, hubs, sidewall buffer, automatic traverse system and the precision dove-tail slide assembly. By using stock components and locally available maintenance items, the units allow for quick service and minimal down time. 150 psi required. Specify 220V or 440V 3 ph F.O.B. factory.

CB-40A and **CB50A** Heavy-Duty Truck Tire units: buff from 13" through 14.00 x 24.00 tires.

CB-50G Extra Heavy-Duty Truck and Grader: buffs from 15" through 20.5 x 25. See page 302 for expandable rim assemblies not included with buffers.

Order No.	Mfr. No.	Description	Ship Wt.
31051	CB-40A	Truck Tire Buffer	4,300 lbs. - 1,935 kg
31052	CB-50A	Truck Tire Buffer	4,400 lbs. - 1,996 kg
31053	CB-50G	Truck & Grader Buffer	4,500 lbs. - 2,041 kg
42409	TDW-610	Sidewall Buffing Carbide 6" x 1" Specify 5/8" A.H., 36 Grit	1 lbs. - 1 kg
31027	SW-2	Optional Sidewall Buffing Attachment	100 lbs. - 45 kg

CRS ATB Tire Buffers



- Fully automatic computer controlled buffers
- Store over 2,000 precure & mold cure buffing programs



Features a standard 40 or 50 hp drive motor one-to-one ratio templates, hubs, sidewall buffer, automatic traverse system, built-in belt detector, laser measurement and the precision dove-tail slide assembly. Communication ports allow off-site diagnostics, programming and software updates. By using stock components and locally available maintenance items, the units allow for quick service and minimal down time. Optional overhead sidewall buffer available. 150 psi required. Specify 220V or 440V 3 ph, F.O.B. factory.

Order No.	Mfr. No.	Description	Ship Wt.
31054	ATB40	Truck Tire Buffer	4,500 lbs. - 1,935 kg
31056	ATB50	Truck Tire Buffer	5,000 lbs. - 2,272 kg

Buffer Exhaust Hose

- Remove hazardous dust from tire buffing operations
- Other hose diameters & lengths available contact us



Available in 12' and 25' lengths, 8" in diameter. 8" hose clamps also available. Order as required.

Order No.	Description	Ship Wt.
31045	12' x 8" Diameter Buffer Exhaust Hose	17 lbs. - 8 kg
31046	25' x 8" Diameter Buffer Exhaust Hose	33 lbs. - 15 kg
31040	8" Hose Clamp	

Exhaust Blower

- Heavy-Duty 7.5 hp blower removes buffing dust efficiently
- Other sizes available, contact us



A heavy-duty, spark resistant dust removal blower widely used in the industry to collect and transport rubber buffing dust. Extra long life components for minimal up costs and reliable operation.

Order No.	Description
31038	7.5 HP Blower

Inflatable Hub Gauge



Use to check inflation pressure that is being maintained when tires are inflated on expandable hubs. Inflate an old bias casing and insert the gauge into the casing. If pressure is incorrect, adjust the regulator accordingly. Ideal pressure is 23 to 24 lbs.

Order No.	Mfr. No.	Description	Ship Wt.
56102	17400	Inflatable Hub Gauge	2 lbs. - 1 kg
56103	17402	Replacement Needle	1 lbs. - 1 kg

Buffing Templates



Use to check buffing templates on the buffer and are used with buffers having no templates. Complete set of 5 templates to check standard size buffing radius from 12-14, 16-18, 20-22, 24-26 and 28-30. Contact us for other sizes.

Order No.	Description	Ship Wt.
31011	Buffing Templates	2 lbs. - 1 kg

Buffing Hood Brushes



Assists in the collection of buffing dust by surrounding the buffing hood assembly. When the tire is in the buffing process, the brush is in contact with the tire deflecting the rubber dust back into the collection system.

Order No.	Description	Length	Bristle	Ship Wt.
94405	Tampico Hood Brush	6'	1 1/2"	6 lbs. - 3 kg
94406	Tampico Hood Brush	6'	2"	6 lbs. - 3 kg
94407	Tampico Hood Brush	6'	3"	6 lbs. - 3 kg
94408	Black Nylon Hood Brush	6'	1 1/2"	6 lbs. - 3 kg
94409	Black Nylon Hood Brush	6'	2"	6 lbs. - 3 kg
94410	Black Nylon Hood Brush	6'	3"	6 lbs. - 3 kg
94413	Tampico Hood Brush	1'	1 1/2"	1 lbs. - 1 kg
94414	Tampico Hood Brush	1'	2"	1 lbs. - 1 kg
94415	Tampico Hood Brush	1'	3"	1 lbs. - 1 kg
94416	Black Nylon Hood Brush	1'	1 1/2"	1 lbs. - 1 kg
94417	Black Nylon Hood Brush	1'	2"	1 lbs. - 1 kg
94418	Black Nylon Hood Brush	1'	3"	1 lbs. - 1 kg

Buffing Hood Brush Holders



Older style brush holders must be drilled in the brush for mounting to the buffer every time it needs replaced. New style brush holders only have to be drilled and installed once. The used brush can be slid out and a new one in.

Order No.	Description	Length	Ship Wt.
94411	Aluminum Brush Holder	6'	6 lbs. - 3 kg
94412	Aluminum Brush Holder	1'	1 lbs. - 1 kg

Expandable Rim Reconditioning Service Available

- Core trade-ins welcomed
- Reconditioned expandable hubs available
- One-Year limited warranty



CRS Expandable Rim Assemblies & Replacement Belts

- More expandable rim sizes available, contact us



Use Myers Tire and Tube Mounting Compound (46632) to extend belt life.

Expandable Rims Complete

Replacement Belts

Order No.	Rim Size	Bead Width	Order No.
31533	12" - 14"	5"	31573
31534	13" - 16"	5"	31574
31031	13" - 16"	6 3/8"	31575
31537	13" - 16"	11 3/8"	31576
31538	14" - 17"	6"	31577
31536	14" - 17"	7 1/8"	31578
31539	14" - 17"	9 1/4"	31579
31565	14" - 17"	11 3/8"	31580
31033	17" - 20"	6 1/2"	31581
31566	17" - 20"	8 1/4"	31582
31563	18" - 20"	7 3/8"	31572
31508	17" - 20"	13 1/4"	31583
31035	20" - 22.5"	7 1/2"	31585
31107	20" - 22.5"	8 1/4"	31625
31055	20" - 22.5"	9"	31586
31108	20" - 22.5"	11 3/4"	31587
31037	22" - 24.5"	7 1/2"	31588
31110	22" - 24.5"	8 1/4"	31626
31540	22" - 24.5"	9"	31589
31569	22" - 24.5"	13 3/8"	31590
31057	23" - 25"	13 3/8"	31590
31058	23" - 25"	18 1/2"	31627

NATIONAL Expanding Hub Lubricant

Use to lubricate expandable hubs, pistons and stems.



Order No.	Mfr. No.	Description
31552	R733001	National Expanding Hub Lubricant 10 Oz.

Heavy-Duty Garter Spring for AZ Extruder

Heavy-duty .255 diameter spring holds the heavy brass stems in place on the AZ Extruder expandable hub.

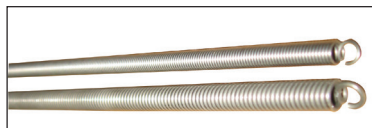

Order No.	Description
31030	Heavy-Duty Garter Spring for AZ Extruder

Brass Hub Stems

- For use on AZ cushion gum extruder/tread builders



The brass hub stems are designed to withstand the higher pressure the extruder head puts on the tire in the expandable hub. Prevents leading edge wear and are guaranteed not to bend. Hubs require 12 locking stems. Sold in sets of 12.

Order No.	Description	Ship Wt.
31048	Brass Hub Stems	21 lbs. - 10 kg

Expandable Hub Rebuild Kit

Everything required to rebuild expandable hubs in the shop. Includes 8 Myers plain stems, 4 Myers locking stems, garter spring, O-Ring kit, (2) brass bushings, and a can of dry lubricant.



Order No.	Description	Ship Wt.
31599	Rebuild Kit for Expandable Hubs Includes Brass Bushings 31597, 31598	7 lbs. - 3 kg

Individual Expandable Hub Replacement Parts

Order No.	Description
31032	Myers Plain Stem - 8 Required - Sold Each
31034	Myers Locking Stem - 4 Required - Sold Each
31138	National Plain Stem Sold Each (8) Required
31139	National Locking Stem Sold Each (4) Required
31036	Garter Spring
31030	AZ Extruder Heavy-Duty Garter Spring
31596	Dry Lubricant for Expandable Hubs 11 Oz. Teflon
31595	O-Ring Kit for Expandable Hubs
31598	Brass Bushing for Main Shaft
5473225	112C Safety Valves Specify (Set at 25 psi) 1/4" MPT
31597	Brass Bushing for Piston (Front)

Expandable Hub Rebuild Kit for MRT Shops

- All locking stems stabilize the hub & tire assembly for a more accurate buff



Rebuild expandable hubs in the shop. Includes (12) locking stems, garter spring, O-Ring kit, and (2) brass bushings.

Order No.	Description	Ship Wt.
31605	Rebuild Kit for Expandable Hubs w/ CRS All Locking Stems	7 lbs. - 3 kg

Expandable Hub Rebuild Kit for Bandag Shops

- Authentic National locking & plain stems & National lube



Rebuild expandable hubs in the shop. Includes (12) locking stems, garter spring, O-Ring kit, (2) brass bushings, and a can of National Expanding Hub Lubricant.

Order No.	Description	Ship Wt.
	Rebuild Kit for Expandable Hubs w/ Bandag All Locking Stems & National Spray Lube	7 lbs. - 3 kg
31138	National Plain Stems Sold Each (8) Required	
31139	National Locking Stems Sold Each (4) Required	

Cup Cutters

OTR Carbide Tipped Delugger Blades



Used on Lodi and Salisbury machinery. Delugger, Buffer 14 blades required per fill.

Order No.	Mfr. No.	Description
43949	47547	Carbide Tipped Blades

OTR Delugger-Buffer Cup Cutter



- Contact us for other OTR cup cutters
- For use on Saico OTR buffers



Order No.	Mfr. No.	Description	Ship Wt.
31549	943	5" Diameter Repl. Cup Cutter	2 lbs. - 1 kg
31548	942	4" Diameter Repl. Cup Cutter	2 lbs. - 1 kg
31547	32A60	Sharpening Stone	2 lbs. - 1 kg

Detreader Cup Cutter



- For use on Akron detreader buffer only



Order No.	Mfr. No.	Description	Ship Wt.
31550	942	4" Serrated Cup Cutter	2 lbs. - 1 kg
31551	A46N	Sharpening Stone	1 lbs. - 1 kg

Circumference-Diameter Tape with Claw

Easy-to-read raised markings in natural steel over black background. Brown leather case. One side in feet; inches and 8ths. Other side diameter equivalents of circumference in diameter feet and inches. Length: 33' feet, claw hook.



Order No.	Mfr. No.	Description	Ship Wt.
46740	261PTH	33' Circumference Diameter Tape with Claw	2 lbs. - 1 kg
46747	261PTH-1	Refill	2 lbs. - 1 kg
46739	263PTH	50' Circumference Diameter Tape with Claw	2 lbs. - 1 kg
46724	C106TPM	6.5m Metric Circumference Diameter Tape with Claw	2 lbs. - 1 kg

R.M.A. Buffing Texture Pad



Various buffing textures are required for retreading and repair procedures. The rubber pad has the 6 standard textures molded into it. Includes R.M.A. bulletin #29.

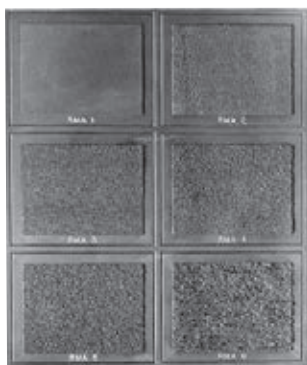

Order No.	Description
18400	RMA Buffing Texture Pad

Sharpening Stones for Buffers



Compatible for many Bandag buffers

Order No.	Description	Ship Wt.
42159	Sharpening Stones - Pair	2 lbs. - 1 kg

Replacement Cartridge for B&J Rasp Sharpener

For use with all B&J rasp sharpening attachments.

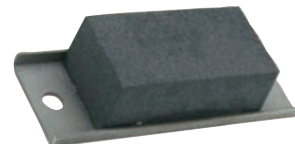

Order No.	Mfr. No.	Description
31078	19200	Replacement Cartridge

B&J R-115 Reg HD Mulching Rasp Hub



- Use for buffing scrap tires & turning buff scraps into black, bark-like ground cover mulch
- For best results use a mulching buffer



"Mulcher" buffer rasp hubs usually run at slower speeds and a slower tire revolving speed.

Order No.	Mfr. No.	Description	Ship Wt.
43898	12-800-3	R-115 Reg HD Rasp 8" Wide	25 lbs. - 11 kg
43899	12-800-4	R-115 Reg HD Rasp 10" Wide	26 lbs. - 12 kg
43900	12-800-5	R-115 Reg HD Rasp 12" Wide	27 lbs. - 12 kg
43518	11-210	Patriot M1 Mulching Blades Set of 30	

B&J OTR Detreader Buffing Blade



- Used on the outside row of a B&J R115 buffing rasp hub



Designed to work only with cross-cut type buffing heads. The "bent" detreader blade does the heavy cutting while the regular R115-20 blades texturize the buff surface. Primarily used in OTR applications.

Order No.	Mfr. No.	Description
43885	R-115-16	OTR Detreader Buffing Blade

Disposable Dust/Mist Masks

Inexpensive, adjustable nose bridge, ribbed designs, molds to facial contours, large filter area. NIOSH and MSHA approved for coal, cadmium, lead, cotton dust, silica and more. Approved for a PEL not less than .05 mg/m3, OSHA up to 10 x PEL. NIOSH/MSHA TC-21C-132



Order No.	Mfg. No.	Std. Pkg.
45545	07048/8210	Sold Each

Disposable Filter Masks

Nuisance dust mask. Use for comfort only - not for lung protection. Provides relief against the irritating effects of such nuisance dusts as pollen, common house dust, salt and cut grass.



Order No.	Mfg. No.	Std. Pkg.
45546	1501	50

B&J Refill Buffing Blades

- For R2, R3, R4 & R115 rasp hubs

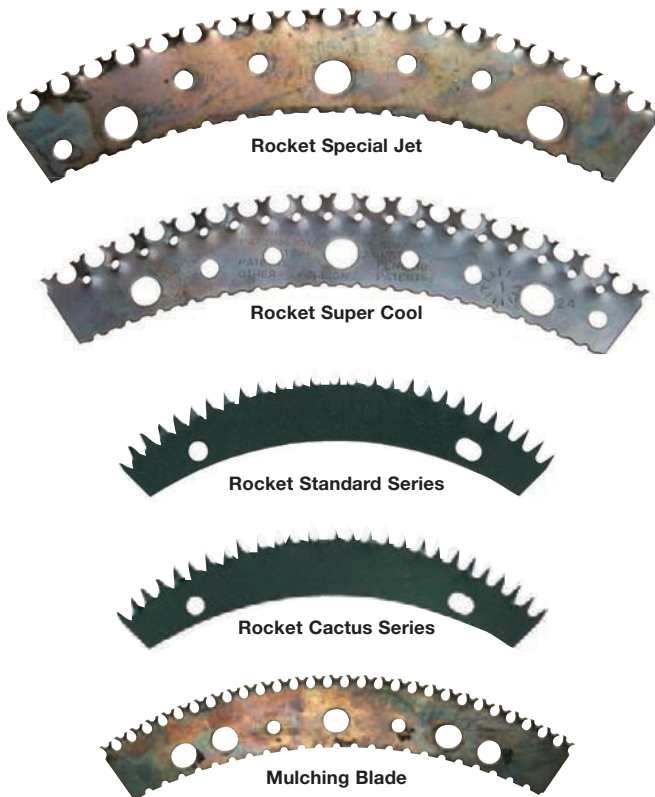

There are three types of B&J Rocket Refills or blades. Old-style Standard and Cactus, and the newer Jet series. The designs of the cutting teeth vary and are a matter of customer choice. We recommend the Jet series as they are generally the longest lasting, fastest and smoothest buffing blade. **Note:** All packaged 50 sets per case.

Order No.	Mfr. No.	Type	Per Set
43865	R-2	Standard	40
43868	R-3-24	Regular Jet	28
43863	R-4	Cactus	28
43808	R-4-20	Special Jet	28
43872	R-4-24	Regular Jet	28
43873	R-4-25	Special Jet	28
43874	R-4-16	Special Jet	28
43876	R-105-22	Regular Jet	35
43879	R-115-25	Special Jet	25
43911	R-115-25	Super Cool	25
43883	R-115-20	Special Jet	25
43909	R-115-20	Super Cool	25
43884	R-115-16	Special Jet	25
43518	M1	Patriot Mulching Blade	25
43956	R-115-20	Switch Blade	25

B&J Outer Support Spacers for Rocket R4 Rasp Hubs

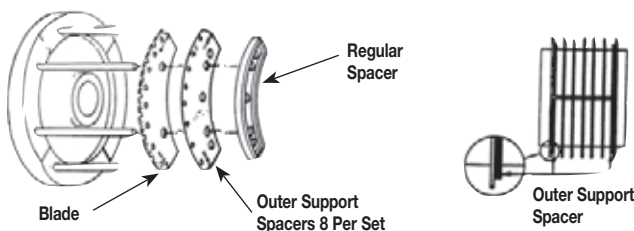

Order No.	Mfr. No.	Type	Per Set
43819	16-624	R4 Domestic	8

B&J Replacement Spacers for R3, R4 & R115 Rasp Hubs



I-Beam aluminum spacers available in $\frac{3}{16}$ ", $\frac{1}{4}$ ", and $\frac{3}{8}$ ". Note: For optimum performance replace spacers and pins as a set.

Order No.	Hub Type	Spacer Width
43850	R3	$\frac{3}{16}$ "
43851	R3	$\frac{1}{4}$ "
43852	R3	$\frac{3}{8}$ "
43853	R4	$\frac{3}{16}$ "
43854	R4	$\frac{1}{4}$ "

Order No.	Hub Type	Spacer Width
43855	R4	$\frac{3}{8}$ "
43856	R115	$\frac{3}{16}$ "
43857	R115	$\frac{1}{4}$ "
43858	R115	$\frac{3}{8}$ "

B&J Air-Cooled Spacers for R115 Rasp Hubs



Specially configured thin spacers allow air to flow between the buffing blades for longer service.

Order No.	Description
43823	R115 $\frac{3}{8}$ " Air-Cooled Spacer
43824	R115 $\frac{1}{4}$ " Air-Cooled Spacer

B&J Alu I-Beam Air-Cooled Spacers



- Air-Cooled spacers provide ventilation increasing rasp life
- For R115 rasp hubs
- Complete line available for all rasp hubs

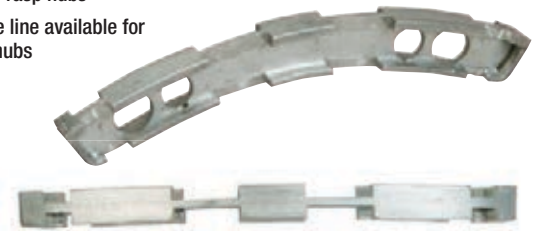

Order No.	Mfr. No.	Description	Pinhole
43818	111468	R115 Alum $\frac{3}{8}$ " I-Beam Air Spacer	8.7mm
43820	111469	R115 Alum $\frac{1}{4}$ " I-Beam Air Spacer	8.7mm
43797	111450	R4 Alum $\frac{3}{8}$ " I-Beam Air Spacer	8.7mm
43798	111451	R4 Alum $\frac{1}{4}$ " I-Beam Air Spacer	8.7mm
43799	111471	R115 CONVEX Alum $\frac{3}{8}$ " I-Beam Air Spacer	9.15mm
43800	111472	R115 CONVEX Alum $\frac{1}{4}$ " I-Beam Air Spacer	9.15mm

B&J Replacement Pins for Rasp Hubs



- Convex-Style hubs must be returned to the factory for convex pin replacement



- Other lengths available, contact us



Order No.	Dia.	Length	Order No.	Dia.	Length	Order No.	Dia.	Length
43934	$\frac{5}{16}$ "	2 $\frac{1}{2}$ "	43942	$\frac{5}{16}$ "	4 $\frac{1}{2}$ "	43833	$\frac{5}{16}$ "	12"
43935	$\frac{5}{16}$ "	3"	43943	$\frac{5}{16}$ "	5"	43813	$\frac{1}{4}$ "	3"
43936	$\frac{5}{16}$ "	3 $\frac{1}{8}$ "	43944	$\frac{5}{16}$ "	5 $\frac{3}{8}$ "	43812	$\frac{1}{4}$ "	3 $\frac{3}{8}$ "
43937	$\frac{5}{16}$ "	3 $\frac{1}{4}$ "	43945	$\frac{5}{16}$ "	6"	43897	$\frac{1}{4}$ "	3 $\frac{3}{4}$ "
43938	$\frac{5}{16}$ "	3 $\frac{3}{8}$ "	43946	$\frac{5}{16}$ "	6 $\frac{1}{2}$ "	43814	$\frac{1}{4}$ "	4"
43939	$\frac{5}{16}$ "	3 $\frac{1}{2}$ "	43831	$\frac{5}{16}$ "	8"	43811	$\frac{1}{4}$ "	6"
43940	$\frac{5}{16}$ "	3 $\frac{3}{4}$ "	43832	$\frac{5}{16}$ "	10"	43815	$\frac{1}{4}$ "	8"
43941	$\frac{5}{16}$ "	4"						

Buffing Rasps

B&J Refill Buffing Blades for Eagle, Saturn & Duro-Max Rasp Hubs



Apollo II (43912)



Apollo III (43914)



Eagle II Refill



Special Rocket Jet (43921)



Duro-Max

Rocket Saturn rasps are proven to be the fastest cutting, longest lasting rasps with the best texture for all tire buffing operations. Apollo refills have been tested under all conditions and used on all types of tire buffing equipment with outstanding results. Gemini II blade can be used in existing Saturn II or R4 hub assemblies.

Order No.	Description	Type	Blades Per Set
43912	Apollo II	Refill	28
43922	Apollo II	Detreader	8
43914	Apollo III	Refill	30
43920	S115-25	Refill	30
43921	S115-20	Refill	30
43928	Patriot II	Refill	28
43840	Gemini II	Refill	28
43839	Eagle II	Refill	28
43913	Duro-Max III	Refill	30

50 sets per case.

B&J Replacement Spacers for Eagle II Rasp Hubs



Order No.	Mfr. No.	Description	Spacer Width
43507	16-575	Eagle II Spacer	3/16"
43508	16-574	Eagle II	1/4"
43506	16-576	Eagle II Spacer (Standard) 24 Per Set	3/8"

B&J Outer Support Spacers for Saturn II Hubs

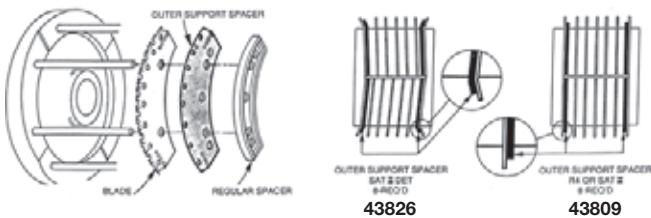

Rasp hubs on Bandag buffers ordered from factory include 43809 support spacers.

Order No.	Mfr. No.	Description	Per Set
43809	16630	For Use with Apollo II Blades (BANDAG O.E.M.)	8
43826	16626	For Use with Apollo II Detreader Blades	8

B&J Replacement Spacers for Saturn & Duro-Max Rasp Hubs



43844

I-Beam aluminum spacers available in 3/16", 1/4" and 3/8".
Note: For optimum performance replace spacers and pins as a set.

Order No.	Hub Type	Spacer Width	Order No.	Hub Type	Spacer Width
43844	Saturn II	3/16"	43847	Saturn III, Duro-Max III	3/16"
43845	Saturn II	1/4"	43848	Saturn III, Duro-Max III	1/4"
43846	Saturn II	3/8"	43849	Saturn III, Duro-Max III	3/8"

B&J Alu I-Beam Air-Cooled Spacers



- Air-Cooled spacers provide ventilation increasing rasp life
- For Saturn II & III Rasp Hubs & Eagle II Rasp Hubs



Order No.	Mfr. No.	Description	Pinhole
43790	111462	SAT III Alum 3/8" I-Beam Air Spacer	8.7mm
43791	111463	SAT III Alum 1/4" I-Beam Air Spacer	8.7mm
43792	111456	SAT II Alum 3/8" I-Beam Air Spacer	8.7mm
43793	111457	SAT II Alum 1/4" I-Beam Air Spacer	8.7mm
43794	111480	Eagle II Alum 3/8" I-Beam Air Spacer	8.7mm
43795	111481	Eagle II Alum 1/4" I-Beam Air Spacer	8.7mm
43801	111465	SAT III CONVEX Alum 3/8" I-Beam Air Spacer	9.15mm
43802	111466	SAT III CONVEX Alum 1/4" I-Beam Air Spacer	9.15mm
43803	111474	Duro-Max III CONVEX Alum 3/8" I-Beam Air Spacer	9.15mm
43804	111475	Duro-Max III CONVEX Alum 1/4" I-Beam Air Spacer	9.15mm

B&J Air-Cooled Spacers for Saturn III Rasp Hubs



Specially configured thin spacers allow air to flow between the buffing blades for longer service.

Order No.	Description
43825	SAT III 1/4" Air-Cooled Spacer
43830	SAT III 3/8" Air-Cooled Spacer

B&J Replacement Pins for Rasp Hubs



- 5/16" Diameter pins for Eagle II, Duro-Max III & Saturn II & III Hubs

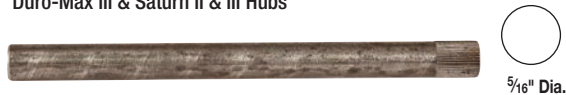

5/16" Dia.

Specify length and rasp in which pins are to be used.

Order No.	Diameter	Length	Order No.	Diameter	Length
43934	5/16"	2 1/2"	43942	5/16"	4 1/2"
43935	5/16"	3"	43943	5/16"	5"
43936	5/16"	3 1/8"	43944	5/16"	5 3/4"
43937	5/16"	3 1/4"	43945	5/16"	6"
43938	5/16"	3 3/8"	43946	5/16"	6 1/2"
43939	5/16"	3 1/2"	43831	5/16"	8"
43940	5/16"	3 3/4"	43832	5/16"	10"
43941	5/16"	4"	43833	5/16"	12"

B&J Convex Rasp Hub & Refill Blades for Mateuzzi Buffers



Convex rasp hub for use with Matteuzzi RAS98E and RAS90 buffers. Includes (45) 43857 1/4" spacers, and R115-20 or R115-25 refill buffing blades. Specify blade refill type. **Factory rasp hub rebuild service available.**

Order No.	Mfr. No.	Description	Ship Wt.
43901	12-809	R115 REG Convex Rasp Hub w/R115-20 or R115-25 Blades-Specify	18 lbs. - 8 kg
43883		R115-20 Refill Buffing Blades Set of 25	
43879		R115-25 Refill Buffing Blade Set of 25	
43857		R115 1/4" Spacers 45 Req	

B&J Rasp Hub & Refill Blades for MRT System



Designed for use in Michelin Retread Plants using the SIO RA2DC and RA2EC cross cut buffers. Includes (26) 43858 3/8" spacers, (8) 43856 3/16" spacers, (1) 3/8" HD spacer, and R115-20 or R115-25 refill buffing blades. Specify blade refill type. **Factory rasp hub rebuild service available.**

Order No.	Mfr. No.	Description	Ship Wt.
43827	12-843-1	R115NS HD Rasp Hub w/R115-20 or R115-25 Blades-Specify	18 lbs. - 8 kg
43883		R115-20 Refill Buffing Blades Set of 25	
43879		R115-25 Refill Buffing Blades Set of 25	
43856		R115 3/16" Spacers 8 Req-	
43858		R115 3/8" Spacers 26 Req-	

B&J Eagle II Rasp Hub & Refill Blades

- Compatible for use on Bandag buffers



Compatible for use with Bandag buffer models 8110, 8120, 8200, and 8400. Includes (24) 43506 3/8" Eagle-type spacers and 43839 Eagle II refill buffing blades. **Factory rasp hub rebuild service available.**

Order No.	Mfr. No.	Description	Ship Wt.
43505	12-900	Eagle II 8" Dia., 4" with, 1 1/2" A.H.	17 lbs. - 8 kg
43839		Eagle II Refill Buffing Blades Set of 28	
43506	16-576	Eagle II 3/8" Spacers 24 Req	

B&J Saturn II Rasp Hub & Refill Blades

- Includes 1 set 43922 Detreader blades
- Compatible for use on Bandag buffers



Designed for use with buffer models, 8110, 8120, 8200, and 8400. Includes (20) 43846 3/8" spacers, (4) 43844 3/16" spacers, (8) 43922 Detreader blades, and 43912 Apollo II refill buffing blades. **Factory rasp hub rebuild service available.**

Order No.	Mfr. No.	Description
43516	12-942	Replacement SATII Rasp Hub w/Apollo II or R-4 Blades-Specify
43517	12-921-1	OEM Sat II Hud w/Apollo II Blades & 43809 Support Spacers
43912		Apollo II Refill Buffing Blades Set of 28
43809		Saturn II Outer Support Spacer (Factory) 8 Req
43922		Replacement Detreader Blades 8 Req
43846		Saturn II 3/8" Spacers 20 Req
43844		Saturn II 3/16" Spacers 4 Req

B&J Duro-Max III Rasp Hub & Refill Blades for Mateuzzi Buffers



Convex rasp hub is designed for use with Matteuzzi RAS98E or RAS90 buffers. Includes (54) 43848 1/4" spacers and 43913 Duro-Max III refill buffing blades. **Factory rasp hub rebuild service available.**

Order No.	Mfr. No.	Description	Ship Wt.
43915	12-915	DURO MAX III Rasp Hub with DURO MAX III Blades	19 lbs. - 9 kg
43913		DURO MAX III Refill Buffing Blades Set of 30	
43848	16-909	Saturn III 1/4" Spacers 54 Req	

B&J Saturn III Rasp Hub & Refill Blades



Convex rasp hub used on Marangoni Leonardo buffers. Includes (2) sets of Apollo III blades, (54) Saturn 1/4" spacers and (21) keyways. **Factory rasp hub rebuild service available.**

Order No.	Mfr. No.	Description	Ship Wt.
43947		Saturn III Rasp Hub	19 lbs. - 9 kg
43914		Apollo III Refill Buffing Blades	
43848		Saturn II 1/4" Spacers - 54 Required	

B&J Flat Rasp Hub & Refill Blades for Matteuzzi Buffers

- Flat rasp hub for use on Matteuzzi RAS98E Ultra Buffers



Order No.	Mfr. No.	Description	Ship Wt.
43895	12-809-3	R115 REG Flat Rasp Hub with R115-20 or 115-25 Blades. Specify	18 lbs. - 8 kg
43883		R115-20 Refill Buffing Blades Set of 25	
43879		R115-25 Refill Buffing Blades Set of 25	
43857		R115 1/4" Spacers 45 Required	

How To Order B&J Buffing Hubs

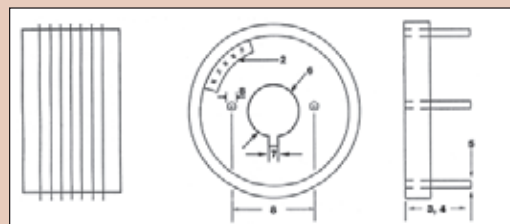

Specify

1. Buffer model number
2. Buffing hub type. See hub types below
3. Pins, straight or convex
4. Width - full length of pin & pin diameter
5. Arbor Hole
6. If required - Keyway size & number of keyways needed. (1 or 2)
7. If required - drive pin hole diameter & center-to-center hole dimension
8. Rasp blade type

HUB TYPES AVAILABLE

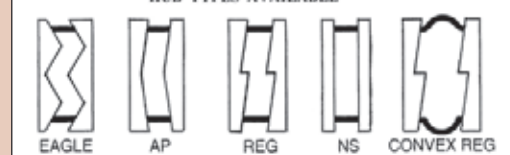

RUBBERHOG Contour Wheel

- Compatible for use on Bandag buffers

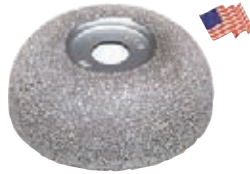

A contour wheel compatible for Bandag sidewall buffing attachments.

Order No.	Mfr. Code	Diameter	Width	Bore	SSG
42768	129-P	4"	1 1/2"	3/4"	390

RUBBERHOG Donut Wheel for Matteuzzi Buffers

- Reducer bushings available



For Matteuzzi RAS90, RAS98E, RAS98E Ultima and other sidewall buffing attachments. Special bushings required.

Order No.	Mfr. Code	Diameter	Width	Bore	SSG
42774	708	6"	1"	1 1/2"	390

Airless Sprayer for Patch Rubber Water Base Cement

A high production sprayer. Equipped with a reciprocating air motor, 5 gallon stainless steel tank and a filter regulator. Max. working pressure 110 psi.



Order No.	Mfr. No.	Description	Ship Wt.
56287	SPU	Sprayer Unit Complete	140 lbs. - 63 kg
56289	111884M	Filter Screen	1 lbs. - 1 kg
56291	112035M	Gasket	2 lbs. - 1 kg

GRACO MONARK Airless Hydra-Sprayer

- Prevents air contamination of cement
- 5-Gallon capacity

Lightweight, portable, quality airless spray unit. Supplies two spray guns under most operating conditions. Delivers 3/4 gal. per min. Operating pressure 20-120 psi. Includes agitator, 23:1 ratio pump, air regulator with gauge, air valve, tip clean out valve, instant-latch pail cover, 25' nylon spray hose, spray gun with swivel and .015" orifice. 5 gallon capacity.



Order No.	Mfr. No.	Description	Ship Wt.
56214	232-437	Monark Hydra-Spray	39 lbs. - 18 kg
56190	235-462	Repl. Spray Gun - No Tip	2 lbs. - 1 kg
56189	163-415	Repl. Tip Only for Spray Gun	1 lbs. - 1 kg
Optional Reverse-A-Clean Upgrade			
56188	237-859	Guard	
56213	221-415	Tip	

Tire Stippling Brushes

46011



Order No.	Mfr. No.	Description
46011	KTD-10	1 1/2" Diameter Brush
46013	KTD-14	2" Diameter Brush

Wire Wheel Brushes

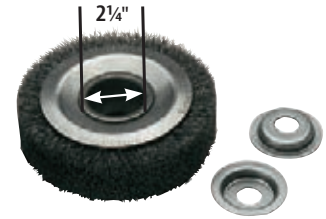

Patented carbon steel wire will not break off, separate, or heat up and scorch rubber or cord. All .010 wire, 2 1/4" arbor hole.

Order No.	Mfr. Code	Dia.	Arbor Hole	Face Width	Description
42002D	432	4 1/4"	3/4"	1"	Compatible with Bandag Sidewall Buffers
42003M21**	632	6"	21mm	1"	For Use on Matteuzzi RAS90 & RAS98E Ultra
42003M38***	632	6"	38mm	1"	For Use on Matteuzzi RAS98E

Sidewall Buffing Brush

- Compatible for use on 8400 series Bandag buffers

Compatible for 8400 Bandag series buffing attachment. 1 1/2" wide x 8" with a 2" arbor hole.



Order No.	Description
42035	8" Sidewall Brush

Cement Dispensers



Keeps usable quantities of cement air tight and clean. Air tight screw cap with brush mounted in lid prevents contamination and evaporation. Bristles are 2" long. Use different color cans for different type cements, a can with a black lid for one cement and a can with a blue lid for the other.

Order No.	Description	Capacity
84025	Aluminum Dispenser with Black Lid	1 qt.
84023	Aluminum Dispenser with Blue Lid	1 qt.
Replacement Lid and Brush Assembly		
84029	Black Lid & Brush Only	1 qt.
84029B	Blue Lid & Brush Only	1 qt.

Spray Booths

- Call Myers Tire Supply for details

Lighting

- High efficiency Class 1, Division 2 fluorescent fixtures (tubes not included)
- Lights are UL and CSA approved

Filtration

- Your choice of filtration media, pads or rolls

Multiple Configurations

- Flexible top or rear exhaust outlet - no additional parts required

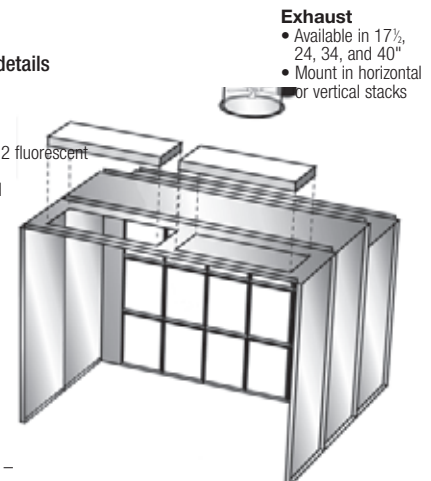

Cement spray booth for passenger and truck tires. Wide work area with power exhaust to prevent fume build-up and remove overspray. Includes explosion-proof motor, light and 24" diameter top stack. Inside dimensions: 6'W x 8'H x 6'D; outside dimensions 6'4"W x 8'2"H x 6'8"D. Recommended accessories include exhaust stack with automatic damper and connector ring fan to stack. Shipped un-assembled.

VULCAN-VULCAP Tread Builder/ Stitcher

Build, stitch, and install envelopes, all on one piece of equipment. Automatic two stage stitching, rolls cushion gum at 30 psi and tread rubber at 90 psi. Forward-reverse foot control for tire building. Handles from 13" through 25" rim diameters. Requires 125 psi, 1/2" air line. 5 1/2' x 3' x 5' high. No electric power required. Includes expandable hub; 15" super single treadcutter; Hi-Lo stitch control; cushion gum support and drain filter. See page 302 for expandable rim assemblies not included with builders.



Order No.	Mfr. No.	Description	Ship Wt.
37022	TR106	Builder w/ Guillotine Cutter	700 lbs. - 315 kg
36977	1004404	Repl. Teflon Cutter Strip 13 1/2" Long	1 lbs. - 1 kg
36979	1060303	Repl. Teflon Cutter Strip 15" Long	1 lbs. - 1 kg
34773	1004502	13" Blade	2 lbs. - 1 kg
36594	1060302	15" Blade	

L.R. OLIVER Rotary Knife



For cutting precured tread. Carbide coated sides. Not regritable.

Order No.	Mfr. No.	Diameter	Arbor	Builder Application
42756	RH100-GE-138	6"	1 3/8"	Cahill R-23 & TR-36
42754	RH100-GEG-134	6"	1 3/4"	Salisbury & Oliver
42773	RH100-GE-200	6"	2"	Compatible with Bandag 5110 Builder, Matteuzzi RAS400, RAS401, RAS505, RAS201
Special 80 Grit				
42748	RH100-GEG-134-80	6"	1 3/4"	Salisbury & Oliver
42749	RH100-GE-138-80	6"	1 3/8"	Cahill R-23 & TR-36
42750	RH100-GE-200-80	6"	2"	Compatible with Bandag 5110 Builder, Matteuzzi RAS400, RAS401, RAS505, RAS201

Tungsten Carbide Tread Cutting Blades



For cutting precured tread. Carbide coated sides. Regritable.

Order No.	Fits	Diameter	Width	Arbor Hole	Grit
42702	Cahill R23 & TR36, Shaw Almex	6"	1/8"	1 3/8"	100
42703	Oliver/Salisbury/	6"	1/8"	1 3/4"	100
42704	Compatible with Bandag 5110 Builder, Matteuzzi, RAS400, RAS401, RAS505, RAS201	6"	1/8"	2"	100

DUO-FAST Stapler



Heavy-duty manual stapler.

Order No.	Mfr. No.	Description	Crown	Per Box	Ship Wt.
45748	CSS000	Heavy-Duty Stapler			3 lbs. - 1 kg
45758	ED5008C-06	1/4" Staples Length Fasco	1/2"	5,000	2 lbs. - 1 kg
45754	ED5010C-08M	5/16" Staples Length Fasco	1/2"	5,000	2 lbs. - 1 kg
45756	ED5012C-10	3/8" Staples Length Fasco	1/2"	5,000	2 lbs. - 1 kg
45757	ED5018C-14	7/16" Staples Length Fasco	1/2"	5,000	2 lbs. - 1 kg

Air Stapler

- 1/2" Crown (width)

Lightweight to meet the needs of the retreader. Small profile provides ease of handling with plenty of power. Bottom loading with rear exhaust. Operating pressure is 60 to 100 psi.



45755, 45763

FASCO Stapler & Staples (Duofast Type)

Order No.	Mfr. No.	Description	Crown	Per Box	Ship Wt.
45755	FIB50-16	Air Stapler			3 lbs. - 2 kg
45758	ED508C-06	1/4" Staples Length	1/2"	5,000	2 lbs. - 1 kg
45754	ED5010C-08	5/16" Staple Length	1/2"	5,000	2 lbs. - 1 kg
45756	ED5012C-10	3/8" Staple Length	1/2"	5,000	2 lbs. - 1 kg
45757	ED5018C-14	7/16" Staples Length	1/2"	5,000	2 lbs. - 1 kg

FASCO Stapler & Staples (Bostitch Type)

Order No.	Mfr. No.	Description	Crown	Per Box	Ship Wt.
45763	F1B84-16	Air Stapler			3 lbs. - 2 kg
45761	ESBNK4023-08	5/16" Staples Length	1/2"	10,000	3 lbs. - 2 kg
45759	ESBNK4023-10	3/8" Staples Length	1/2"	10,000	3 lbs. - 2 kg
45752	ESBNK4023-12	1/2" Staples Length	1/2"	10,000	3 lbs. - 2 kg
45753	ESBNK4023-14	5/8" Staples Length	1/2"	10,000	3 lbs. - 2 kg

DUO-FAST Authentic Stapler & Staples



45771

Order No.	Mfr. No.	Description	Crown	Per Box	Ship Wt.
45771	S020	Air Stapler			3 lbs. - 2 kg
45772	S012C	3/8" Staples Length	1/2"	5,000	2 lbs. - 1 kg
45773	S010C	5/16" Staple Length	1/2"	5,000	2 lbs. - 1 kg

BEA Authentic Stapler

Order No.	Mfr. No.	Description	Crown	Per Box	Ship Wt.
45768	BEA	Air Stapler			3 lbs. - 2 kg
45764	EH1808	Fasco 7/16" Staples Length	1/2"	10,000	3 lbs. - 2 kg

BLACK MAGIC Plastic Staples

- No staple removal, plastic staples melt during the retread process
- Eliminates cuts or abrasion marks from staple removal
- Use for tread splices, wick pads & tire tags



45901

45902
45903

Endorsed by major retread manufacturers. Black Magic 16 and 19 gauge composite polymer staples eliminate staples on the shop floor for a cleaner work area. Envelope life will be extended without the catching and abrasion caused by metal staples. The Omer air staplers are fast, light weight and rugged. Both models hold 70 staples and feature a trigger safety reducing the possibility of accidental firing. **NOTE:** Black Magic staples can only be used with recommended Omer air staplers. Stapler and staples are size specific. Order accordingly.

Order No.	Mfr. No.	Description	Crown	Per Box	Ship Wt.
45902	Omer 81P	Air Stapler for 45900 Staples			2 lbs. - 1 kg
45900	S/05-37TR	3/8" Staples Length 19 Gauge	1/2"	5,112	
45903	Omer 82P	Air Stapler for 45901 Staples			2 lbs. - 1 kg
45901	SH/05-55TR	7/16" Staples Length 16 Gauge	1/2"	4,200	

Wicking Materials

Air-Rid Cord

- Releases trapped air between buffed casing & tread rubber



Air-Rid Cord placed between buffed casing and tread rubber continuously releases air that may build up and cause mold blows or prevent firm bond of tread rubber. Length 100 yards.

Order No.	Mfr. No.	Description	Width
56456	AR-12	Full & Top Tread Commercial & Top Cap Truck Tires Thru 1100 x 20	12"
56458	AR-20	For Full Tread Truck Tires	20"

Pli-Vent

Vents air between the precure tread and the envelope. Use with conventional and precure retreading. Releases trapped air from casings of all retreads regardless of size, type or retreading process. Also used to vent air from section repairs and skives.

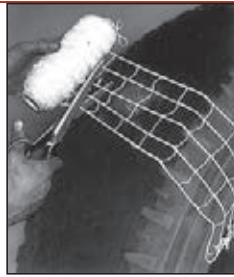

Order No.	Mfr. No.	Description
56450	RPV	100 Yd. Spool, 6" Wide

Buzzout Cord

The cord wicks air from buzzouts and section repairs in bias tires to reduce failures. 200 yards, two 100 yard rolls.

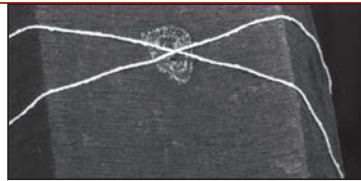

Order No.	Description	Per Roll
56478	Buzzout Cord	200 Yds. (2) 100 Yd. Spools

ROBBINS Wick Pad

- Fabric reinforced rubber

A molded rubber pad with grooves that wicks the air eliminating nylon wicking pads. Molded grooves wicks the air eliminating nylon wicking pads. No poly underneath. Can also be attached to the underside of an envelope using the valve to hold it in place

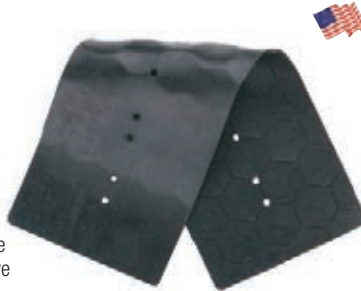

Order No.	Mfr. No.	Description
56060	2025	6" W x 19" L Wicking Pad

ROBBINS Rubber Wick Pad

- Designed for use with inside/outside envelope systems



More durable than cloth wick pads and can be used repeatedly. Does not require poly underneath.

Order No.	Mfr. No.	Description
56061	Size 1	Large Super Single Wick Pad 55½" x 6¾"
56062	Size 2	Medium Truck Wick Pad 48¾" x 6¾"
56063	Size 3	Light Truck Wick Pad 29" x 5"

Poly

- Perforated
- Available in standard, heavy-duty & high temperature



A heat-resistant polypropylene material used for wicking precure treads. Apply between tread and envelope. The choice as to which "poly" to use depends primarily on the temperature of the chamber and the width of the material.

Order No.	Description	Max. Temp.	Rolls Per Box	Feet Per Box	Ship Wt.
15010*	Standard Perf. 12"	280°	1	2,700'	13 lbs. - 6 kg
15028	HD Perf. 12" MTLT	280°	1	2,700'	14 lbs. - 6 kg
15029	HD Perf. 14" MTLT	280°	1	2,700'	16 lbs. - 7 kg
15030	HD Perf. 15" MTLT	280°	1	2,700'	17 lbs. - 8 kg
15031	HD Perf. 18" MTLT	280°	1	2,700'	20 lbs. - 9 kg
15048	HD Perf. 30"	280°	1	2700'	50 lbs. - 34 kg
15020	High Temp. Perf. 12"	330°	1	4000'	19 lbs. - 9 kg
15038	High Temp. Perf. 14"	330°	1	4000'	22 lbs. - 10 kg
15021	High Temp. Perf. 16"	330°	1	4000'	25 lbs. - 11 kg
15039	High Temp. Perf. 18"	330°	1	4000'	28 lbs. - 13 kg

*15010 poly is sold by the pound, price quoted is based on weight per box.

Wicking Pad with Tabs

- Used with inside/outside envelope curing systems
- Overall length 44" including straps



An 8" x 12" stretch wicking pad with a 16½" long x 1½" wide tab sewn to each end. Sold in box quantity only.

Order No.	Description	Qty.	Ship Wt.
56486	8" x 12" Stretch Wicking Pads	24	2 lbs. - 1 kg

Wicking for Precure Treads

- 1-½" Green wicking
- Stretch pads



Order No.	Description	Qty.	Ship Wt.
56485	Green Wicking 1½"	180 Ft. Roll	4 lbs. - 2 kg
56477	Stretch Pads 8" x 12"	24 Per Box	3 lbs. - 2 kg
56481	Stretch Pads 8" x 15"	24 Per Box	4 lbs. - 2 kg
56482	Stretch Pads 8" x 20"	24 Per Box	5 lbs. - 3 kg
56484	Stretch Pads 8" x 48"	24 Per Box	9 lbs. - 4 kg
56470*	60"W x 75' Bulk Wick Material		9 lbs. - 4 kg

* Same material as stretch wick

Staple Pulling Tape

Tape is put over the splice and the staples go through it. Staples are removed by pulling off the tape.



Order No.	Color	Width	Length	Ship Wt.
56471	White	1"	300'	3 lbs. - 2 kg

Envelope Repair Kit

- For permanent repairs to damaged preure envelopes



Repair ripped or hole-damaged curing envelopes and get the maximum amount of cures. The kit includes: 2 rolls of Envelope Repair Gum compounded with similar heat resistant material as envelopes, an 8 oz. can of Envelope Repair Adhesive, 1 quart of Cleaner Fluid and scraper.

ERV Envelope Repair Vulcanizer

Features a large 6" curing head with an air-driven silicone rubber piston pad providing even pressure during the cure cycle. Built-in timer turns off heat and air automatically. Throat depth 14½". Includes bench mount brackets. Available in 110V and 220V.

Order No.	Description	Ship Wt.
14340	Envelope Repair Kit - Includes (2) Rolls of Repair Gum	6 lbs. - 3 kg
36464	ERV Vulcanizer (110V)	60 lbs. - 27 kg
Repair Kit Replacement Materials		
18140	1 Lb. Roll Envelope Repair Gum	2 lbs. - 1 kg
16180	8 Oz. Envelope Repair Adhesive	1 lbs. - 1 kg
16471	1 Qt. Cleaner Fluid	1 lbs. - 1 kg
42620	Innerliner Scraper	1 lbs. - 1 kg

ROBBINS Envelope Repair Kit

Everything needed to repair and extend the life of Robbins envelopes Includes 2 lb. roll of specially formulated envelope cushion gum, cement and instructions



Order No.	Description
41597	Robbins Envelope Repair Kit
36464	ERV Vulcanizer (110V)

BRANICK Envelope Sealer Rings



Adjusting Screw and Clevis Retrofit Kits available. Contact your Myers sales representative.

Heavy-duty Acme threads on the adjusting bolt. Sliding shield on the outer ring body helps prevent pinched envelopes. Ring tabs are the exact length required, not too long to cause punctures.

Packaged and Sold in Pairs					
Order No.	Size	Ship Wt.	Order No.	Size	Ship Wt.
34206	14"	32 lbs. - 15 kg	34202	19.5"	34 lbs. - 16 kg
34207	15"	32 lbs. - 15 kg	34203	20"	34 lbs. - 16 kg
34200	16"	33 lbs. - 15 kg	34212	22"	34 lbs. - 16 kg
34208	16.5"	33 lbs. - 15 kg	34204	22.5"	34 lbs. - 16 kg
34209	17"	33 lbs. - 15 kg	34213	24"	34 lbs. - 16 kg
34201	17.5"	33 lbs. - 15 kg	34205	24.5"	34 lbs. - 16 kg

Curing Rim Road Type with Separate Flanges for Chamber Use

- Most types for passenger & truck tires with positive locking device
- Special order only



Available in passenger, truck, earthmover, and aircraft sizes. High Flange type available in limited sizes.

Order No.	Description
Call to Order	Specify Diameter & Width

Heat Resistant Rim Flaps

- Other sizes available, contact us



Made for preure retreading to protect curing tubes from failure caused by contact with road rims. Flaps are highly resistant to heat and remain soft and pliable even after multiple cures.

Order No.	Mfr. No.	Description	Ship Wt.
15410	16 x 7.1	6.70-15 Thru 9/10/11-15 6.00-9.00-16, 8.00-10.00-16.5	3 lbs. - 1 kg
15411	20 x 8	8.25-20, 10.00-20 9.00-20, 12.00-20, 11.00-20	4 lbs. - 2 kg
15412	22 x 8	10.00-22, 10-22.5 11.00-22, 11-22.5 12.00-22, 12-22.5	6 lbs. - 3 kg
15413	24 x 8	11-24.5, 11.00-24, 12-24.5, 12.00-24, 13.00-24TG, 14.00-24TG	7 lbs. - 3 kg
15414	22.5 x 9	11-22.5	7 lbs. - 3 kg
15415	24.5 x 9	11-24.5	7 lbs. - 3 kg

SURESEAL Envelope Sealer Rings

- Eliminates metal-to-envelope contact
- Extends envelope life



Specially compounded rubber SureSeal envelope sealing rings eliminate metal to envelope contact lengthening envelope life and virtually eliminating tears. The design eliminates sealing ring adjustments. Simply lock and it seals. The conical design of the ring "adapts" to the variations in bead diameters. 22.5. Rings are sold in pairs only.

Order No.	Description	Ship Wt.
34220	XR-22.5 Metal Rings - Sold Per Pair - 2 Pair Per Box	35 lbs. - 16 kg
34221	SR-22.5/22 Rubber Rings - Sold Per Pair - 2 Pair Per Box	30 lbs. - 14 kg
34222	SR-19.5 Rubber Rings - Sold Per Pair - 2 Pair Per Box	30 lbs. - 14 kg
34224	XR-19.5 Metal Rings - Sold Per Pair - 2 Pair Per Box	30 lbs. - 14 kg
34223	SR-24.5 Rubber Rings - Sold Per Pair - 2 Pair Per Box	30 lbs. - 14 kg
34225	XR-24.5 Metal Rings - Sold Per Pair - 2 Pair Per Box	30 lbs. - 14 kg
31002	SR-17.5/17 Rubber Rings - Sold Per Pair - 2 Pair Per Box	
31003	XR-17.5 Metal Rings - Sold Per Pair - 2 Pair Per Box	
31004	SR-20 Rubber Rings - Sold Per Pair - 2 Pair Per Box	
31005	XR-20 Metal Rings - Sold Per Pair - 2 Pair Per Box	

Replacement parts for metal rings

Order No.	Description
34226	Spare Part Kit (2) Pull Pins, (2) Roll Pins, (8) Caps
34227	Pull Pin Pkg. of 5
34228	Vinyl Handle Pkg. of 10
34229	Handle Kit Assembly (1) Pull Pin, (1) Roll Pin, (3) Caps, Vinyl Handle & Handle Assembly

ROBBINS CMT Envelopes by Tire Size



Tire Size	No Valve Module Type Seals Sidewall to Sidewall		With Valve Road Rim Type Seals with Removable Flanges		With Valve Road Rim Type Seals with Extended Hi-Flange		With Valve Rimless System Seals on the Face of Bead	
	Envelope Size	Order No.	Envelope Size	Order No.	Envelope Size	Order No.	Envelope Size	Order No.
195/75R14	2715-16	39803	2715-16	39703	2713-18	39702	2710-21	39700
205/75R14	2715-16	39803	2715-16	39703	2711-20	39701	2913-22	39707
7.00R15	2916-19	39809	2913-22	39707	2913-22	39707	2910-25	39705
7.50R15	3216-22	39818	3216-22	39718	3213-24	39717	3211-27	39716
8.25R15	3517-23	39823	3515-25	39722	3513-27	39721	3511-29	39720
9.00R15 LT/LB	2915-20	39808	2913-22	39707	2911-24	39706	2910-25	39705
9.00T15 TR	3515-25	39822	3513-27	39721	3511-29	39720	N/A	-----
10.00R15 LT/LB	3218-19	39819	3216-22	39718	3213-24	39717	3211-27	39716
10.00R15TR	3816-28	39829	3816-28	39729	3812-31	39727	N/A	-----
31x15.5x15	3513-27	39821	3511-29	39720	N.A.	-----	N.A.	-----
215/70R15	2916-19	39809	2713-18	39702	2916-19	39709	2913-22	39707
215/75R15	2916-19	39809	2916-19	39709	2915-20	39708	2910-25	39705
225/75R15	2916-19	39809	2915-20	39708	2913-22	39707	2910-25	39705
235/75R15	2916-19	39809	2915-20	39708	2913-22	39707	2910-25	39705
255/75R15	3218-19	39819	3216-22	39718	3213-24	39717	3211-27	39716
6.00R16	2916-19	39809	2916-19	39709	2916-19	39709	2913-22	39707
6.50R16	2916-19	39809	2916-19	39709	2915-20	39708	2913-22	39707
7.00R16	3117-18	39813	3115-21	39712	3115-21	39712	3111-24	39710
7.50R16	3218-19	39819	3216-22	39718	3213-24	39717	3211-27	39716
8.25R16	3517-23	39823	3515-25	39722	3513-27	39721	3511-29	39720
9.00R16	3515-25	39822	3513-27	39721	3511-29	39720	3812-32	39727
215/75R16	2916-19	39809	2916-19	39709	2915-20	39708	2910-25	39705
215/85R16	3218-19	39819	3218-19	39719	3216-22	39718	3211-27	39716
225/75R16	2916-19	39809	2916-19	39709	2913-22	39707	2910-25	39705
235/85R16	3218-19	39819	3216-22	39718	3213-24	39717	3211-27	39716
245/75R16	3218-19	39819	3216-22	39718	3213-24	39717	3211-27	39716
265/75R16	3216-22	39818	3216-22	39718	3213-24	39717	3211-27	39716
225/70R16.5	2916-19	39809	2913-22	39707	2913-22	39707	2910-25	39705
10R16.5	3218-19	39819	3216-22	39718	3216-22	39718	3211-27	39716
12R16.5	3513-27	39821	3513-27	39721	3513-27	39721	3511-29	39720
8.00R16.5	2916-19	39809	2916-19	39709	2916-19	39709	2913-22	39707
8.75R16.5	2916-19	39809	2916-19	39709	2915-20	39708	2910-25	39705
9.50R16.5	3218-19	39819	3216-22	39718	3216-22	39718	3211-27	39716
750-17	3218-19	39819	3216-22	39718	3213-24	39717	3211-27	39716
8R17.5	3117-18	39813	3117-18	39713	3115-21	39712	3111-24	39710
9R17.5	3218-19	39819	3517-23	39723	3213-24	39717	3513-27	39721
10R17.5	3519-21	39825	3517-23	39723	3515-25	39722	3511-29	39720
11R17.5	3820-24	39831	3818-26	39730	3816-28	39729	3812-32	39727
215/75R17.5	2916-19	39809	3218-19	39719	2915-20	39708	3213-24	39717
225/75R17.5	3218-19	39819	3218-19	39719	3216-22	39718	3211-27	39716
235/75R17.5	3218-19	39819	3216-22	39718	3216-22	39718	3211-27	39716
245/70R17.5	3218-19	39819	3216-22	39718	3216-22	39718	3211-27	39716
8R19.5	3521-19	39826	3521-19	39726	3519-21	39725	3515-25	39722
9R19.5	3521-19	39826	3519-21	39725	3517-23	39723	3513-27	39721
15R19.5	4419-33	39856	4421-32	39758	4419-33	39756	4413-39	39751
16.5R19.5	4419-33	39856	4419-33	39756	4417-36	39754	*4814-44	39780
18R19.5	4419-33	39856	4415-38	39752	4415-38	39752	*4814-44	39780
225/70R19.5	3218-19	39819	3218-19	39719	3218-19	39719	3213-24	39717
235/70R19.5	3218-19	39819	3218-19	39719	3218-19	39719	3213-24	39717
245/65R19.5	3218-19	39819	3218-19	39719	3218-19	39719	3213-24	39717
245/70R19.5	3521-19	39826	3521-19	39726	3519-21	39725	3513-27	39721
265/70R19.5	3521-19	39826	3519-21	39725	3517-23	39723	3513-27	39721
285/70R19.5	3519-21	39825	3517-23	39723	3515-25	39722	3511-29	39720
305/70R19.5	3822-23	39832	3818-26	39730	3818-26	39730	3812-32	39727
445/65R19.5	4419-33	39856	4415-38	39752	4415-38	39752	4513-44	39761
6.50R20	3521-19	39826	3521-19	39726	3521-19	39726	3515-25	39722
7.00R20	3521-19	39826	3521-19	39726	3519-21	39725	3515-25	39722

*4814-44 Envelope Is A Robbins Accu-Fit Brand Envelope

All suggested envelope selections are to be used as a guide only. Variations in tire sizes, tire dimensions, precure tread designs, and precure tread thickness may require a smaller or larger envelope size. In some instances it may be necessary to measure the built tire to determine the correct envelope size. Capacities and specifications are subject to change without notice.



ROBBINS CMT Envelopes by Tire Size

Tire Size	No Valve Module Type Seals Sidewall to Sidewall		With Valve Road Rim Type Seals with Removable Flanges		With Valve Road Rim Type Seals with Extended Hi-Flange		With Valve Rimless System Seals on the Face of Bead	
	Envelope Size	Order No.	Envelope Size	Order No.	Envelope Size	Order No.	Envelope Size	Order No.
7.50R20	3822-23	39832	3822-23	39732	3822-23	39732	3816-28	39729
8.25R20	3822-23	39832	3820-24	39731	3818-26	39730	3812-32	39727
9.00R20	4022-25	39838	4020-26	39737	4018-27	39736	4012-34	39733
10.00R20	4220-28	39846	4221-29	39747	4219-30	39745	4213-37	39739
11.00R20	4218-30	39844	4240-31	39757	4217-34	39781	4415-38	39752
12.00R20	4422-29	39859	4418-34	39784	4416-35	39753	4413-39	39751
13/80R20	4223-27	39849	4219-30	39745	4217-34	39781	4213-37	39739
14.00R20	**55.5x17	39444	**55.5x14	39442	**55.5x10	39441	**58x13	39446
14/80R20	4422-29	39859	4419-33	39756	4419-33	39756	4413-39	39751
10.00R22	4422-29	39859	4422-29	39759	4420-31	39757	4416-35	39753
11.00R22	4422-29	39859	4420-31	39757	4418-34	39784	4415-38	39752
12.00R22	4422-29	39859	4421-32	39758	4419-33	39756	4413-39	39751
8R22.5	3521-19	39826	3822-23	39732	3519-21	39725	3818-26	39730
9R22.5	3822-23	39832	3822-23	39732	3822-23	39732	3814-29	39728
10R22.5	4022-25	39838	4022-25	39738	4022-25	39738	4014-32	39734
11R22.5	4223-27	39849	4223-27	39749	4223-27	39749	4217-34	39781
11R22.5 D.L.	4223-27	39849	4223-27	39749	4223-27	39749	4215-35	39741
12R22.5	4422-29	39859	4422-29	39759	4420-31	39757	4416-35	39753
12.75R22.5	4422-29	39859	4422-29	39759	4420-31	39757	4416-35	39753
15R22.5	4423-30	39860	4421-32	39758	4419-33	39756	4413-39	39751
16.5R22.5	4522-34	39866	4520-36	39765	4520-36	39765	4513-44	39761
18R22.5	4522-34	39866	4518-38	39764	4515-41	39762	4513-44	39761
235/80R22.5	3822-23	39832	3822-23	39732	3822-23	39732	3816-28	39729
245/75R22.5	3521-19	39826	3521-19	39726	3519-21	39725	3818-26	39730
255/70R22.5	3822-23	39832	3822-23	39732	3822-23	39732	3816-28	39729
265/70R22.5	3822-23	39832	3822-23	39732	3820-24	39731	3814-29	39728
265/75R22.5	3822-23	39832	3822-23	39732	3820-24	39731	3814-29	39728
275/70R22.5	3822-23	39832	3822-23	39732	3820-24	39731	3814-29	39728
275/80R22.5	4022-25	39838	4222-26	39748	4020-26	39737	4214-32	39740
295/75R22.5	4224-23	39850	4222-26	39748	4220-28	39746	4214-32	39740
295/80R22.5	4223-27	39849	4223-27	39749	4221-29	39747	4215-35	39741
305/70R22.5	4224-23	39850	4222-26	39748	4220-28	39746	4217-34	39781
305/75R22.5	4224-23	39850	4220-28	39746	4220-28	39746	4217-34	39781
305/85R22.5	4422-29	39859	4422-29	39759	4420-31	39757	4416-35	39753
315/80R22.5	4422-29	39859	4422-29	39759	4420-31	39757	4416-35	39753
315/80R22.5 Opt	4422-29	39859	4422-29	39759	4420-31	39757	4415-38	39752
385/65R22.5	4423-30	39860	4421-32	39758	4421-32	39758	4415-38	39752
385/65R22.5 DL	4423-30	39860	4421-32	39758	4421-32	39758	4415-38	39752
425/65R22.5	4423-30	39860	4520-36	39765	4520-36	39765	4515-41	39762
445/50R22.5	4423-30	39860	4421-32	39758	4419-33	39756	4415-38	39752
445/65R22.5	4522-34	39866	4518-38	39764	4518-38	39764	*4814-44	39780
455/55R22.5	4423-30	39860	4520-36	39765	4520-36	39765	4515-41	39762
11.00R24	4423-30	39860	4421-32	39758	4421-32	39758	4415-38	39752
12.00R24	4522-34	39866	4522-34	39766	4520-36	39765	4515-41	39762
12.00R24 D.L.	**55.5X17	39444	**55.5X17	39444	**55.5X17	39444	**55.5X15	39443
13.00R24	**55.5X17	39444	**55.5X17	39444	**55.5X17	39444	**55.5X14	39442
14.00R24	**55.5X17	39444	**55.5X17	39444	**55.5X17	39444	**63X13	39456
11R24.5	4422-29	39859	4422-29	39759	4422-29	39759	4418-34	39784
11R24.5 D.L.	4422-29	39859	4422-29	39759	4422-29	39759	4416-35	39753
12R24.5	4422-29	39859	4422-29	39759	4422-29	39759	4416-35	39753
275/80R24.5	4224-23	39850	4222-26	39748	4220-28	39746	4217-34	39781
285/75R24.5	4224-23	39850	4222-26	39748	4220-28	39746	4217-34	39781
295/80R24.5	4422-29	39859	4422-29	39759	4422-29	39759	4418-34	39784
305/75R24.5	4422-29	39859	4422-29	39759	4422-29	39759	4418-34	39784
305/75R24.5 D.L.	4223-27	39849	4223-27	39749	4223-27	39749	4418-34	39784

*4814-44 Envelope Is A Robbins Accu-Fit Brand Envelope **Hand-Built Envelopes

All suggested envelope selections are to be used as a guide only. Variations in tire sizes, tire dimensions, precure tread designs, and precure tread thickness may require a smaller or larger envelope size. In some instances it may be necessary to measure the built tire to determine the correct envelope size. Capacities and specifications are subject to change without notice.

ROBBINS CMT Outside Envelopes



Envelopes with Valves

Used in chamber systems with rims or sealing rings.

Envelopes without Valve

Used in module type Vulcan and Cox chambers.

Order No. W/Valve	Size	O.D.	I.D.	Width	B to B	Order No. No Valve
39780	*4814	48	14	N/A	44	39880
39766	4522	45	22	15"	34	39866
39765	4520	45	20	15"	36	39865
39764	4518	45	18	15"	38	39864
39763	4516	45	16	15"	40	39863
39762	4515	45	15	15"	41	39862
39761	4513	45	13	15"	44	39861
39760	4423	44	23	12"	30	39860
39758	4421	44	21	12"	32	39858
39756	4419	44	19	12"	34	39856
39754	4417	44	17	12"	36	39854
39752	4415	44	15	12"	38	39852
39751	4413	44	13	12"	39	39851
39759	4422	44	22	10"	29	39859
39757	4420	44	20	10"	31	39857
39784	4418	44	18	10"	34	39855
39753	4416	44	16	10"	35	39853
39749	4223	42	23	10"	27	39849
39747	4221	42	21	10"	29	39847
39745	4219	42	19	10"	30	39845
39781*	4217	42	17	10"	34	
39741	4215	42	15	10"	35	39841
39739	4213	42	13	10"	37	39839
39750	4224	42	24	8"	23	39850
39748	4222	42	22	8"	26	39848
39746	4220	42	20	8"	28	39846
39744	4218	42	18	8"	30	39844
39740	4214	42	14	8"	32	39840
39782	4023	40	23	8"	23	39882
39738	4022	40	22	8"	25	39838
39737	4020	40	20	8"	26	39837
39736	4018	40	18	8"	27	39836
39735	4016	40	16	8"	29	39835
39734	4014	40	14	8"	32	39834
39733	4012	40	12	8"	34	39833
39732	3822	38	22	8"	23	39832
39731	3820	38	20	8"	24	39831
39730	3818	38	18	8"	26	39830
39729	3816	38	16	8"	28	39829
39728	3814	38	14	8"	29	39828
39727	3812	38	12	8"	32	39827
39726	3521	35	21	8"	19	39826
39725	3519	35	19	8"	21	39825
39724	3518	35	18	8"	22	39824
39723	3517	35	17	8"	23	39823
39722	3515	35	15	8"	25	39822
39721	3513	35	13	8"	27	39821
39720	3511	35	11	8"	29	39820
39719	3218	32	18	8.5"	19	39819
39718	3216	32	16	8.5"	22	39818
39717	3213	32	13	8.5"	24	39817
39716	3211	32	11	8.5"	27	39816
39715	3119	31	19	6"	16	39815
39714	3118	31	18	6"	17	39814
39713	3117	31	17	6"	18	39813
39712	3115	31	15	6"	21	39812
39711	3113	31	13	6"	22	39811
39710	3111	31	11	6"	24	39810
39709	2916	29	16	7.5"	19	39809
39708	2915	29	15	7.5"	20	39808
39707	2913	29	13	7.5"	22	39807
39706	2911	29	11	7.5"	24	39806
39705	2910	29	10	7.5"	25	39805
39704	2716	27	16	5"	15	39804
39703	2715	27	15	5"	16	39803
39702	2713	27	13	5"	18	39802
39701	2711	27	11	5"	20	39801
39700	2710	27	10	5"	21	39800

ROBBINS OTR Envelopes



- For use with rim & tube curing systems & sealing ring curing systems. Hand-Built for OTR tires, can be custom-made to customer requirements
- Envelope prices do not include the valve

Envelopes 58" O.D. and smaller include one valve installed. Envelopes 58.5" to 65" O.D. include one valve installed and one extra valve in the box. Envelopes 65.5" to 99.5" O.D. include two valves in the box for end user to install. Envelopes 100" O.D. and larger include four valves in the box for end user to install. Use Myers Order No. 41472 for valve pricing. Note: these are custom orders. Delivery is approximately 2 to 3 weeks.

Myers No.	Envelope Size	Suggested Tire Size
39450	60x15	38x20.00-16
39452	60x20	14.00R20 MILITARY
39460	63x19	16.00R20 MILITARY
39741	72x20	48x25.00-20
39475	79x15	48x31.00-20
39443	55.5x15	L1400-20ML
39443	55.5x15	14.00-21ML
39443	55.5x15	13.00-21ML
39444	55.5x17	12.00-24ML
39443	**55.5x15	12.00-24ML
39444	55.5x17	13.00-24ML
39444	55.5x17	14.00-24
39444	55.5x17	L12.00-24ML
39450	60x15	L14.00-24ML
39444	55.5x17	12.00-25ML2
39456	**63x13	14.00-25ML
39450	60x15	14.00-25ML
39442	**55.5x14	13.00-24
39444	55.5x17	13.00-24
39441	**55.5x10	15.5-25
39443	55.5x15	15.5-25
39456	**63x13	14.00-24
39444	55.5x17	14.00-24
39456	**63x13	17.5-25
39450	60x15	17.5-25
39469	**72x15	16.00-24
39740	72x18	16.00-24
39740	**72x18	16.00-25
39471	72x20	16.00-25
39475	**79x15	18.00-25
39475	79x15	18.00-25
39470	**72x18	20.5-25
39741	72 x 20	20.5-25
39482	91x20	21.00-25
39431	**81x18	23.5-25
39478	81x20	23.5-25
39432	**91x18	26.5-25
39482	91x20	26.5-25
39433	**97x18	29.5-25
39487	97x20	29.5-25
39487	97x20	26.5-29
39433	**97x18	29.5-29
39487	97x20	29.5-29
39483	**91x25	18.00-33
39483	91x25	18.00-33
39491	106x30	27.00-33
39497	114x30	33.5-33
39491	109x30	39/63-33
39498	119x30	37.5x33
39489	**100x28	21.00-35
39489	100x28	21.00-35
39491	**106x30	24.00-35
39491	106x30	24.00-35
39491	106x30	29.5-35
39497	114x30	33.25-35
39499	124x30	37.25-35
39499	124x30	37.5-39
None	110x33	33.25-29
39496	**109x30	21.00-49
39496	109x30	21.00-49
39496	**109x30	24.00-49
39496	109x30	24.00-49
39498	**119x30	27.00-49
39498	119x30	27.00-49

** Recommended for use with sealing rings

Note: All suggested envelope selections are used as a guide only. Variations in tire sizes, tire dimensions, precure tread designs, and tread thickness may require a smaller or larger envelope size. In some instances it may be necessary to measure the built tire to determine the correct envelope size. All capacities and specifications are subject to change without notice.

ROBBINS MRT Outside Envelopes



- For MRT retread systems only, use with Robbins Accu-Fit Inside envelopes

Order No	Envelope Size	Tire Size
39259	4422	305 /75R24.5 Deep
39249	4223	305 /75R24.5
39250	4224	285 /75R24.5
39250	4224	275 /80R24.5
39259	4422	12R24.5
39259	4422	11R24.5
39260	4423	1200R24
39259	4422	11.00R24
39259	4422	455 /55R22.5
39266	4522	445 /65R22.5 (18R22.5)
39245	4219	445 /50R22.5
39266	4522	425 /65R22.5 (16R22.5)
39259	4422	385 /65R22.5 (15R22.5)
39259	4422	315 /80R22.5
39250	4224	305 /85R22.5
39282	4023	305 /75R22.5
39282	4023	305 /70R22.5
39250	4224	295 /80R22.5
39282	4023	295 /75R22.5
39282	4023	275 /80R22.5
39232	3822	275 /70R22.5
39232	3822	265 /75R22.5
39232	3822	255 /80R22.5
39232	3822	255 /70R22.5
39232	3822	245 /75R22.5
39232	3822	235 /80R22.5
39266	4522	18R22.5
39266	4522	16R22.5
39259	4422	15R22.5
39250	4224	12.75R22.5
39250	4224	12R22.5
39250	4224	11R22.5
39282	4023	10R22.5
39232	3822	9R22.5
39259	4422	11.00R22
39259	4422	10.00R22
39260	4423	365 /80R20
39260	4423	14 /80R20
39266	4522	14.00R20
39250	4224	13 /80R20
39259	4422	12.00R20
39250	4224	11.00R20
39250	4224	10.00R20
39282	4023	9.00R20
39232	3822	8.25R20
39226	3521	305 /70R19.5
39226	3521	285 /70R19.5
39226	3521	265 /70R19.5
39219	3218	245 /70R19.5
39219	3218	225 /70R19.5
39219	3218	8R19.5
39213	3117	245 /70R17.5
39213	3117	215 /75R17.5
39232	3822	11R17.5
39226	3521	10R17.5
39219	3218	9.5R17.5
39219	3218	9R17.5
39219	3218	7.50-17
39219	3218	245 /75R16
39213	3117	235 /85R16
39209	2916	225 /75R16
39213	3117	215 /85R16
39219	3218	7.50R16LT
39226	3521	10.00R15
39219	3218	8.25R15
39213	3117	7.50R15

Note: All suggested envelope selections are to be used as a guide only. Variations in tire sizes, tire dimensions, precure tread designs, and precure tread thickness may require a smaller or larger envelope size. In some instances it may be necessary to measure the built tire to determine the correct envelope size. All Capacities and specifications are subject to change without notice.

ROBBINS CMT Outside Envelopes



- For retread systems using Inside envelopes. Recommend using Robbins Accu-Fit inside envelopes

Order No	Envelope Size	Tire Size
39759	4422-29	305 /75R24.5 Deep
39749	4223-27	305 /75R24.5
39750	4224-23	285 /75R24.5
39750	4224-23	275 /80R24.5
39759	4422-29	12R24.5
39759	4422-29	11R24.5
39760	4423-30	1200R24
39759	4422-29	11.00R24
39759	4422-29	455 /55R22.5
39766	4522-24	445 /65R22.5 (18R22.5)
39745	4219-30	445 /50R22.5
39766	4522-24	425 /65R22.5 (16R22.5)
39759	4422-29	385 /65R22.5 (15R22.5)
39759	4422-29	315 /80R22.5
39750	4224-23	305 /85R22.5
39782	4023-23	305 /75R22.5
39782	4023-23	305 /70R22.5
39750	4224-23	295 /80R22.5
39782	4023-23	295 /75R22.5
39782	4023-23	275 /80R22.5
39732	3822-23	275 /70R22.5
39732	3822-23	265 /75R22.5
39732	3822-23	255 /80R22.5
39732	3822-23	255 /70R22.5
39732	3822-23	245 /75R22.5
39732	3822-23	235 /80R22.5
39766	4522-24	18R22.5
39766	4522-24	16R22.5
39759	4422-29	15R22.5
39750	4224-23	12.75R22.5
39750	4224-23	12R22.5
39750	4224-23	11R22.5
39782	4023-23	10R22.5
39732	3822-23	9R22.5
39759	4422-29	11.00R22
39759	4422-29	10.00R22
39760	4423-30	365 /80R20
39760	4423-30	14 /80R20
39766	4522-24	14.00R20
39750	4224-23	13 /80R20
39759	4422-29	12.00R20
39750	4224-23	11.00R20
39750	4224-23	10.00R20
39782	4023-23	9.00R20
39732	3822-23	8.25R20
39726	3521-19	305 /70R19.5
39726	3521-19	285 /70R19.5
39726	3521-19	265 /70R19.5
39719	3218-19	245 /70R19.5
39719	3218-19	225 /70R19.5
39719	3218-19	8R19.5
39713	3117-19	245 /70R17.5
39713	3117-19	215 /75R17.5
39732	3822-23	11R17.5
39726	3521-19	10R17.5
39719	3218-19	9.5R17.5
39719	3218-19	9R17.5
39719	3218-19	7.50-17
39719	3218-19	245 /75R16
39713	3117-19	235 /85R16
39709	2916-19	225 /75R16
39713	3117-19	215 /85R16
39719	3218-19	7.50R16LT
39726	3521-19	10.00R15
39719	3218-19	8.25R15
39713	3117-19	7.50R15

Note: All suggested envelope selections are to be used as a guide only. Variations in tire sizes, tire dimensions, precure tread designs, and precure tread thickness may require a smaller or larger envelope size. In some instances it may be necessary to measure the built tire to determine the correct envelope size. All Capacities and specifications are subject to change without notice.

ROBBINS Accu-Fit II Inside Envelopes



- Overlapping Envelopes Sealed
- by Vacuum – No Mechanical Clamps, Bands or Other
- Devices Needed

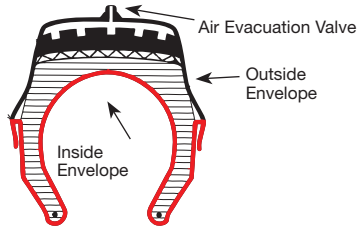

• Myers recommends using inside and outside envelope from same manufacturer.

Order No.	Envelope Size	Tire Size
41293	44x10-24.5	1200R24
41841	42x8-24.5	12R24.5, 11R24.5
41294	42x10-24.5	11R24.5
41582	40x8-24.5	305/75R24.5, 11R24.5
41203	38x8-24.5	285/75R24.5, 275/80R24.5
41295	44x12-22.5	445/55R22.5
41820	44x10-22.5	425/65R22.5, 16R22.5
41296	42x10-22.5	385/65R22.5, 1100R22, 455/55R22.5
41580	40x8-22.5	445/50R22.5, 315/80R22.5, 12.5R22.5, 10.00R22
41202	38x8-22.5	295/80R22.5, 295/75R22.5, 275/80R22.5, 11R22.5
41297	35x8-22.5	275/70R22.5, 265/70R22.5, 255/80R22.5,
41298	42x10-20	365/80R20
41299	40x8-20	335/80R20
41205	38x8-20	1000R20, 900R20
41300	35x8-20	825R20
41301	32x8-20	750-20
41085	42x10-19.5	445/65R19.5
41084	40x8-19.5	15R19.5
41080	35x8-19.5	305/70R19.5
41081	32x8-19.5	285/70R19.5, 265/70R19.5, 8R19.5
41083	29x7-19.5	245/70R19.5, 225/70R19.5, 8R19.5
41092	35x8-17.5	11R17.5, 10R17.5
41088	32x8-17.5	9R17.5, 10R17.5, 9.5R17.5
41087	29x7-17.5	245/70R17.5, 215/75R17.5, 7.50-17
41086	27x5-17.5	205-75R17.5
41093	32x8-16	12R16.5, 235/65R16
41090	29x7-16	245/75R16, 750R16, 235/85R16, 215/85R16
41089	27x5-16	225/75R16
39900	10x15 HB	10.00R15
39901	8.5x15 HB	8.25R15
39902	7.5x15 HB	7.50R15

Speed Tire Spreader

A powerful hand spreader ideal for inspection work or used in pairs for holding beads apart when making section repairs. Includes locking pin to prevent spreader from unlocking during use and instruction sheet.



Order No.	Mfr. No.	Description	Ship Wt.
50926	M-1	Speed Tire Spreader	4 lbs. - 2 kg

ROBBINS Envelopes with Valve



- For industrial size tires
- For use with rim & curing tube curing system
- Customized sizes to fit industrial tire sizes available

Order No.	Envelope Size	Tire Size	Order No.	Envelope Size	Tire Size
39728	3814-29	10/11.00-15	41512*	252-15	7.50-10
39717	3213-24	8.25-15	41744*	252-15	7.50-10 No Valve
39709	2916-19	7.00-15	41794*	240-16	6.50-10 No Valve
39701	2711-20	7.00-12	41795*	240-16	6.50-10
41496**	270-22	7.00-12			

* Accu-Fit Type, ** For use with sealing rings

ROBBINS Precure Uni-Tubes



- For precure & mold cure retreat systems
- .302 Valve cap thread



Order No.	Tube Size	Qty. Per Box	Ship Wt.
41540	UN-12" Medium	2	9 lbs. - 4 kg
41541	UN-13" Small	2	11 lbs. - 5 kg
41542	UN-13" Medium	2	9 lbs. - 4 kg
41544	UN-14" Small	2	11 lbs. - 5 kg
41545	UN-14" Medium	2	11 lbs. - 5 kg
41546	UN-14" Large	2	12 lbs. - 5 kg
41547	UN-14" Extra Large	2	14 lbs. - 6 kg
41548	UN-15" Small	2	12 lbs. - 5 kg
41551	UN-15" Medium	2	11 lbs. - 5 kg
41555	UN-15" Large	2	11 lbs. - 5 kg
41869	UN-700R15	2	10 lbs. - 5 kg
41870	UN-750R15/ 8.25-15	2	10 lbs. - 5 kg
41556	UN-1000R15, 1100R15	2	14 lbs. - 6 kg
41871	UN-700R16	2	12 lbs. - 5 kg
41872	UN-750R16	2	12 lbs. - 5 kg
41882	UN-10-16.5	2	12 lbs. - 5 kg
41679	7.00/7.50-17/18	2	
41972	UN-8R19.5, 9R-19.5, 245/70R19.5, 225/70R19.5, 245/70R19.5	2	11 lbs. - 5 kg
41595	UN-700R20, 750R20	2	12 lbs. - 5 kg
41873	UN-825R20	2	15 lbs. - 7 kg
41874	UN-900R20	2	15 lbs. - 7 kg
41875	UN-1000R20	2	16 lbs. - 7 kg
41878	UN-1100R20, 1200R20	2	20 lbs. - 9 kg
41876	UN-1000R22, 11R22.5, 12R22.5	2	19 lbs. - 9 kg
41564	UN-15R22.5, 16.5R22.5, 315/80R22.5	2	30 lbs. - 14 kg
41877	UN-1100R22	2	23 lbs. - 10 kg
41557	UN-245/75R22.5, 255/70R22.5	2	14 lbs. - 6 kg
41558	UN-265/75R 22.5, 275/80R22.5, 9R22.5, 10R22.5	2	17 lbs. - 8 kg
41559	UN-295/75R22.5	2	17 lbs. - 8 kg
41563	UN-285/75R24.5	2	19 lbs. - 9 kg
41879	UN-1100R24	2	27 lbs. - 12 kg
41880	UN-1200R24, 11R24.5, 12R24.5	2	23 lbs. - 10 kg
41881	UN-1300R24, 1400R24	2	31 lbs. - 14 kg
41627	13.00/14.00-20	1	54 lbs. - 25 kg
41881	13.00-24	1	52 lbs. - 24 kg

2 per Carton

Envelope Measurement Methods

Base envelope selection on the outside diameter & bead-to-bead measurement of the built retreat unit.

- 1.) Identify the envelope sealing method
- 2.) Measure built retreat tire diameter to estimated envelope O.D.
- 3.) Measure the built retreat unit from sealing point to sealing point and add 2" to estimate envelope bead to bead.
- 4.) Compare the measurement to the bead-to-bead dimensions on the chart below for proper fit. Note: If the measurement falls between two bead-to-bead envelope sizes, use the larger size.

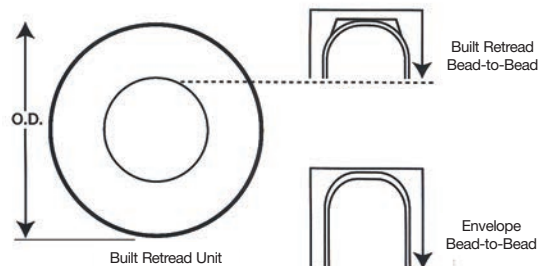

ROBBINS Envelope Lube

Spray on the inside of the envelope. Spraying while the envelope is hot helps it dry faster. Spray on as needed. The quart container is a convenient spray bottle. Ready to use, no dilution required. Available in 55-gallon drums.



Order No.	Mfr. No.	Size	Ship Wt.
41398	5611	1 Quart	3 lbs. - 2 kg
41399	5612	1 Gallon	9 lbs. - 4 kg
41397	5613	5 Gallons	44 lbs. - 20 kg

ATEC Envelope Release Lubricant

A water-based silicone release lubricant. New envelopes require 4 or 5 initial applications and again in approximately 6 cures. Re-apply when there are signs of sticking. Non-toxic and non-flammable.



Order No.	Mfr. No.	Description	Ship Wt.
45209	ERL-170	Envelope Release Lubricant	44 lbs. - 20 kg

SURE-SHOT Sprayer

Metal, one quart pressure sprayer for spraying mold lubricants. Holds up to 200 lbs. pressure. Shoots a wide-area mist spray or jet stream up to 20'. Fast, easy refilling with standard air chuck, hand pump, or CO2 cartridge.



Order No.	Mfr. No.	Description	Ship Wt.
56435	HPN-52D	1 Qt. Chrome Plated Brass Tank	3 lbs. - 1 kg
56436	HPN-1952	1 Qt. Enameled Steel Tank	3 lbs. - 1 kg
56438	HPN-325	6" Extension Nozzle	1 lbs. - 1 kg
56439	K-10	Repair Kit for Sprayers: Complete (13 Parts)	2 lbs. - 1 kg
56440	A-5	Repair Kit for Sprayers: (8 Parts)	1 lbs. - 1 kg

B&J Precure Envelope Tester

- Tests for leaks in less than 20 seconds



Designed to exhaust trapped air between the envelope and precure tread on envelopes with valves, especially useful with envelope sealing rings. Recommended for Vulcan TB-52 (B manifold), Cedco, Salisbury and other chambers. A check valve is available to keep the vacuum drawn on already checked envelopes for a longer test, while other envelopes are being checked.

Order No.	Mfr. No.	Description	Ship Wt.
46001	33-400	Envelope Tester	25 lbs. - 11 kg
46002	33-405	Check Valve	1 lbs. - 1 kg

OLSON Envelope Expander

- Increase envelope life & reduce replacement cost
- Reduce the risk of hand or finger injuries
- Handles tire sizes - 7.50 x 16 thru 18 x 22.5 or 45" maximum tire diameter



50706
Shown with Optional
50738 Tire Lift

Fits and removes curing envelopes at the touch of a button. Slip the envelope onto the expansion fingers, and air operated cylinders stretch it onto the tire automatically. The 600 model is floor mounted and swings out of the way when not in use. Recommended for Branick band type spreaders or T-racks. The 750 model expander is for use with monorail systems. It mounts under the monorail and lets tires pass through center to continue down the line. The E-Z Lift is for use under the 50706 Enveloper, lifts the tire on and off the "J" hook and positions it for installing sealing rings. Requires 120 psi.

Upper Finger Stop Kit (50741) keeps the fingers in a true circle and spreads the envelope uniformly reducing the danger of tearing. For use on the #750 Monorail Enveloper.

Order No.	Mfr. No.	Description	Ship Wt.
50705	#600	Stationary Enveloper "E"	340 lbs. - 155 kg
50710	9610	Tire Lift for #600 Enveloper	
50706	#750	Monorail Enveloper "M"	300 lbs. - 135 kg
50738	#700	Tire Lift for 750 Enveloper	300 lbs. - 135 kg
50708		Repl. Rubber Hose Including Ends for Expanding Arms	1 lbs. - 1 kg
50709		Rubber Hose Only No Ends	1 lbs. - 1 kg
50675		50' Bulk Rubber Hose	3 lbs. - 1 kg
50741	#9032	Upper Finger Stop Kit	
50713		Replacement Air Cylinder	28 lbs. - 13 kg

Envelope Storage Carts

- Holds up to 800 lbs.
- Keeps envelopes off the floor & away from damage
- Five colors - sort envelopes by size



Manufactured of durable, high impact polyethylene with four ball bearing casters making it easy to move. Wide, rolled over edge will not snag envelopes when placing or removing. Cart size: 46" long x 34" wide x 32-1/2" high.

Order No.	Description	Ship Wt.
84610	Envelope Storage Cart - Blue	68 lbs. - 31 kg
84611	Envelope Storage Cart - Yellow	68 lbs. - 31 kg
84612	Envelope Storage Cart - Red	68 lbs. - 31 kg
84613	Envelope Storage Cart - Grey	68 lbs. - 31 kg
84614	Envelope Storage Cart - Green	68 lbs. - 31 kg

Tire Talc

Keeps casings, tubes, rims and patches from adhering to each other. Ideal for dusting curing tubes, air bags, etc.

Order No.	Mfr. No.	Description	Ship Wt.
46608	RM-23	1 Lb. Can	1 lbs. - 1 kg
46610	RM-23X	50 Lb. Bag	55 lbs. - 25 kg



Envelope Seal Couplers & Adapters



Effective when using a vacuum to test the seal of the envelope prior to loading the tires in the chamber. The adapter and coupler must be used together; it is not interchangeable with other systems.

Order No.	Mfr. No.	Description
41472	3245	Envelope Valve
41498	5079	Envelope Washer (Rubber)
41471	BH1-60Y-4FP	Coupler 1/4" FPT Sureseal
41486	VB75-013	Viton O-Ring for 41471 Sold Each (2) Req. Per Coupler - 10 per pack
41449	BH61-711	Adapter .482 Sureseal
54511	TW-12	Teflon O-Ring for 41449 (10 Pkg.)

Wide Base Envelope Valves



The wide 2 1/4" base helps the valve "bridge" the gap between wide tread voids on many aggressive designs. One-piece design eliminates the potential leak point of multi-piece valves.

Order No.	Mfr. No.	Description
41454	VDT-000	Wide Base .482 Threaded Valve

CIMS Date Code Tags



Retread identification tags for use on matrix, precure, and flexcure retread systems. Precure Combo Tags combine shop code and weekly date code onto one tag. "C" and "M" Series Date Code Sets. Full year sets contain 10 weekly Date Tags for 52 weeks. Precure Shop Code Tags can be used with all precure and flexcure systems, stamped with your shop code and/or optional code.

Order No.	Mfr. No.	Description	Size	Slot Center
45782	4260	Precure Combo Tags, Combines Shop & Weekly Date Codes	2 1/2" x 1/2"	-
45781	4215	Precure Shop Code Tags, Prestamped, Reusable	2" x 1/2"	-
45780	4206	"M" Style Date Code Set, Jan. thru Dec. - 1 Year.	1 3/8" x 3/8"	1 1/16"
45777	4208	"M" Style 1/2 Year Order after May 1st	1 3/8" x 3/8"	1 1/16"
45778	4200	"C" Style Date Code Set, June thru May - 1 Year	1 3/8" x 3/8"	1 5/16"
45779	4202	"C" Style Date Code Set, 1/2 Year Order After Dec. 1st	1 3/8" x 3/8"	1 5/16"

ROOVERS Aluminum Embossing Tape



Supplied in convenient pre-measured easy to load rolls. They are specially controlled for width, thickness and temper of material. Other sizes available, call for details.

Order No.	Mfr. No.	Tape Size Width	Gauge	Rolls Per Carton	Length Per Roll
45766	2643	1/2"	.015	10	120

Baird-Style Couplers & Adapters



Designed for use in the retread operation. Features patented teflon sealing system that uses 5 flat teflon washers. Couplers are for high temperature applications up to 550°F. and uses a locking pin system in place of balls for a tighter locking system to the adapter.

Order No.	Mfr. No.	Description
54372	874-6	Straight-Thru w/ 90° Side Exhaust Coupler
54376	874	90° Hose Inlet Coupler (Supply)
54378	1	Teflon Repl. Washers 5 Per Coupler Required
54370	814	.482 Envelope Adapter for 874-6 Coupler
54371	814S	Replacement Seal for 54370 (Bag of 100)
54463	812	.302 Valve Stem Adapter for 894 & 874 Couplers
54373	812S	Gasket For 54463 (Bag of 100)

1/4" Air Coupler & Adapters

- Inflate supply side of chamber (curing tube side)



Order No.	Mfr. No.	Description
54473	1000	Coupler 1/4" fpt
54483	W-1000 "Old"	Repl. Washer Buna "M" to 200° 10 Per Pack Smaller I.D.
54484	3000-143 "Old"	Viton Hi-Temp Washer 10 Per Pack Smaller I.D.
54222	NEW Buna "M"	Repl. Washer Buna "M" to 200° 10 Per Pack Larger I.D.
54496	NEW "O" Viton Ring	Viton Hi-Temp Washer 10 Per Pack Larger I.D.

Adapters

Order No.	Mfr. No.	Adapter Thread	Order No.	Mfr. No.	Adapter Thread
54474	12	1/8" MPT	54373	ES	.302 Adapt. Repl. Seal (100)
54475	10	1/4" MPT	54480	F	.482F Valve Cap THD.
54476	14	3/8" MPT	54371	FS	.482 Adapt. Repl. Seal (100)
54477	11	1/4" FPT	54481	16	1/4" Hose Barb End
54478	15	3/8" FPT	54482	17	3/8" Hose Barb End
54479	E	.302F Valve Cap			

1/4" Envelope Coupler & Adapters

- Exhaust side of chamber (envelope side)
- Compatible for use in Bandag chambers



Order No.	Mfr. No.	Description
54504	CST17BA	Exhaust Flow Thru Coupler
		Aflas Wide Hi-Temp O-Ring 10 Per Pack
		Aflas Thin Hi-Temp O-Ring 10 Per Pack
Adapters		
54510	1137	Envelope Adapter .482 Thread
54511	TW-12	Teflon O-Ring 10 Per Pack



Contact your local Myers Branch for complete information & specifications

Replacement Chamber Seals



EDPM O-Rings are generally black in color and withstand temperatures in the 250° to 320°F range. Silicone O-Rings are generally red or pink in color and withstand temperatures to 500°.

Order No.	Application	Type	Diameter
Miscellaneous Horizontal Chambers			
34927	Michelin/Cure Tech	EPDM Seal	
34775	Salisbury 12, 15, 23, 25 Tire	EPDM O-Ring	½"
34776	Salisbury 12, 15, 23, 25 Tire	Silicone O-Ring	½"
34726	Alloy Craft 57"	EPDM Seal	
34777	Bandag 1973 & Newer, 11, 22, Tire	EPDM Seal	
34778	Bandag Pre-1973, 10, 20 Tire	EPDM Seal	
34792	Hercules/Cedco 12, 15, 22, 25 Tire	EPDM Seal	

See illustrations above

Vulcan Chambers

34731	TB-436	EPDM O-Ring	¾"
34760	TB-436	Silicone O-Ring	¾"
34725	TB-40, 45, 48	EPDM O-Ring	¾"
34761	TB-40, 45, 48	Silicone O-Ring	¾"
34729	TB-54, 52, 526, 606 & 706	EPDM O-Ring	¾"
34762	TB-54, 52, 526, 606 & 706	Silicone O-Ring	¾"
34728	TB-62	EPDM O-Ring	¾"
34763	TB-62	Silicone O-Ring	¾"

Longmile Vertical Chambers

34775	All	EPDM O-Ring	½"
34776	All	Silicone O-Ring	½"

Oliver/Cox Chambers

34780	P-41 Chamber	EPDM O-Ring	¾"
34781	T-50 Chamber	EPDM O-Ring	¾"
34782	T-55 Chamber	EPDM O-Ring	¾"

Heintz Chambers

34787	MC-40, #A Heintz	Silicone O-Ring	¾"
34788	MC-46, #B Heintz	Silicone O-Ring	¾"
34789	MC-50, #C Heintz	Silicone O-Ring	¾"

¼" and ¾" Silicone material sold by the foot for Temp-R-Tred, Lodi, Oliver, and Longmile Chambers

34790	¼" Silicone Material Per Ft.		
34791	¾" Silicone Material Per Ft.		

O-Ring Lubricants

34727	5.3 Oz. Silicone O-Ring Lubricant Tube DOW #111		
34717	8 Lb. Silicone O-Ring Lubricant Bucket DOW #111		
45215	Silicone Spray		

TIP: Be sure to check all hoses, couplers and connections for air leaks! See page 73 for order information on hose tester.

Multi-Tire Curing Chambers

- 6 To 25 tire capacity & tire sizes up to 14.00-24

Chambers are available in either steam or electrically heated models. Features include: automatic controls to provide uniform temperature and pressure throughout the curing cycle; hydraulically operated quick-lock chamber door; top mounted inside track and tire hanger brackets. Chambers are fully insulated for optimum efficiency and economical operation.

Curing Chamber Charts

- For Oliver, Goodyear, Salisbury, Hercules/Cedco, Cure Tech (Michelin) & other type chambers

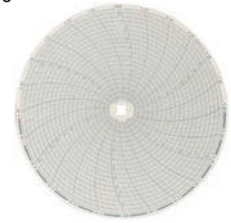

Compatible for BANDAG

Order No.	Diameter	Application	Description	Qty. Per Box
PARTLOW Temperature Charts - 24 Hours				
34107	10" Dia.	50 - 250	A225F, #002-053-03	100
34108	10" Dia.	150 - 350	002-213-883	100
34113	10" Dia.	100 - 350	A335F, 002-060-03	100

Pen for Partlow Temperature Recorder

34116	Red Short Stem	605-004-03	Sold/Each
-------	----------------	------------	-----------

DICKSON Pressure Charts - 24 Hours

34100	8" Dia.	0 - 200	C456	60
34101	4" Dia.	40/0/50	C011	60
34102	4" Dia.	0-100	C010, DPC Chart	60
34112	4" Dia.	0 - 500	C028	60

Pens for Dickson Pressure And DPC Recorder

34104	Red	P-222, 700-022200	Pkg. 6
34105	Blue	P-226, 700-022600	Pkg. 6

Salisbury Type

DICKSON Temperature Charts - 24 Hours

34103	8" Dia.	0 - 500	C428	60
-------	---------	---------	------	----

Pen for Dickson Temperature Recorder

34105	Blue	P-226, 700-022600	Sold Pkg./6
-------	------	-------------------	-------------

DICKSON Pressure Charts - 24 Hours

34100	8" Dia.	0 - 200	C456	60
-------	---------	---------	------	----

Pens for Dickson Pressure Controller

34104	Red	P-222, 700-022200	Sold Pkg./6
34105	Blue	P-226, 700-022600	Sold Pkg./6

HERCULES/CEDCO Type

PARTLOW Temperature Charts - 24 Hours

34106	10" Dia.	0 - 400	#002-138-02	100
-------	----------	---------	-------------	-----

Pen for Partlow Temperature Recorder

34109	Red Long Stem	#605-004-02	Sold/Pkg. 5
-------	---------------	-------------	-------------

DICKSON Pressure Charts - 24 Hours

34100	8" Dia.	0 - 200	C456	60
-------	---------	---------	------	----

Pens for Dickson Pressure Controller

34104	Red	P-222, 700-022200	Sold/Pkg. 6
34105	Blue	P-226, 700-022600	Sold/Pkg. 6

Salisbury / Cedco (Wingfoot) Recorder

Honeywell Recorder Chart

34117	12" Dia.	80663-90/30755	317-KC	100
-------	----------	----------------	--------	-----

All items priced per box.

Chamber Hoses

Precure Chamber Inflation & Exhaust Hoses

- ¼" I.D hose with ¼" mpt fittings

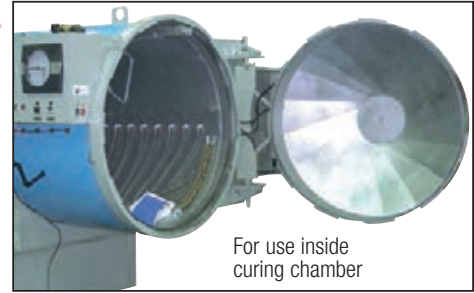

↑
Inside Spring

↑
Outside Guard



¼" Inflation Hoses (Curing Tube Side)

Teflon hose with steel braided cover, are used inside the chamber for inflating the curing tube and on the envelope for evacuating the air between the tread and the envelope.



Without Inside Spring & No Outside Guard

Order No.	Length	Order No.	Length	Order No.	Length
48126	30"	48135	84"	48144	138"
48127	36"	48136	90"	48145	144"
48128	42"	48137	96"	48146	150"
48129	48"	48138	102"	48147	156"
48130	54"	48139	108"	48148	162"
48131	60"	48140	114"	48149	168"
48132	66"	48141	120"	48150	174"
48133	72"	48142	126"	48151	180"
48134	78"	48143	132"		

With Outside Guard Only No Inside Spring

Order No.	Length	Order No.	Length	Order No.	Length
48100	30"	48109	84"	48118	138"
48101	36"	48110	90"	48119	144"
48102	42"	48111	96"	48120	150"
48103	48"	48112	102"	48121	156"
48104	54"	48113	108"	48122	162"
48105	60"	48114	114"	48123	168"
48106	66"	48115	120"	48124	174"
48107	72"	48116	126"	48125	180"
48108	78"	48117	132"		

Bulk	
44211	¼" Bulk Stainless Hose (Sold Per Foot) 100' Max. Length
49008	¼" Inner Spring Only (Sold Per Foot) 25' Max. Length
49010	Outside Guard Only (Sold Per Foot) 25' Max. Length

¼" Exhaust Hoses (Envelope Side)

The exhaust hose also includes an inner spring to keep the hose from collapsing.

With Inside Spring Only No Outside Guard

Order No.	Length	Order No.	Length	Order No.	Length
48152	30"	48161	84"	48170	138"
48153	36"	48162	90"	48171	144"
48154	42"	48163	96"	48172	150"
48155	48"	48164	102"	48173	156"
48156	54"	48165	108"	48174	162"
48157	60"	48166	114"	48175	168"
48158	66"	48167	120"	48176	174"
48159	72"	48168	126"	48177	180"
48160	78"	48169	132"		

With Inside Spring & Outside Guard

Order No.	Length	Order No.	Length	Order No.	Length
48178	30"	48187	84"	48196	138"
48179	36"	48188	90"	48197	144"
48180	42"	48189	96"	48198	150"
48181	48"	48190	102"	48199	156"
48182	54"	48191	108"	48200	162"
48183	60"	48192	114"	48201	168"
48184	66"	48193	120"	48202	174"
48185	72"	48194	126"	48203	180"
48186	78"	48195	132"		

1/4" Exhaust & inflation hoses may be custom ordered up to 300" long with spring guard to fit your requirements. Longer lengths available without spring guard. Call 800-998-9897

Teflon Steam Hose



¾" MPT teflon hose with steel-braided cover and spring guard. Spring guard covers entire hose length.

Order No.	Length	Order No.	Length	Order No.	Length
44180	18"	44185	30"	44189	48"
44181	20"	44184	32"	44190	54"
44183	24"	44187	36"	44191	60"
44182	27"	44186	42"		

Bulk	
49009	¾" I.D. Hose with Spring Guard (Sold Per Foot)
44217	¾" I.D. Teflon Steel Braided Hose (Sold Per Foot)
54311	¾" FIP to ¼" MPT Reducer Bushing

Custom Steam Hose Available on Request

Any length of ¾" MPT teflon hose with steel-braided cover and spring guard is available from your local Myers Sales Office..



**Call Today
800-998-9897**

MYERS Chamber Hose Tester

- Tests couplers & hoses preventing expensive leaks
- Attach "in-shop" adapter on one end & "envelope adapter" on the other



Step 1: Install the in-shop air line to the ball valve on the tester

Step 2: Install the chamber exhaust hose to the end of the tester where the envelope adapter has been attached. Be sure to close the 2-way or 3-way exhaust hose ball valve on the chamber exhaust hose line to be tested.

Step 3: Open the ball valve and pressurize the exhaust hose and check for and correct any leaks found in the hose or coupler. Close the ball valve and look for a drop in pressure on the gauge. If there is a drop in pressure, there's a leak. To locate a leak use the Myers 56435 Sure Shot Sprayer filled with Myers 46618 Leak Detector.

Order No.	Description
46817	Myers Chamber Hose Tester
56435	Sure Shot Sprayer
46618	Leak Detector 1-Gallon

Thermometer

- Dual range

4 1/2" dial can be read easily from a distance. Has 5 ft. flexible armored connecting tube, 1/2" union connected bulb. Temperature range of 100° to 350°F. (38° to 177°C.)



Order No.	Mfr. No.	Description
46815	V80341	Thermometer

Liquid-Filled Gauge

- Other liquid-filled & vacuum gauges available, contact us

For use as replacement on curing chambers and other equipment. Face diameter 2 1/2"; 0-160 psi in 2 lb. increments; 1/4" mpt center back mount, accurate +/- 1.5%



Order No.	Mfr. No.	Description
49026	213.53	Liquid Filled Gauge

1/4" MPT Clock Gauges

- Other dry, liquid-filled & vacuum gauges available, contact us.

Use on air, steam or any other pressure medium which does not attack brass. Install siphon under gauge when used on steam.

Order No.	Mfr. No.	Dial Size	Lbs. Pressure
44645	*AS-7D	2"	0-300
44641	AS-7G	2 1/2"	0-60
44642	AS-7A	2 1/2"	0-160
44643	AS-7B	2 1/2"	0-200
44644	AS-7C	2 1/2"	0-300
44646	AS-7BB	3 1/2"	0-300
44647	AS-7E	4 1/2"	0-200

*With 1/4" MPT back connection.



44645



44642

MYERS Steam Coupler & Adapter for Press Type Matrices

- Interchangeable with Hansen

For Heintz, Ace, Bacon-American and Lodi steam matrix hook-up. Special quick connect/disconnect couplers. For steam and return lines. Double O-Rings in coupler provide positive seal and extra safety during coupling and uncoupling.



Order No.	Mfr. No.	Description
44533	A4S	3/8" Myers Coupler
44534	A4P	3/8" Myers Adapter
44535		1/2" Myers Coupler
Repair Kit for Myers Special Coupler & Adapters		
44537	H68E-67K	Consists Of 1 Each Valve Spring, Snap Ring, O-Ring, Valve Assembly
44569	H10C-R	Repl. O-Ring for 44533 Coupler

HANSON Steam Coupler & Adapter for Press Type Matrix

Brass couplings for Heintz, Bacon-American, Lodi and others. Special seals to withstand special temperatures.



Order No.	Mfr. No.	Description
44566	H10C-S	3/8" Coupler (Bacon-American 41109, Heintz B3-HD-21Y, Lodi B3-H21)
44567	H10C-P	3/8" Plug (Bacon-American 41110, Heintz B3-HD-2Y)
44568	H10C-V	Repl. Valve Assy. BVA-3HKA-192
44569	H10C-R	Repl. Viton O-Ring, Black 10 Pkg

PARKER Steam Coupler & Adapters

Push in to connect, pull back to disconnect. Swivel action brass couplers and brass adapter. Leak-proof when attached.



Order No.	Mfr. No.	Description
44572	BH2-60W	1/4" Coupler
44573	BH2-61W	1/4" FPT Adapter
44574	1-54-310	1/4" MPT Adapter
Repair Kit		
44577	2-015 (ES40-8)	Repl. O-Ring for 44572 (2 Req.)

Filter-Regulator-Lubricators

- See page 67 for complete listing of filters, regulators & lubricators



All combination units with manual drain filter, lubricator, and regulator are supplied with 0-300 lb. pressure gauge and 0 to 250 psi reduced pressure range. Furnished assembled. Available for 1/4", 3/8", 1/2", 3/4" and 1" lines.

Order No.	Mfr. No.	Size	Ship Wt.
54655	C628-02-FRL	1/4" Filter-Regulator-Lubricator	6 lbs. - 3 kg
54770	C628-03-FRL	3/8" Filter-Regulator-Lubricator	6 lbs. - 3 kg
54657	C628-04-FRL	1/2" Filter-Regulator-Lubricator	10 lbs. - 5 kg
54739	C628-06-FRL	3/4" Filter-Regulator-Lubricator	19 lbs. - 9 kg
54741	C628-08-FRL	1" Filter-Regulator-Lubricator	19 lbs. - 9 kg

Curing Bladders

ROBBINS PIV Push-In Valve Type Curing Tubes

- For mold cure retreading systems
- For tube-type Marangoni, Italmatic, Cisap & Cima curing presses
- Recommend using flap with the PIV type tube



Order No.	Tube Size	Ship Wt.
41850	12" Small	6 lbs. - 3 kg
41851	13" Small	7 lbs. - 3 kg
41852	13" Medium	9 lbs. - 4 kg
41845	13" Large	12 lbs. - 4 kg
41853	14" Small	9 lbs. - 4 kg
41854	14" Medium	11 lbs. - 5 kg
41855	14" Large	13 lbs. - 6 kg
41856	15" Small	9 lbs. - 4 kg
41857	15" Medium	13 lbs. - 6 kg
41858	15" Large	13 lbs. - 6 kg
41859	15" Extra Large	16 lbs. - 7 kg
41847	15" Super Large	17 lbs. - 8 kg

Order No.	Tube Size	Ship Wt.
41860	16" Medium	15 lbs. - 7 kg
41848	16" Large	18 lbs. - 8 kg
41861	700 /750-20	18 lbs. - 8 kg
41862	825-20	20 lbs. - 9 kg
41863	900-20	21 lbs. - 10 kg
41864	1000-20	26 lbs. - 12 kg
41865	1100-20	27 lbs. - 12 kg
41866	12 /1300-20	33 lbs. - 15 kg
41867	11 /12-22.5, 1000-22	27 lbs. - 12 kg
41868	11 /12-24.5, 1100-24	36 lbs. - 16 kg

ROBBINS PIV II Push-In Valve Type Curing Tubes

- For mold cure retreading systems
- Must use a flap
- For tube-type Marangoni, Italmatic, Cisap & Cima curing presses



Order No.	Tube Size	Ship Wt.
41280	14" Large	7 lbs. - 4 kg
41281	15" Large	7 lbs. - 4 kg
41282	16" Medium	8 lbs. - 4 kg
41283	16" Large	9 lbs. - 5 kg
41284	700 /750-20	10 lbs. - 5 kg
41285	825-20	10 lbs. - 5 kg
41286	900-20	11 lbs. - 6 kg
41287	1000-20	13 lbs. - 6 kg

Order No.	Tube Size	Ship Wt.
41288	1100-20	14 lbs. - 7 kg
41289	12/1300-20	16 lbs. - 8 kg
41290	11 /12-22.5, 1000-22	17 lbs. - 8 kg
41291	16.5-22.5, 8565R22.5	17 lbs. - 8 kg
41292	11 /12-24.5, 1100-24	18 lbs. - 9 kg

ROBBINS Euro-Tubes

- For mold cure retread systems
- Features cured-in valve – alternative to push-in valve type curing tubes
- For tube type Marangoni, Italmatic, Cisap & Cima curing presses



Order No.	Mfr. No.	Tire Size	Ship Wt.
41673	5368	900-20	25 lbs. - 12 kg
41801	5370	1000-20	27 lbs. - 13 kg
41674	5374	1000-22;1100-22.5	27 lbs. - 13 kg
41676	5378	15 /16.5-22.5	50 lbs. - 23 kg
41675	5380	11/12R-24.5	31 lbs. - 14 kg

Rhein Chemie (Formerly Tire Curing Bladders)

- For bladder-type Marangoni, Italmatic, Cisap, Cima & SIO curing presses
- Contact us for the complete tire curing bladder product line



Order No.	Mfr. No.	Description	Ship Wt.
41120	6228	13"-15" x Small	11 lbs. - 5 kg
41122	7632	13"-15" x Large	11 lbs. - 5 kg
41130	6297	14" Medium	11 lbs. - 5 kg
41131	8911	14" Large	11 lbs. - 5 kg
41126	8376	20/22/22.5	29 lbs. - 13 kg
41128	2895	20" Large	33 lbs. - 15 kg
41124	8177	22/22.5/24.5	34 lbs. - 15 kg

CONTINENTAL Bladders

- For bladder-type Marangoni, Italmatic, Cisap, Cima & SIO Curing presses
- Contact us for the complete Continental bladder product line



Order No.	Mfr. No.	Description	Ship Wt.
41100	RP 13 /3	560-13 To 700-14	8 lbs. - 4 kg
41102	RP 13 /5	650-13 To E 78-15 (185-15)	9 lbs. - 4 kg
41103	RP 13 /7	E 78-14 (185-14) To H 78-15 (205-15)	10 lbs. - 5 kg
41104	RP 13 /9	Large Passenger And Small Commercial Truck	12 lbs. - 6 kg
41107	RP20 /5	900-20 & Up	23 lbs. - 10 kg
41109	H 10	Aircraft Special Application	18 lbs. - 8 kg
41114	BN2	Aircraft Special Application	13 lbs. - 6 kg
41115	H 15 /5	Aircraft Special Application	19 lbs. - 9 kg
41116	B20 /7	Aircraft Special Application	32 lbs. - 14 kg
41119	B20 /5	Aircraft Special Application	32 lbs. - 14 kg

Push-In Valve

- For use with PIV curing tubes
- ¼" BSPT (British Pipe Thread)



Order No.	Description
21220	Push In Valve

Graphite Lubricating Stick



High heat lubricant used for lubricating matrix retainer ring. Easier insertion and removal. Prevents rust and corrosion. Individually tubed.

Order No.	Mfr. No.	Description
46663	TD-20	Graphite Lubricating Stick

Matrix Vent Drill Bits



For cleaning matrix vent holes

Order No.	Mfr. No.	Description
02439	THD-332	¾" x 4" Matrix Vent Drill Bits
02440	THD-564	¾" x 5" Matrix Vent Drill Bits



ROBBINS Double Dot Curing Tubes

- Collapsible rim type curing tubes for mold cure retreading systems
- .482 Valve Spud Thread

Note: Nomenclature of RMA sizes represents outside diameter (inches and 1/8") and recommended rim diameter.

Example: 206 x 35-15 tube dimension is 20 3/4" outside diameter, 35 is 3 3/8" width of tube and 15" rim diameter.



Order No.	RMA Size	Replacement No.	Ship Wt.
41049	181 x 35-12	62F-12.5	9 lbs. - 4 kg
41050	204 x 35-15	62F-15	9 lbs. - 4 kg
41051	214 x 41-16	63F-16	9 lbs. - 4 kg
41174	214 x 56-16	A78-13	10 lbs. - 6 kg
41052	221 x 45-16	65F-16	11 lbs. - 5 kg
41150	230 x 50-16	67F-16, 635-16	13 lbs. - 6 kg
41055	225 x 46-17	67F-17, 68F-17	13 lbs. - 6 kg
41151	237 x 54-17	685-17, 735-17, 233-62-17	13 lbs. - 6 kg
41030	240 x 52-17	704-17	18 lbs. - 8 kg
41163	240 x 64-17	F70-14, 235-65-17	16 lbs. - 7 kg
41192	240 x 80-17	F60-15	19 lbs. - 9 kg
41031	256 x 56-17	754-17	20 lbs. - 9 kg
41033	262 x 60-17	804-17	18 lbs. - 8 kg
41053	241 x 45-18	66F-18, 69F-18	17 lbs. - 8 kg
41166	256 x 66-18	G70-14-18, 243-67-18	19 lbs. - 9 kg
41003	250 x 42-18	76X	14 lbs. - 7 kg
41029	250 x 52-18	704-18	18 lbs. - 8 kg
41183	250 x 66-18	F78-14	19 lbs. - 9 kg
41032	254 x 57-18	754-18, 775-18	17 lbs. - 8 kg
41167	254 x 74-18	G70-15-18, G78-14, 257-75-18, 253-71-18	23 lbs. - 10 kg
41007	260 x 44-18	82X	16 lbs. - 7 kg
41034	260 x 60-18	804-18, 815-18	21 lbs. - 5 kg
41155	260 x 66-18	845-18	18 lbs. - 8 kg
41185	260 x 72-18	H78-14	19 lbs. - 9 kg
41156	264 x 72-18	885-18	23 lbs. - 11 kg
41035	266 x 63-18	854-18	22 lbs. - 10 kg
41157	271 x 75-18	915-18	23 lbs. - 11 kg
41036	272 x 62-18	904-18	16 lbs. - 7 kg
41158	275 x 80-18	905-18	22 lbs. - 10 kg
41002	280 x 52-18	73X, 74X	17 lbs. - 8 kg
41037	280 x 66-18	954-18	23 lbs. - 11 kg
41401	254 x 72-19	875-16.5	21 lbs. - 10 kg
41004	262 x 43-19	77X	14 lbs. - 7 kg
41402	264 x 76-19	950-16.5	24 lbs. - 11 kg
41008	270 x 41-19	80X, 83X	20 lbs. - 9 kg
41011	280 x 52-19	92X	20 lbs. - 9 kg
41406	280 x 101-19	1200-16.5	36 lbs. - 16 kg
41014	292 x 56-19	114X	21 lbs. - 10 kg
41009	282 x 52-20	84X	21 lbs. - 10 kg
41250	280 x 56-20	300X	20 lbs. - 9 kg
41015	290 x 56-20	116X	20 lbs. - 9 kg
41252	295 x 57-22	303X	22 lbs. - 10 kg
41254	306 x 60-22	307X	25 lbs. - 11 kg

Adapter Extension

- For full circle curing tubes

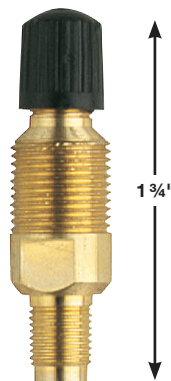

Order No.	Mfr. No.	Description
44440	888	Curing Valve Extension

Order No.	RMA Size	Replacement No.	Ship Wt.
41276	286 x 71-22	325X	25 lbs. - 11 kg
41375	336 x 73-25 1/4	320XXX	33 lbs. - 15 kg
41255	340 x 60-25 1/4	310X	25 lbs. - 11 kg
41256	352 x 66-25 1/4	320X	25 lbs. - 11 kg
41376	354 x 82-25 1/4	330XXX	45 lbs. - 21 kg
41258	364 x 76-25 1/4	330X	31 lbs. - 14 kg
41377	370 x 90-26 1/4	340XXX	42 lbs. - 18 kg
41261	380 x 76-26 1/4	340X, 340XL	37 lbs. - 17 kg
41249	380 x 76-26 1/4	340HDXL	44 lbs. - 20 kg
41263	394 x 84-26 1/4	225, 350X	45 lbs. - 20 kg
41273	380 x 90-28 1/4	11-22.5	40 lbs. - 18 kg
41378	390 x 90-28 1/4	342XXX	47 lbs. - 21 kg
41491	390 x 114-28 1/4	AC46-16	47 lbs. - 21 kg
41262	400 x 80-28 1/4	342X	45 lbs. - 26 kg
41264	414 x 84-28 1/4	352X	44 lbs. - 20 kg
41275	400 x 90-30 1/4	11-24.5	50 lbs. - 23 kg
41265	434 x 84-30 1/4	354X	55 lbs. - 25 kg
41266	422 x 100-30 1/4	364X	67 lbs. - 31 kg
41269	463 x 104-30 1/4	373X	73 lbs. - 33 kg
41478	370 x 80-31	440B	41 lbs. - 19 kg
41479	393 x 81-33	442B	43 lbs. - 20 kg
41481	404 x 85-33	452B	47 lbs. - 22 kg
41268	468 x 106-33	369X	60 lbs. - 28 kg
41270	470 x 120-33	374X	74 lbs. - 34 kg

STONER Spray Lube

- Dual range release



Provides for fast, easy removal from molds. Contains no Class I or Class II ozone depleting substances, no CFC or HCFC propellants, and no chlorinated solvents. Colorless and non-staining 12 Oz. aerosol.

Order No.	Mfr. No.	Description
45215	E218	Heavy-Duty Silicone Release

MYERS Mold Lubricant

- Available in 5-gallon pails, contact us



Concentrated, dilutes up to 40:1 with water and applied with spray or brush. Leaves no carbon deposit. Non-flammable, no unpleasant odor.

Order No.	Mfr. No.	Description	Ship Wt.
45211	D245	1 Gal. Mold Lubricant	10 lbs. - 5 kg

Tubeless Tire Tester



Reduce separation adjustments as much as 90%. Insert needle under surface cover near bead or casing. Air forced into cord body of tire makes any existing separations visible.

Order No.	Mfr. No.	Description
56154	SE6-58T	Tubeless Tire Tester
56156	SE6-58C	Replacement Needle 1/2"
56158	SE6-58D	Replacement Needle 3/4"

Multi-Station Digital Thermocouple

- Efficiently monitors
- Multiple thermocouples

Cost saving and compact combination for virtually instant temperature measurement and monitoring of up to five multiple thermocouples. Totally enclosed and fully wired. Male plugs are re-usable. Features separate battery compartment, low battery alert, peak hold with memory and steel case with cover. Specs.: -30° to 700°F temperature range, 1/2 Rd. second response; 1/2" liquid crystal display.



Order No.	Mfr. No.	Description	Ship Wt.
46846	ATK-TC	Type "K" Multi-Station Pyrometer	4 lbs. - 2 kg
46843	26-K	"K" Thermocouple Wire (Per Ft.) - Not Included	
46844	TPC-K	Male Plug - Not Included	

RAYTEK Infrared Non-Contact Thermometer

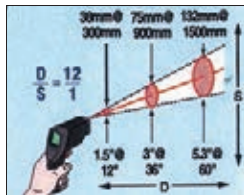

Target Spot Sizes D:S = 12:1 at Focus Point



For automotive and truck diagnostic work on engines, air conditioning, brake inspection, and tire monitoring. Simply point, activate and read. Reads a 1 1/2" target at 12". The 8 point laser measures -25° to 950°F. Rubber casing protects the laser from rough handling. Accurate to +/- 1°. Includes 9V alkaline NiCad battery.

Order No.	Mfr. No.	Description	Ship Wt.
04097	ST30	Infrared Thermometer	1 lbs. - 1 kg

High Heat Chamber Paint

Specially formulated high heat aluminum curing chamber paint. Use as a regular part of the chamber maintenance cycle. TIP: Approximately 2-gallons required for a 22-tire chamber. For best results use a brush.

Order No.	Description	Size	Ship Wt.
45170	High Heat Chamber Paint	1 Gal.	9 lbs. - 4 kg



MYERS Durometer "A" Type

A pocket size durometer with a large easy-to-read dial. Measures hardness by the deflection of a steel probe into the material showing possible process errors. Extremely accurate quality control instrument. Nickel plated brass case in suede-like pouch.



Order No.	Mfr. No.	Description	Ship Wt.
46728	DM	Durometer	1 lbs. - 1 kg

Digital Pyrometer



Offers a F° or C° option switch and a temperature range of 0° to +1,700°F / -18°C to +425°C, accurate to 1°. AV battery has a 1 year life. Features a low battery alert. A needle and surface probe are available, equipped with a flexible lead wire and plug to connect pyrometer. Kit includes Needle Probe, 20K thermocouple wire, 2 male plugs and plastic case.

Order No.	Mfr. No.	Description	Ship Wt.
46839	E-Z	Pyrometer Kit Complete	2 lbs. - 1 kg

Replacement Parts

46859	EZKC	DP II Pyrometer Only
46855	FKTMSN-K2	Needle Probe 1-7/8" Long, .059 Dia.
46857	SS-12KM	Surface Probe
46843	TWK-02629FD2P	"K." Thermocouple Wire (Per Foot)
46844	TPC-K	Male Plug

Tire Painting Mitt

- Use with acid-proof glove

Not affected by solvents. Heavy synthetic fleece mitt with knit cuff. Use with 45333 Neoprene gloves to keep hands clean.

Order No.	Mfr. No	Description
46420	PE9-TXL	Tire Paint Mitt



Acid-Proof Gloves

Neoprene covered gloves with knit wrist for cleaning matrices, painting, etc.

Order No.	Mfr. No	Description
45333	PLNE47KW-L	Acid Proof Gloves



MYERS Black Tire Paint Water Base Concentrate

- No solvents
- No fire hazards

Non-flammable, non-toxic water base latex paint dries in 30 minutes to a pleasing jet black satin finish. Dilute 1 to 1 with water, or mix 1 part water to 4 parts paint for maximum shine. Spray, brush or swab. Covers crayon and chalk marks. Flash point exceeds 200°F.



Order No.	Size	Description	Ship Wt.
46432	1-Gal.	Black Tire Paint	12 lbs. - 6 kg
46434	5-Gal.	Black Tire Paint	45 lbs. - 21 kg
46435	50-Gal.	Black Tire Paint	495 lbs. - 223 kg

MYERS Black Tire Paint Water Base Ready-To-Use



46430



46431

Provides superior coverage and more tires per gallon. Ideal for high volume or smaller plants spraying or hand painting. Apply as is, with a brush, mitt, or spray, to a clean, dry surface. Works well with all types of automatic painters.

Order No.	Size	Description	Ship Wt.
46430	5-Gal.	Black Tire Paint	45 lbs. - 21 kg
46431	50-Gal.	Black Tire Paint	495 lbs. - 223 kg
46491	50-Gal., Fiber Drum	Black Tire Paint	495 lbs. - 223 kg

PATCH RUBBER Restore Tire Paint

- Returns tires to like new appearance
- Fast drying, matte finish
- Ready to use

Contains no solvents or carcinogens. Clean up with soap and water. Restore Tire Paint contains no hazardous volatile compounds. Open the can, agitate, and use. No mixing flammable solvents. Apply with a brush, mitt or sprayer. Restore Tire Paint is formulated to cover on the first coat and the matte finish makes tires look like new. Mix thoroughly before use and agitate during use.



Order No.	Size	Description	Ship Wt.
16365	5-Gal.	Restore Tire Paint	45 lbs. - 20 kg
16366	54-Gal.	Restore Tire Paint	510 lbs. - 231 kg

ATEC Final Touch Water Base Tire Paint

Formulated for the ATEC Model-11 tire inspection/paint machine. Micro size grade of pigment sprays without clogging tips. Premixed and no dilution is necessary. Non-flammable, non-hazardous, nontoxic and approved by the South Coast Air Quality of California. May be used with other sprayers.



Order No.	Mfr. No.	Description	Ship Wt.
45210	WB-10	Tire Paint - 55-Gallon	540 lbs. - 240 kg
45224	WB-10	Paint - 55-Gallon Fiber Drum	540 lbs. - 240 kg
45212	WB-10-5	Tire Paint - 5-Gallon	45 lbs. - 22 kg
45219	WB-10	Non-Skid Tire Paint - 55-Gallon	540 lbs. - 240 kg

MYERS "New Look" Water Base Black Tire Paint

Give retreads and repaired tires a semi-dull new tire look. "New Look" can be sprayed or brushed. Dries in 20 minutes at room temperature. Covers all chalk marks. Avoid freezing and extreme heat. **Note:** The 27.5 gallons of concentrate is delivered in a 55-gallon drum. Fill drum with water and stir thoroughly.



Order No.	Size	Description	Ship Wt.
46050	5-Gal.	New Look Tire Paint	45 lbs. - 22 kg
46049	55-Gal.	New Look Tire Paint	535 lbs. - 241 kg

MYERS Concentrated Black Tire Stain Solvent Base

- Provides a genuine factory finish

One coat brushed or sprayed on a tire gives it an original factory finish. One gallon makes 5 to 9 gallons of tire paint when diluted with gasoline or solvent. **Caution:** Combustible mixture. Observe label precautions. Flash point 105°.



Order No.	Size	Description	Ship Wt.
46400	1-Gallon	Black Tire Dressing	10 kg - 5 kg
46401	5-Gallon	Black Tire Dressing	45 kg - 21 kg
46403	55-Gallon	Black Tire Dressing	480 kg - 216 kg

MYERS Ready-to-Use Black Tire Stain Solvent Base

Permanent black dye to convert whitewalls to blackwalls. Will not scuff off. Apply with a brush, ready-to-use. Covers completely. Flash point 40°.



Order No.	Size	Description	Ship Wt.
46410	1-Gallon	Black Tire Stain	10 lbs. - 5 kg
46411	5-Gallon	Black Tire Stain	45 lbs. - 21 kg
46412	50-Gallon	Black Tire Stain	495 lbs. - 223 kg

Economy Tire Paint Sprayer

- Sprays water or solvent base paints

Designed for fast and easy spraying anywhere in the plant. Tank holds 2½ gallons of paint: solvent or water based. Includes pressure regulator, air and paint hoses, spray gun, and paint tank rated for 80 psi.



Order No.	Mfr. No.	Description	Ship Wt.
56090	TP-3	Myers Tire Painter	20 lbs. - 9 kg
56091		Replacement Gun	3 lbs. - 2 kg

Tire Regroovers

RILLFIT VI-R Regrooving Tool

- The professionals choice for fast, controlled tire grooving



Parts list on 85

Designed for operating comfort and maximum grooving maneuverability. The Micro-Switch controlled cutting heads need only a slight amount of pressure to activate the heating element. Features an adjustable 4 step transformer corresponding to blade resistance value.

Order No.	Description	Ship Wt.
93233	Rillfit VI-R Regroover, 110V	11 lbs. - 5 kg
93234	Rillfit VI-R Regroover, 220V	11 lbs. - 5 kg

Round Blades					Flat Blades				
Order No.	Mfr. Code	Cutting Width Inches	mm	Blades Per Pk.	Order No.	Mfr. Code	Cutting Width Inches	mm	Blades Per Pk.
93211	R-1	3/4"	2	20	93216	W-1	3/4"	2	20
93212	R-2	1/2"	3	20	93217	W-2	5/8"	4	20
93213	R-3	13/64"	5	20	93218	W-3	1/4"	6	20
93214	R-4	9/32"	7	20	93219	W-4	5/16"	8	20
93215	R-5	7/64"	9	20	93220	W-5	13/32"	10	20
					93221	W-6	7/8"	22	20

IDEAL Tire Regroovers



Ideal Regroovers heat the rubber ahead of cutting blade. Blade is adjustable for depth. Includes No. TG-4 Head and 12 No. TG-4B Blades. Specify 110 or 220V, and 150 or 250 watt element.

Order No.	Mfr. No.	Description	Watt Element	Ship Wt.
42887	TG-115D	Straight Handle 110V	250	2 lbs. - 1 kg
42835	TG-125D	Pistol Grip 110V	250	2 lbs. - 1 kg
42878	TG-125D	Pistol Grip 220V	250	2 lbs. - 1 kg

Ideal Regroover Blades

Standard Round End					Standard Square End				
Order No.	Mfr. No.	Grove In.	Blades Per Pkg.		Order No.	Mfr. No.	Grove In.	Blades Per Pkg.	
42859	TG-2B	3/32"	12		42870	TG-3BS	5/32"	12	
42860	TG-3B	1/32"	12		42871	TG-4BS	7/32"	12	
42861	TG-4B	7/32"	12		42872	TG-5BS	5/32"	12	
42862	TG-5B	9/32"	12						
Large Square End					Super Round End Blades				
42863	TG-6B	3/8"	12		42880	TG-3BB	5/32"	12	
42864	TG-8B	1/2"	12		42881	TG-4BB	7/32"	12	
42865	TG-10B	5/8"	12		42882	TG-5BB	5/32"	12	
42866	TG-12B	3/4"	12		Super Square End Blades				
					42883	TG-6BB	3/8"	12	

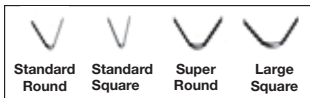

Ideal Groover Heads

Separate head required for each blade size.

Order No.	Mfr. No.	Grove In.
42842	TG-1H Head	1/16"
42843	TG-2H Head	3/32"
42844	TG-3H Head	5/32"
42845	TG-4H Head	7/32"
42846	TG-5H Head	9/32"
42847	TG-6H Head	3/8"
42848	TG-8H Head	1/2"
42849	TG-10H Head	5/8"
42850	TG-12H Head	3/4"

Groover Blades Sharpening File		
Order No.	Mfr. No.	Description
42898	TG-5	Small Round File
42899	TG-5A	Small Half Round File

MYERS G1000HL Regroover



- Made in the U.S.A
- Premium heavy-duty grooving blades



Designed for operating comfort and maximum grooving maneuverability. Features a stainless steel case and four power heat settings. A teflon guide block assures a smooth cutting action. Blades are changed quickly and easily. The "thicker" blade design is tapered for a wide top where strength is needed and a thinner bottom reducing cutting drag. Includes regroover and (2) each #4GF, #6GF, #8GF, and #10GF blades.

Order No.	Description	Ship Wt.
93230	Myers G1000 Regroover 110V	11 5
93232	Myers G1000 Regroover, 220V	11 5

Round Bottom Blades					Flat Bottom Blades				
Order No.	Mfr. Code	Cutting Width Inches	Depth	Blades Per Pk.	Order No.	Mfr. Code	Cutting Width Inches	Depth	Blades Per Pk.
48444	8 GR	1/4"	7/16"	12	48438	4 GF	1/8"	7/16"	12
48445	10 GR	5/16"	7/16"	12	48439	6 GF	3/16"	7/16"	12
					48440	8 GF	1/4"	7/16"	12
					48441	10 GF	5/16"	7/16"	12
					48442	12 GF	3/8"	7/16"	12
					48443	14 GF	7/16"	7/16"	12
					48515	16 GF	1/2"	7/16"	12

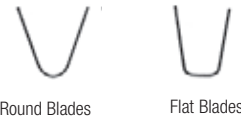

Note: Other blade sizes available up to 32/32" wide.

K-Z Regroover

- Universal cutting head
- Push-Type with fully automatic blade cutting
- 3-Step heat control



Blade holder is adjustable in 7 steps from 3/32" to 13/16" (2-28mm). The new method of blade insertion guarantees positive electrical contact and heat transfer. Air gap insulation between the two cutting head halves eliminates short circuits. Reinforced transformer has 3 heat control settings. Unbreakable plastic housing is fully insulated to meet regulations of the International Electro-Technical Commission.

Order No.	Mfr. No.	Description	Ship Wt.
42802	KZ-6	110V Regroover	5 lbs. - 2 kg
42686	KZ-6	220V Regroover	11 lbs. - 5 kg

For Passenger and Truck Tires V-Shaped Cutting Blades

Order No.	Mfr. No.	Cutting Width In.	Cutting Depth Up to In.	Blades Per Pk.
42825	KZ-101	3/32"-3/16"	5/16"	20
42826	KZ-102	3/16"-9/32"	5/16"	20
42827	KZ-103	9/32"-5/16"	7/16"	20
42828	KZ-104	5/16"-7/16"	9/16"	20
42829	KZ-105	7/16"-9/16"	5/8"	20
42837	KZ-106	5/8"-11/16"	5/8"	20

For Grader and EM Tires

42824	KZ-110	1 1/16"-13/16"	5/8"	20
-------	--------	----------------	------	----

Caution: Genuine KZ Blades must be used with the KZ Regroover

ELRICK #32A Brander with 1" Numbering Disc

- Single slot for 1" letters



Support Handle gives more positive control, reduces fatigue and errors.



45699
45741

Slot holds three 1" replaceable numbers and letters.



Dial-The-Number Indicator shows number being branded.



45601

Parts list on page 83

Specially designed 1000W heating element reaches branding temperature faster (approx. 10 min.) and holds temperature. Hardwood handle. Special high heat conducting alloy number head and letter inserts for longer branding usage. Separate replaceable heating element, no need to replace number disc with element as with other branders. Built-in stand allows user to set hot tool almost anywhere. Both models feature a 1" numbering disc. The Branders include a 10' extension cord and a short handle for easier branding. Available in 110 and 240 volt. Specify voltage.

NOTE: Single Slot Brander holds up to three 1" characters.

Order No.	Mfr. No.	Description	Ship Wt.
45699	32A	Single Slot Brander 110V	11 lbs. - 5 kg
45741	32A	Single Slot Brander 240V	11 lbs. - 5 kg
45601		Timer	11 lbs. - 5 kg

ELRICK Stop Spacers & Blank Spaces

If the maximum allowed characters for the brander head are not used, a blank space "character" or stop spacer is needed to hold the characters in place.

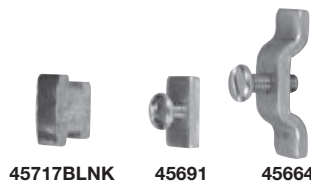

Order No.	Description
45691	Stop Spacer for 1/4" & 1/2" Brander Head
45664	Stop Spacer for 1" Brander Head
45712BLNK	1/4" Blank Space
45717BLNK	1/2" Blank Space
45701BLNK	1" Blank Space for #32 Brander Only

ELRICK #16E Brander for 1/2", 1/4" & 3/8" Characters



Parts list on page 84

Built-in stand allows hot tool to be set almost anywhere. Brander head features a "T" slot for inserting up to (14) 1/4", (12) 3/8" or (7) 1/2" characters. Set screws in the head hold the maximum amount of characters without using a stop spacer. Characters can be inserted in a hot tool using pliers. Letters and numbers sold separately. 15" Long from head to start of cord. Replaceable heating element. Includes 12' cord. Available in 110V or 220 v.

Order No.	Mfr. No.	Description	Ship Wt.
45840	16E	Brander 110V	6 lbs. - 3 kg
45841	16E	Brander 220V	6 lbs. - 3 kg
45601		Timer	2 lbs. - 1 kg

Recommended for use with a 16 gauge extension cord

ELRICK Letter & Number Sets for Tire Branders

Actual Size 1/4" 3/8" 1/2" 1"

Order No.	Letter Size	Description	Ship Wt.
45737	1/4"	A Thru Z Set	2 lbs. - 1 kg
45726	3/8"	A Thru Z Set	2 lbs. - 1 kg
45735	1/2"	A Thru Z Set	2 lbs. - 1 kg
45733	1"	A Thru Z Set	3 lbs. - 2 kg
45731	1/4"	0 Thru 9 Set	1 lbs. - 1 kg
45729	1/2"	0 Thru 9 Set	1 lbs. - 1 kg
45727	1"	0 Thru 9 Set	2 lbs. - 1 kg

Individual Letters & Numbers (Specify Each A-Z or 0-9) Example: 45712A

45712	1/4"	A-Z, 0-9 (Specify)
45705	3/8"	A-Z, 0-9 (Specify)
45717	1/2"	A-Z, 0-9 (Specify)
45701	1"	A-Z, 0-9 (Specify)

ELRICK Custom Plates

- For all #16 & #32 branders

Custom-made plate of your company trademark available for insert slot. Send design and sketch for quotation.

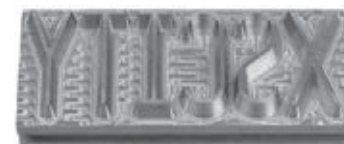

45747 Sample

Order No.	Description
45740	1/2" Custom Branding Insert
45747	1" Custom Branding Insert for #32 Brander Only

MYERS REPAIR SERVICE AVAILABLE ON ALL BRANDERS

Tire Branders

ELRICK #20 Brander Body for Interchangeable Plates

- 1/4", 3/8" & 1/2", or 1" brander in one unit
- Custom brand or logo plates available
- Interchangeable plates sold separately below



Parts list on page 85

The #20 Brander body allows the use of 1/4", 3/8" and 1/2" characters or 1" characters by attaching the desired plate to the brander body with 4 set screws. Order the 1/4" and 1/2" or the 1" plates as required. 4 Set screws included for attaching the plates. Built-in stand allows hot tool to be set almost anywhere. 19" Long from head to start of cord. Includes 12' cord. Available in 110V or 220V.

Order No.	Mfr. No.	Description	Ship Wt.
45787	20	Brander 110V	7 lbs. - 3 kg
45788	20	Brander 220V	7 lbs. - 3 kg
45601		Optional Timer	

Recommended for use with a 16 gauge extension cord.

ELRICK Interchangeable 2" x 4-1/4" Plates for #20 Brander

- 1/4", 3/8" & 1/2" Double slot, or 1" single slot brander plate
- Custom brand or logo plates available
- Includes screws for fastening to #20 brander



45789 Double Slot Holder for 1/4", 3/8" or 1/2" Characters



45790 Single Slot Holder for 1" Characters



Example of 45791 Custom Character Plate



Example of 45792 Custom Design Logo Plate

45789 Double slot plate accommodates any combination of 1/4", 3/8" or 1/2" characters. The plate holds up to 32, 1/4" characters, 16 characters per row; 34, 3/8" characters, 17 characters per row and up to 18, 1/2" characters, 9 characters per row.*

45790 Single slot plate holds any combination of 1" characters, up to 7 characters total.*

45791 Custom Character Plate is permanently engraved plate with any combination of characters. Attaches to #20 brander with set-screws.

45792 Custom Design Plate is a permanently engraved plate of your company logo, trademark, or symbol. Attaches to #20 brander with set-screws.

* **NOTE:** When using less than the maximum number of characters a stop spacer must be used. See page 326 for complete listing of stop spacers.

Order No.	Description
45789	Double Slot Holder for 1/4", 3/8" & 1/2" Characters
45790	Single Slot Holder for 1" Characters
45791	Custom Character Plate (Letters or Numbers)
45792	Custom Design Plate (Logo)

ATEC Insta/Spect-I Inspection/Painting Station



Use for repair, initial or final inspection. Two 4" lifting cylinders raise a 300 lb. tire at 125 psi. A separate 4" cylinder spreads tire beads. Options include an attached Tire Paint/Finishing machine and an airless pump with automatic spray guns. Automatically adjusts from 26" to 46" diameter x 20" cross section. Diameters can be modified for larger or smaller sizes. 4 HP air motor. Requires 125 psi, 1/2" air inlet.

Order No.	Description	Ship Wt.
45226	Model 115 Insta/Spect-1 with Light Package	750 lbs. - 338 kg

Sealing Ring Installation Stand

- Must specify monorail height when ordering



Sealing ring installation station is installed under the monorail. Raises to lift tire off the "J" hook and allows for the installation of sealing rings. **Note:** Specify monorail height before ordering.

Order No.	Description	Ship Wt.
36596	Sealing Ring Installation Stand	250 lbs. - 113 kg

Traveling Cable Lift Cylinder

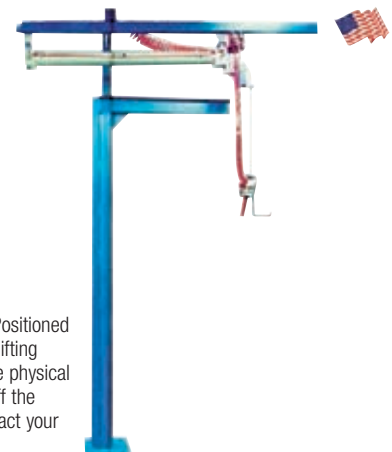

Complete with Support and Track: Positioned over buffers and builders, used for lifting tires on and off expanding rims. The physical effort of lifting heavy tires on and off the builder or buffer is eliminated. Contact your Myers Sales Rep for details.

Order No.	Description	Ship Wt.
36594	Traveling Cable Lift Cylinder, Includes Base, Post, Track with Wheels for 7' High Monorail	300 lbs. - 115 kg

Monorail Track & Support

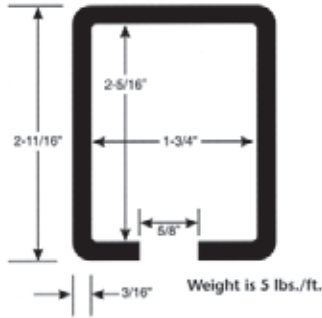

Track sold in 10' sections and configurations. Removable monorail section (36589) moves tires inside the curing chamber allowing the door to close.

Order No.	Description	Ship Wt.
36584	10' Straight Track	50 lbs. - 23 kg
36587	Track 45° Curve x 24" Radius with 8" Extension	35 lbs. - 16 kg
36586	Track 90° Curve x 24" Radius with 8" Extensions	35 lbs. - 16 kg
36589	Removable Chamber Door Monorail Lift Out Section	35 lbs. - 16 kg

Monorail Track Supports

36581	Single Standard Monorail Support	125 lbs. - 57 kg
36580	Double Monorail Support	180 lbs. - 81 kg
36579	Triple Monorail Support	250 lbs. - 113 kg
36582	90° Corner Monorail Support	170 lbs. - 77 kg

"J" Hooks

This is an accessory to the monorail track. Made from 1" round bar stock this "J" hook fits better than older flat bar "J" hooks, making it more comfortable to handle and easier on beads of tires and envelopes. "J" hooks and trolley assemblies sold separately. Wide base "J" hook handles wide base tires easier.

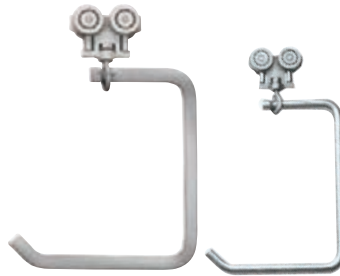

Order No.	Description	Ship Wt.
36571	Four Wheel Trolley Assembly Only with Eye Bolt	10 lbs. - 5 kg
36572	Two Wheel Trolley Assembly 5/8"-11 Thread Stud	
36590	"J" Hook Only - No Trolley Assembly 9" Hanging Area	7 lbs. - 3 kg
36600	Wide Base "J" Hook Only - No Trolley Assembly 16" Hanging Area	8 lbs. - 4 kg

3-Way Monorail "T" Switch



Allows the tire to be directed within the monorail system.

Order No.	Description	Ship Wt.
36575	3-Way Monorail Switch	50 lbs. - 23 kg

Tilt Table



Sealing Ring and Inside Envelope installation station installed under a monorail. Tire is lowered from the "J" hook on to the table where a sealing ring or inside envelope is installed on one side of the tire. Flip tire to the other side for the other sealing ring or tucking flap of the inside envelope under the outside envelope.

Order No.	Description	Ship Wt.
36595	Tilt Table	350 lbs. - 158 kg

Precure Vacuum Envelope Tester

Test duplicates the stress on envelopes during curing. Attach the coupler and an electric vacuum pump removes the air from under the envelope. A green light shows the envelope seal is good when the test is complete. 110v.



Order No.	Description	Ship Wt.
36597	Envelope Tester	85 lbs. - 31 kg

Steam Ball Valves



150 psi saturated steam on/off service. All wetted metallic components brass to resist corrosion. Solid Teflon seats and glass-filled Teflon stem seals. Chromium plated brass ball.

Order No.	Mfr. No.	Description	I.P.T. Size	Ship Wt.
44711	70-101	Steam Ball Valve	3/4"	1 lbs. - 1 kg
44713	70-102	Steam Ball Valve	3/8"	1 lbs. - 1 kg
44712	70-103	Steam Ball Valve	1/2"	1 lbs. - 1 kg
44714	70-104	Steam Ball Valve	3/4"	1 lbs. - 1 kg
44715	70-105	Steam Ball Valve	1"	2 lbs. - 1 kg
44716	70-106	Steam Ball Valve	1 1/4"	3 lbs. - 1 kg
44717	70-107	Steam Ball Valve	1 1/2"	4 lbs. - 2 kg
44718	70-108	Steam Ball Valve	2"	5 lbs. - 2 kg

SARCO Thermodynamic Steam Traps

- 10-600 PSI



3 Stainless steel parts-only one moving part. Self-adjusting trap for 10-600 psi for all loads without adjustment. Freeze-proof when installed with outlet down, free to drain.

Order No.	Mfr. No.	Description	Size
44590	AS-891	Steam Trap	3/8"
44591	AS-892	Steam Trap	1/2"
44592	AS-893	Steam Trap	3/4"
Replacement Slotted Discs			
44587	56631		3/8"
44588	57443		1/2"
44589	56632		3/4"

Y-Strainers

Cast iron construction and designed for working pressure 250 lbs. psi at max. temp. 450° F.



Order No.	Mfr. No.	I.P.T. Size	Ship Wt.
44579	AS-YA	1/2"	1 lbs. - 1 kg
44580	AS-AT	3/8"	1 lbs. - 1 kg
44581	AS-YB	3/4"	2 lbs. - 1 kg

Check Valve

A perfectly sealed, leakproof, virtually maintenance free valve. Quick opening-positive closing-opens at 1 psi "bubble tight" against back pressure. Brass with 1/4" male connections. 0-250 psi



Order No.	Mfr. No.	Description
44616	22328-2MM	Check Valve

ARMSTRONG Steam Traps

Side inlet steam traps. Series 800 and 880 max. psi 80 lbs. Series 881 max. psi 125 lbs. For draining low and medium pressure, Series 880 has a built-in strainer. (Specify pipe size.)



Order No.	Mfr. No.	Orifice	FTP In.	Ship Wt.
44593	AS-880	1/8"	1/2" or 3/4"	6 lbs. - 3 kg
44595	AS-800	1/8"	1/2" or 3/4"	5 lbs. - 2 kg
44594	AS-881	1/8"	1/2" or 3/4"	6 lbs. - 3 kg

Repair Kit and Replacement Parts

Order No.	Mfr. No.	Description
44635	PCA-881	Repair Kit
44578	A1433	Body Gasket

Steam Reducing Valves

For supply pressure up to 140 lbs., reduced pressure adjustable for 30-140 lbs. Set at 75 lbs. Other ranges available on special order. Female inlet and outlet.



Order No.	Mfr. No.	I.P.T. Size	Ship Wt.
44697	AS-152A	1/2"	6 lbs. - 3 kg
44698	AS-152B	3/4"	12 lbs. - 5 kg
44699	AS152C	1"	19 lbs. - 9 kg

*30-100 Set at 50

Repair Kits for Above Steam Reducing Valves

Includes diaphragm gasket, strainer, bottom plug gasket, stem disc and bushing assembly and diaphragm (set of 3).

Order No.	Mfr. No.	I.P.T. Size	Ship Wt.
44702	152A-RK	1/2"	1 lbs. - 1 kg
44704	152A-RK	3/4"	1 lbs. - 1 kg
44706	152A-RK	1" x 1 1/4"	2 lbs. - 1 kg
44708	152A-RK	1 1/2"	2 lbs. - 1 kg

Boiler Water Treatment

For calcium or magnesium carbonate hardness up to 5 grains per gallon; for excess oxygen and corrosion control. Do not use with food products.



Order No.	Mfr. No.	Description	Ship Wt.
46628	PB677	4-Gallon.	5 lbs. - 2 kg

PARKER Boilers

- 1-1/2 To 150 HP boilers available
- Return systems & blowdown tanks sized to your requirements
- Contact your local Myers Sales Office

Compact design and quality construction assures reliable, long life service in less space per hp than conventional designs with comparative heating surfaces. Easily accessible internal boiler drum, tubes and burners. Individual reversible tube sections. Less than 10 minutes required to generate 80 lbs. of steam from a cold start. Virtually explosion-free double welded boiler construction. Fully automatic controls. Low installation cost, economical operation, inexpensive to maintain, and easy to clean.

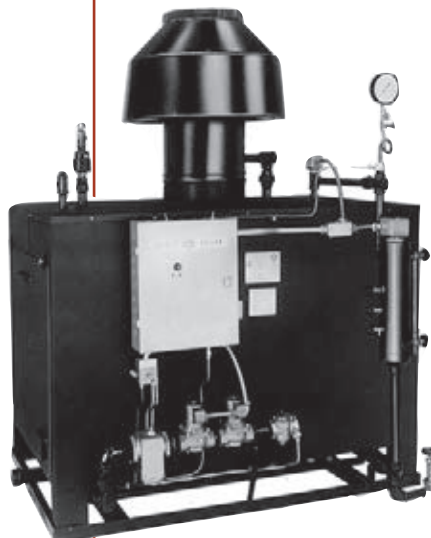

COMPAIR L-Series Lubricating Rotary Screw Air Compressors

- 30 to 150 HP models available
- 100, 125 & 190 Working psi available
- 195 CFM to 729 CFM available depending on hp & psi configuration
- Contact your local Myers sales office



Siphon for Steam Gauge

Straight pattern, 1/4" pipe, 4 3/8" long. Wrought steel for 475 lbs., 750° F.



Order No.	Mfr. No.	Description
44732	AS-S1	Siphon

Slic-Tite Pipe Thread Tape

High-density 1/2" x 300" roll



Order No.	Description
46157	Pipe Thread Tape

ELRICK #16 & #16B Brander

- ½" Brander manufactured before Jan. 2005

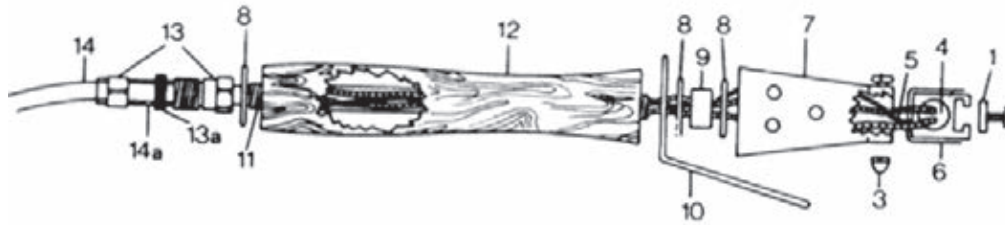

Picture No.	Order No.	Description	Qty. Req.
1	45691	Stop Spacer	2
4a	45695	120V Heating Element	1
4b	45667	220V Heating Element	1

Picture No.	Order No.	Description	Qty. Req.
6	45620	Insulator Gasket	1
8	45624	½" Washer	1
9	45626	Bushing	1
11	45628	Threaded Pipe	1
12	45694	Handle Grip	1

Picture No.	Order No.	Description	Qty. Req.
13	45630	Clamping Nut	1
14	45696	14" Cord	1
14a	45629	Nut	1

ELRICK #16C Brander

- ½" Brander manufactured after Jan. 2005

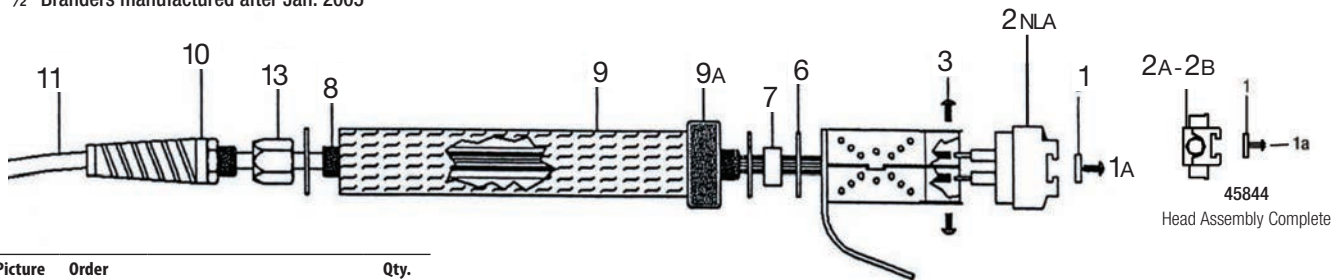

Picture No.	Order No.	Description	Qty. Req.
1	45793	Stop Spacer w/ Screw	2
1A	45794	Stop Screw Only	1
2A	45844	110V Head Assembly Complete (Incl. 2A, 2B, 2C, 2D & 3)	1
2B	45833	220V Head Assembly Complete (Incl. 2A, 2B, 2C, 2D & 3)	1
3	45796	Head Screws	

Picture No.	Order No.	Description	Qty. Req.
6	45797	1 ½" Washer	1
7	45798	Bushing	1
8	45799	Threaded Pipe	1
9	45800	Handle Grip	1
9A	45801	Handle Guard	1

Picture No.	Order No.	Description	Qty. Req.
10	45802	Strain Relief Assembly	1
11	45803	Electric Cord Assembly	1
13	45804	Coupling Nut	1

ELRICK #32A 1" Brander

- See page 79 for product details

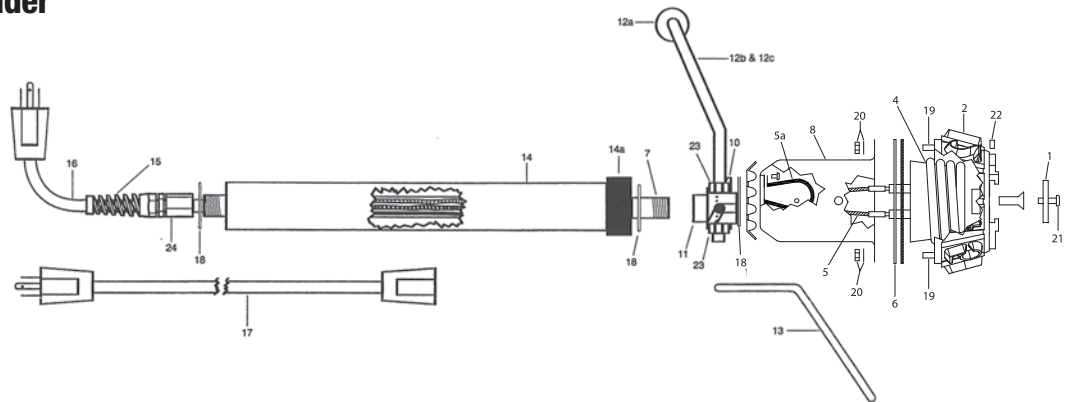

Picture No.	Order No.	Description	Qty. Req.
1	45664	Stop Spacer	1
2	45613	Branding Head (Incl Gasket & Nuts)	1
4A	45617	110V Heater Repl. Kit (Incl. Heater, Gasket, Nuts & Instructions")	1
4B	45614	220V Heater Repl. Kit (Incl. Heater, Gasket, Nuts & Instructions")	1
6	45623	Gasket	1
7	45625	Pipe	1
8	45675	Case Housing & Dial	1

Picture No.	Order No.	Description	Qty. Req.
10	45677	Indicator Bushing	1
11	45678	Inner Bushing	1
12	45679	Support Handle (Complete)	1
12a	45642	Wood Handle	1
12b	45644	Wire - Right	1
12c	45646	Wire - Left	1
13	45684	Wire Stand	1
14	45627	Wood Grip Handle	1
15	45629	Clamping Nut	1

Picture No.	Order No.	Description	Qty. Req.
16	45633	16" Cord	1
17	45637	10' Extension Cord	1
18	45688	1-½" Washer	1
19	45689	Head Stud	1
20	45639	Head Nut with Washer	1
21	45685	Screw/Stop Spacer	2
22	45640	Slot Screw	1
23	45654	Nut/Support Handle	2
24	45629	Coupling Nut	1

Parts Breakdown

ELRICK #16D Brander

- ½" Brander manufactured after Jan. 2005

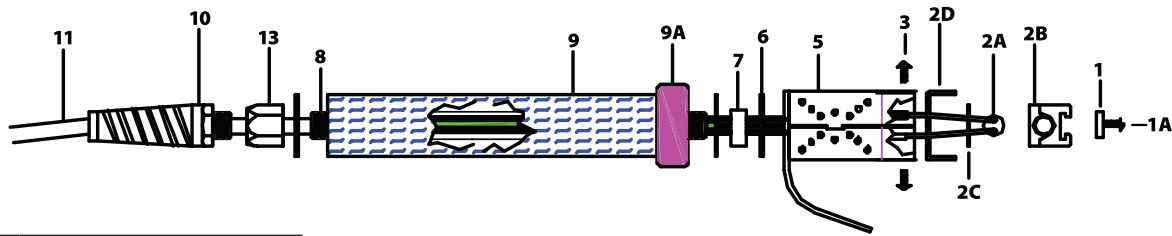

Picture No.	Order No.	Description	Qty. Req.
1	45793	Stop Spacer	2
1A	45794	Stop Screw	1
2	45844	110V Head Assembly Complete (Incl. 2A, 2B, 2C, 2D & 3)	1
2	45833	220V Head Assembly Complete (Incl. 2A, 2B, 2C, 2D & 3)	1
2A	45835	110V Heating Element	1
2A	45836	220V Heating Element	1
2B	45846	Branding Head Only	1

Picture No.	Order No.	Description	Qty. Req.
2C	45837	Head Gasket	1
2D	-	Head Bracket	1
3	45796	Head Screws	1
6	45797	1 ½" Washer	1
7	45798	Bushing	1
8	45799	Threaded Pipe	1

Picture No.	Order No.	Description	Qty. Req.
9	45800	Handle Grip	1
9A	45801	Handle Guard	1
10	45802	Strain Relief Assembly	1
11	45838	Electric Cord Assembly	1
13	45804	Coupling Nut	1

ELRICK #16E Brander

- See page 84 for product details

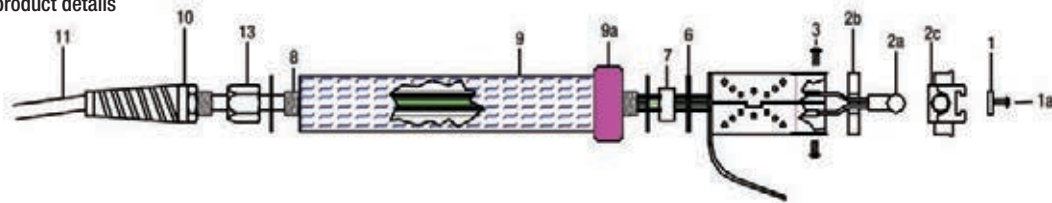

Picture No.	Order No.	Description	Qty. Req.
1	45793	Stop Spacer	2
1A	45794	Stop Screw	1
2	45844	110V Head Assembly Complete (Incl. 2A, 2B, 2C, 2D & 3)	1
2	45845	220V Head Assembly Complete (Incl. 2A, 2B, 2C, 2D & 3)	1
2A	45835	110V Heating Element	1
2A	45836	220V Heating Element	1

Picture No.	Order No.	Description	Qty. Req.
2B	45847	Deflector Guard	1
2B	45846	Branding Head Only	1
3	45796	Head Screws	1
6	45797	1 ½" Washer	1
7	45798	Bushing	1
8	45799	Threaded Pipe	1

Picture No.	Order No.	Description	Qty. Req.
9	45800	Handle Grip	1
9A	45801	Handle Guard	1
10	45802	Strain Relief Assembly	1
11	45838	Electric Cord Assembly	1
13	45804	Coupling Nut	1

ELRICK #32 1" Brander

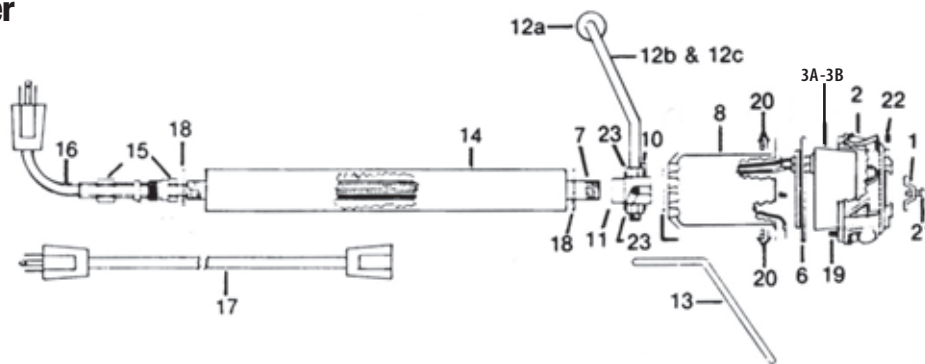

Picture No.	Order No.	Description	Qty. Req.
1	45664	Stop Spacer	1
2	45613	Branding Head (Incl. Gasket & Nuts)	1
3A	45617	110V Heater Repl. Kit (Incl. Heater, Gasket, Nuts & Instructions")	1
3B	45614	220V Heater Repl. Kit	1
6	45623	Gasket	1
7	45625	Pipe	1
8	45675	Case Housing & Dial	1

Picture No.	Order No.	Description	Qty. Req.
10	45677	Indicator Bushing	1
11	45678	Inner Bushing	1
12	45679	Support Handle (Complete)	1
12a	45642	Wood Handle	1
12b	45644	Wire - Right	1
12c	45646	Wire - Left	1
13	45684	Wire Stand	1
14	45627	Wood Grip Handle	1
15	45629	Clamping Nut	1

Picture No.	Order No.	Description	Qty. Req.
16	45633	16" Cord	1
17	45637	10' Extension Cord	1
18	45688	1-½" Washer	1
19	45689	Head Stud	1
20	45639	Head Nut with Washer	1
21	45685	Screw/Stop Spacer	2
22	45640	Slot Screw	1
23	45654	Nut/Support Handle	1

ELRICK #20 Brander

• See page 80 for product details

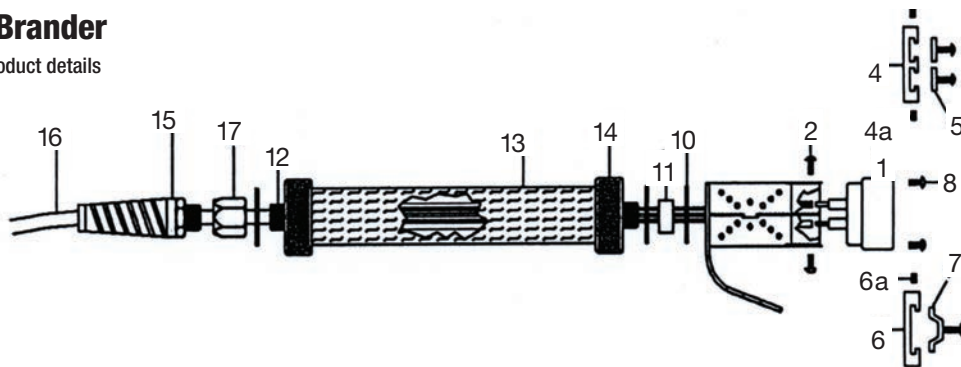

Picture No.	Order No.	Description	Qty. Req.
1A	45824	110V Element Head	1
1B	45806	2200V Element Head	1
2	45807	Head Fasteners	1
4	45789	Double Slot Plate	1
4A	45809	Double Slot Screw	1
5	45810	Double Slot Stop Spacers	2

Picture No.	Order No.	Description	Qty. Req.
6	45790	Single Slot Plate	1
6A	45812	Single Slot Screw	1
7	45813	Single Slot Stop Spacers	2
8	45814	Plate Fasteners	1
10	45815	1/2" Washer	1
11	45816	Bushing	1

Picture No.	Order No.	Description	Qty. Req.
12	45817	Threaded Pipe	1
13	45818	Handle Grip	1
14	45819	Handle Guard	1
15	45820	Strain Relief Assembly	1
16	45821	Electric Cord Assembly	1
17	45822	Coupling Nut	1

BRANICK EF & EF/HD Spreaders

• See page 51 for product details

For a complete list of parts, contact your local Myers Sales Professional.

Order No.	Mfr. No.	Description	Qty. Req.
70302	41.015	Piston Cup for EF Lift Cylinder	1
70342	41.295	Piston Cup for EF/HD Lift Cylinder	1
70338	190.014	Piston Cup for EF & EF/HD Diameter Arm Cylinder	1
70342	41.295	3/16" ID Piston Cup for EF Spread Cylinder	1
70204	041.007	2" ID Piston Cup for EF Spread Cylinder	1
70338	190.014	Piston Cup For EF/HD Spread Cylinder	1
Call	190.003	#30 Air Valve 3-Way for Spread & Diameter Arm (Fast) Std.	2
Call	190.279	#48 Air Valve 3-Way for Tire Lift (Slow) Std.	1
Call	190.004	#60 Air Valve 3-Way for Tire Lift (Extra Slow) Older Models	1
70324	110.005	Spread Arm Spring for EF	2
70316	110.002	Spring for EF	2
70332	110.011	Bead Hook Spring for EF/HD	2



RILLFIT Regroover Models IV & VI

• See page 78 for product details

Order No.	Description	Rillfit IV	Rillfit VI	Qty. Req.
93222	Cable from Unit to Handle	X		1
93223	Electric Cord	X		1
93224	Clamping Jaws	X	X	Set
93225	Complete Blade Holder Assembly	X	X	1
93226	Allen Screws	X	X	2
93227	Allen Wrench	X	X	1
93228	Holding Blocks	X	X	2



For a complete list of parts, contact your local Myers Sales Professional.

Parts Breakdown

MYERS Extruder Gun With IR Motor (14975 & 14976)

- See page 17 for product details
- All replacement parts require 1 each

Picture No	Order No.	Description
1*	52989	7803-A Air Drive Motor Only
1A**	49045	7803-A Air Drive Motor Less Chuck with Bushing
2	53140	Tool Cover
3	14987	Tang
4	14986	Square Joint
5	14996	Extruder Screw
6	14955	Clamp with Screw
7	14984	Handle
8	14954	Control Body
9	14953	Guard
10	14952	Head Cap
11	14960	Head Cap Screw
12	14983	Nozzle Adapter
13	14982	Shaped Nozzle

Picture No	Order No.	Description
14	14998	Heat Element 110 V.
15	14981	Heat Element 220 V.
16	14999	Thermostat
17	14974	Control Box
18	14959	Screw for Control Box
19	14958	Screw for Thermostat
20	14980	Knob
21	14964	Green Pilot Light
21A	14963	Red Pilot Light
22	14973	Fuse 4 Amp
23	14985	Fuse Holder/Locking
24	14988	¼" Lead Cord Fitting
25	14989	Cord & Plug
26	14844	Small ID Bushing-7803 Motor
26A	14843	Large ID Bushing-7803 Motor*

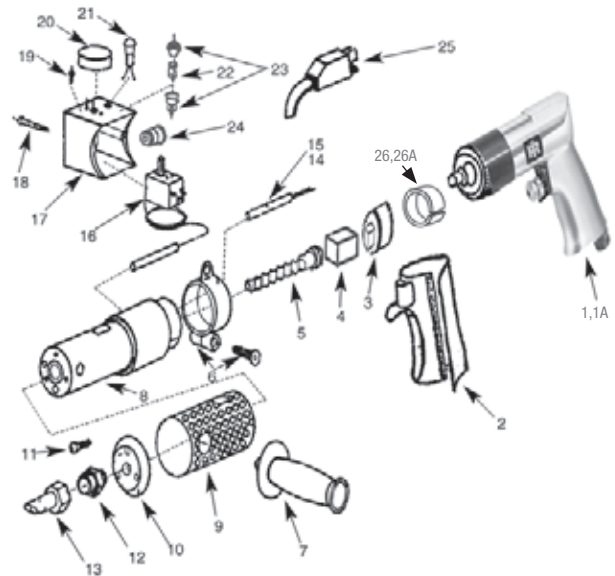

* For extruders purchased after June 2005 ** For extruders purchased before June 2005

MYERS Nailhole Extruder Gun with IR Motor (14977 & 14978)

- See page 17 for product details
- All replacement parts require 1 each

Picture No	Order No.	Description
1	52989	Air Drive motor
2	53140	Tool Cover
3	14979	Extruder Screw
4	14972	Clamp with Screw
5	14971	Handle
6	14970	Control Body
7	14969	Nozzle Adapter
8	14968	Flat, 2mm, 3mm, 4mm, 5mm Dia. Nozzle Set
9	14967	Bottom Cover
10	14957	Grommets w/ screws
11	14998	Heat Element 110V
12	14981	Heat Element 220V

Picture No	Order No.	Description
13	14988	¼" Lead Cord Fitting
14	14966	Heater Body
15	14989	Cord & Plug
16	14965	Heat Box
17	14956	Screws For Heat Box
18	14964	Green Light
19	14980	Thermostat Knob
20	14963	Red Light
21	14962	On/Off Switch
22	14973	Glass Fuse 4 amp
23	14985	Fuse Holder/Locking Nut
24	14999	Thermostat
25	14961	Plastic Thermostat Ring

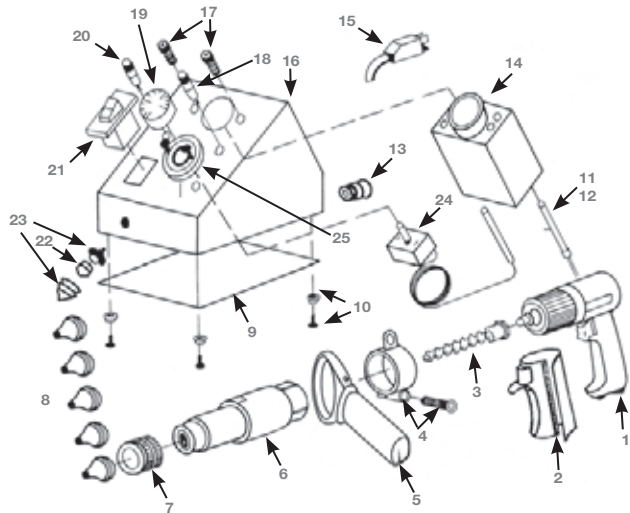

TRIPLEMATIC HSG-48 Extruder Gun

- See page 17 for product details
- All replacement parts require 1 each

Picture No	Mfr. No.	Description
7	6112005	Temp Control 120V
7	6112003	Temp Control 240V
25	0220011	Handle
27	6110080	Bushing 120V
27	6111080	Bushing 240V
28	6110045	Barrel
33	0320948	Cap
34	0410018	Nozzle

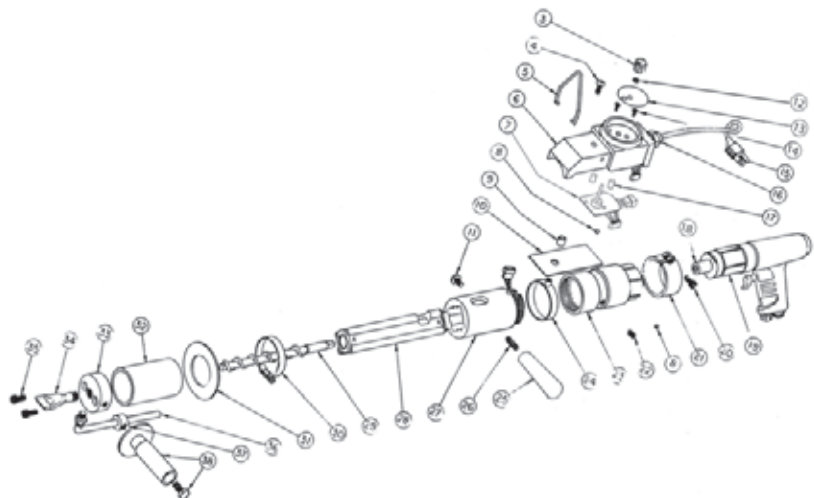

For a complete list of parts, contact your local Myers Sales Professional.

Extruder Gun with Bosch Air Motor (15002)

- Note: Ingersoll-Rand Retro Kit available. Contact your local Myers Sales Professional
- See page 17 for product details

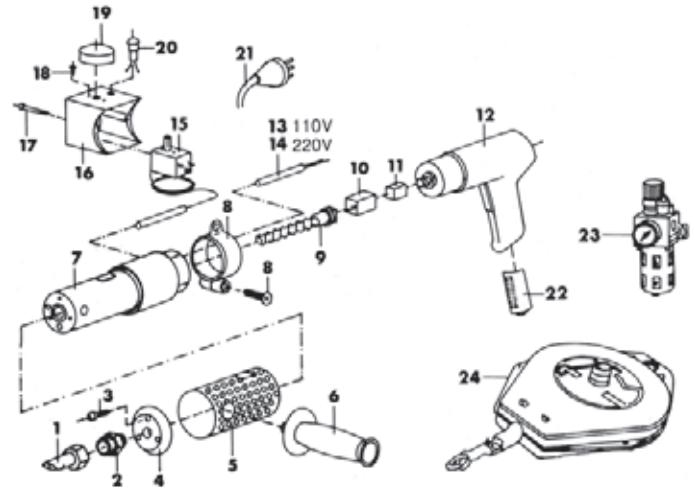

Picture No.	Order No.	Mfr. No.	Description	Qty. Req.
1	14847	68501	Shaped Nozzle	1
2	14846	68502	Nozzle Adapter	1
3	14960	68503	Screw/Head Cap	1
4	14944	68504	Head	1
5	14850	68505	Cooling Sleeve	1
6	14984	68506	Handle	1
7	14848	68507	Central Body	1
8	14849	68508	Clamp & Screw	1
9	14996	68509	Extruder Screw	1
10	14840	68510	Square Joint	1
11	14897	68511	Tang	1
12		68512	Bosch Drill	1
13	14950	68514	Heat Element 110V	1
14	14951	68513	Heat Element 220V	1
15	14999	68515	Thermostat	1
16	14873	68516	Control Box	1
17	14959	68517	Screw Control Box	1
18	14958	68518	Screw/Thermostat	1
19	14980	68519	Knob	1
20	14964	68520G	Green Pilot Light	1
20	14963	68520R	Red Pilot Light	1

Picture No.	Order No.	Mfr. No.	Description	Qty. Req.
22	14841	68522	Muffler	1
24	15004	68524	Retractable Reel	1
25		68525	Cord Fitting	1
27		68527	Terminal Block	1
29		68529	Front Bushing	1
30		68530	Back Bushing	1
N/A		68538	Clamp Screw	1
21	14989	685CA	Cord Assembly	1
N/A	14943		Retro-Fit Kit Converts Bosch to Ingersoll-Rand Air Motor	1

WINNER AS Spotter

- See page 87 for product details

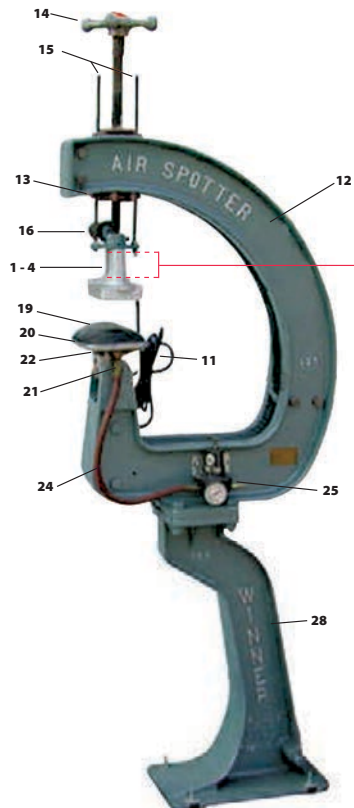

Note: Measure this distance
Either 2" or 4.5" to order
correct Part Number.
See numbers listed below.

Myers Part No.

36613 ASA115 Heater Assembly 2" - 115V
ASA230 Heater Assembly 2" - 230V

36611 ASA115/4.5 Heater Assembly 4-1/2" 115V
ASA230/4.5 Heater Assembly 4-1/2" 230V

Heater Assemblies & Heater Parts

Picture No.	Order No.	Mfr. No.	Description
1	36613	ASA115	Heater Assembly 2"-115V
2		ASA230	Heater Assembly 2"-230V
3	36611	ASA115 /4.5	Heater Assembly 4.5"-115V**
4		ASA230 /4.5	Heater Assembly 4.5"-230V**
N/A		AS13	Upper Housing Casting 2"
N/A		AS13/3.5	Upper Housing Casting 3.5"***
N/A		AS14	Lower Housing Casting
N/A	36612	ASB115	Element (Mica) 115V
N/A		ASB230	Element (Mica) 230V
N/A	36487	B200	Thermostat - 115 /230 V
11		CORD	Electrical Cord for Heater Assembly
12		ASX	Main "C" Frame
13		AS2	Swing Head Nut
14		AS4	Swing Head Pressure Screw
15		AS5	Swing Head Guide Rods (2-Req)
16		AS7	Heater Handle Assembly
N/A	36614	AS812	Heat Booster Pad 115V (5"x9"x1-1/2")
N/A		AS813	Transformer to Reduce 230V to 115V
19	36615	AS8	Air/Steam Bag (5"x9"x1-1/2")
20		AS18	Air Bag Backing Plate (Marked AS-4)
21		AS19	Brass Fitting Assembly
22		AS20	Backing Plate Hinge Pin
N/A		AS21	Backing Plate Locking Pin w/Chain
24		AS22	Air Line Hose Assembly
25		AS23	Air Regulator Assembly (Reg-Gauge-Bracket)
N/A		AS27	Quick Coupler 1/4"
28		AS29	Floor Stand - (AS-3)
N/A		AS31	Foot Pedal - (Marked AS-6)
N/A		AS33	Foot Pedal Double T-Rod - (2-Req.)
N/A		AS35	Foot Pedal T-Rod Bracket - (2-Req.)

Parts Breakdown

LINCOLN 1400 Spotter

- See page 44 for product details

Order No.	Mfr. No.	Description
36413	T039	Upper Heat Unit, Swivel (110 Volt)
36415	T039	Upper Heat Unit, Swivel (220 Volt)
31623	T051	"Silicone Rubber Heat Pad (4" Dia.) with Elec. Conn (110 Volt)
36417	T062	Silicone Rubber Seal (4" Dia.)
	T065	Steel Air Cylinder w/Contoured Lip
LINT071	T071	Air Hose from Regulator to Cylinder
LINT115	T115	Hand-Wheel and Pressure Screw
LINT119	T119	Air Regulator (Preset to 60 P.S.I.)
LINT120	T120	Air Gauge for Regulator
36264	T121	Detachable Electrical Cord for T051
	T174	Nut for Part#T115
	T175	Compression Spring
LINT176	T176	Fiber Rod
	T183	Frame (w/Gusset)
	T184	Telescoping Pressure Screw

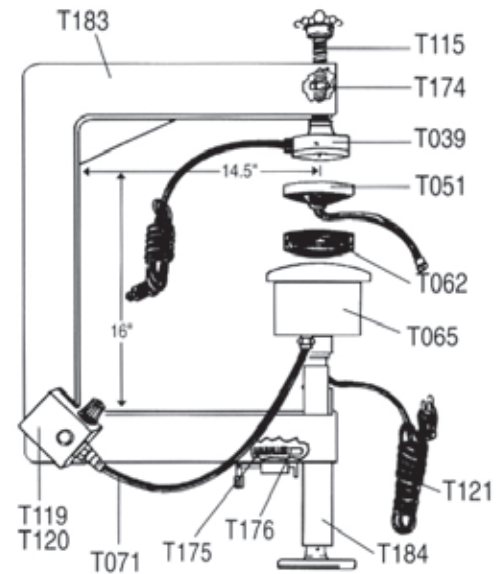

LINCOLN 2000 Spotter & Stand

Order No.	Mfr. No.	Description
31624	T057	Contoured Silicone Rubber Heat Pad (6" Dia.) w/Electrical Connection (110 Volt)
LINT057220	T057	Contoured Silicone Rubber Heat Pad (6" Dia.) w/Electrical Connection (220 Volt)
36263	T060	Solid Heat Units (110 Volt) (2 Req.)
LINT060220	T060	Solid Heat Units (220 Volt) (2 Req.)
36418	T063	6" Diameter Silicone Rubber Air Seal
LINT064	T064	Steel Air Cylinder w/Contoured Lip
36264	T121	Detachable Electrical Cord for T057
LINT192	T192	Detent pin
	T227	Plunger
LINT228	T228	Spring
	T229	Extension Shaft
	T239	Frame
	T240	Telescoping Assembly
	T277	Air Hose (with two fittings)
	T242	Stand Base Plate with Vertical Post
	T243	Roller Support Assembly (less rollers)
	T244	Rollers (2) 16" Long (2 Req.)
	T245	Front Legs (2 Req.)
	T246	Rear Leg with Tabs
	T247	Lower Vulcanizer Swivel Arm (with 1 nut & washer set)
	T248	Upper Vulcanizer Swivel Arm (with 1 nut & washer set)
	T249	Telescoping Vulcanizer Mounting Post
	T250	Vulcanizer Height-Adjusting Screw with Handle
	T251	Vulcanizer Mounting Bushings (2 Req.)
	T252	Locking Nut
	T253	Complete Assembly bolt & nut package (not shown)

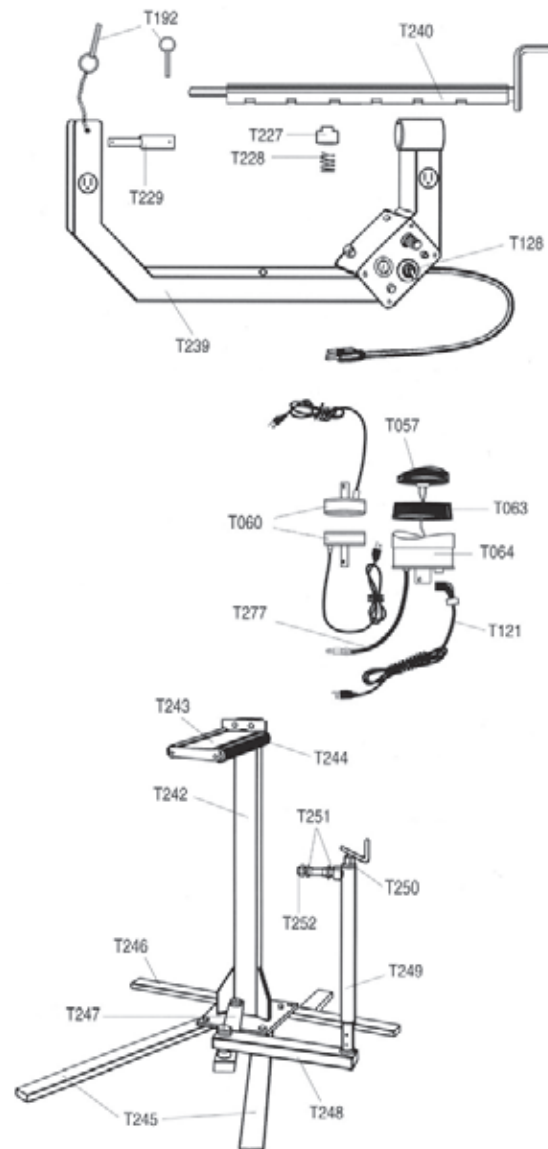

HAWKINSON Medium Truck Probe Assembly

• See page 52 for product details

For a complete list of parts, contact your local Myers Sales Professional.

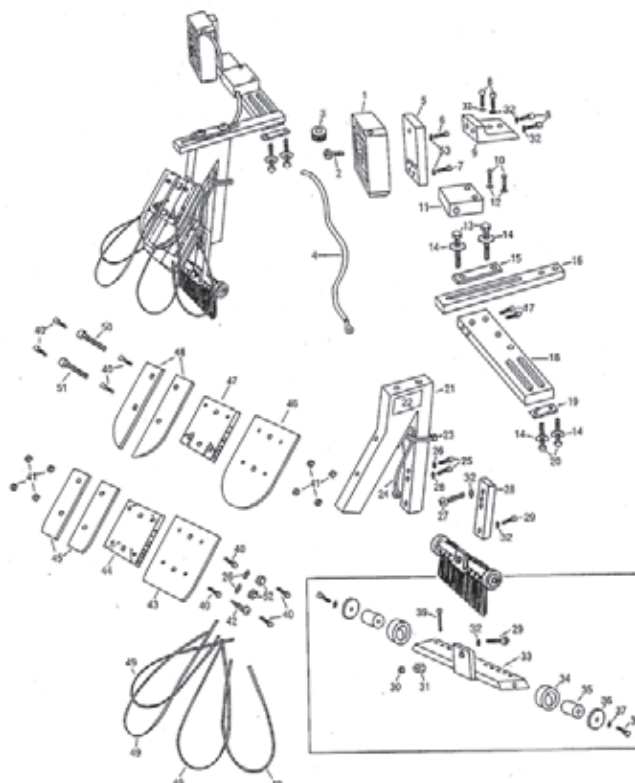

Picture No.	Order No.	Mfr. No.	Description
1	57600	H02-0024	HV SLAVE SQ.
2	57601	H50-0122	3/16 x 3/4 BHEAD
3	57602	H52-0024	3/16 WASHER
4	57647	H02-0058	PROBE WIRE
5	57603	H75-0004	HV SLAVE BACK
6	57604	H50-0086	10-32 x 3/4 BHEAD
7	57605	H50-0088	10-32 x 3/4 BHEAD
8	57606	H50-0071	1/4 x 3/4-28 SOCK
9	57607	H70-0080	ANGLE SUPPORT
10	57608	H50-0075	10-24 x 1 PHILH
11	57609	H11-0008	HVWIRESTANDOFF
12	57610	H51-0030	#10 INT LOCK WA
13	57611	H50-0100	3/8 x 1-1/2 BHEAD
14	57612	H52-0016	3/8 EXT LOCK WA
15	57613	H75-0002	3/8-DBL-WA-SGL
16	57614	H70-0083	BAR-SLOTTED-SGL
17	57615	H50-0037	1/4-28 x 2 SOCK
18	57616	H70-0081	BAR-SLOTTED-DBL
19	57617	H75-0001	3/8-DBL-WA-DBL
20	57618	H50-0104	3/8 x 1-3/4 BHEAD
21	57619	H11-0019	NDTII-K-HEAD
22	None	H80-0001	NDT - PROBE DECAL
23	57620	H53-0009	TSOROM4 TY-WRAP
24	57621	H02-0075	JUMPER WIRE #1
25	57622	H50-0045	1/4 x 1-1/2 SOCK
27	57623	H50-0056	1/4 x 1/2 PHILH
28	57624	H75-0011	K-HEAD BAR
29	57625	H50-0069	1/4X3/4 SHOLD
30	57626	H59-0010	10-24 HEX NUT
31	57627	H51-0010	10-24 FLEX L/N

Picture No.	Order No.	Mfr. No.	Description
32	57628	H51-0036	1/4 INT LOCK WA
33	57629	H03-0034	MED. TRK. CHAIN
34	57630	H20-0029	GEN-99R10 BEARING
35	57631	H20-0009	226935 1 BUSHING
36	57632	H51-0009	1/4 X 1 FENDER
37	57633	H52-0009	1/4 SPLIT LOCK
38	57634	H50-0040	1/4X1 BHEAD
39	54449	H40-0021	NDT-CHAIN
40	57635	H50-0085	10-32 CAP SCREW
41	57636	H51-0014	10-32 KEP NUT
42	57637	H50-0001	#10X3/4 SCREW
43	57638	H11-0026	INSP-PADDLE-MOD

Picture No.	Order No.	Mfr. No.	Description
44	57639	H75-0013	LOWER PADDLE
45	57640	H11-0009	INSP-1/2-PAD M
46	57641	H11-0010	INSP-PADDLE
47	57642	H75-0016	UPPER PADDLE
48	57643	H11-0027	INSP-1/2-PADDLE
49	54448	H42-0007	BT0B-19-WIRE
49-A	54444	None	H.D. Inserted BT0B-19-Wire
50	57644	H50-0051	1/4X1-3/4 HEX
51	57645	H50-0060	1/4X2 HEX HEAD BOLT
52	57646	H51-0029	1/4-20 HEX NUT

HAWKINSON NDTII Inspection Spreader

• See page 52 for product details

For a complete list of parts, contact your local Myers Sales Professional.

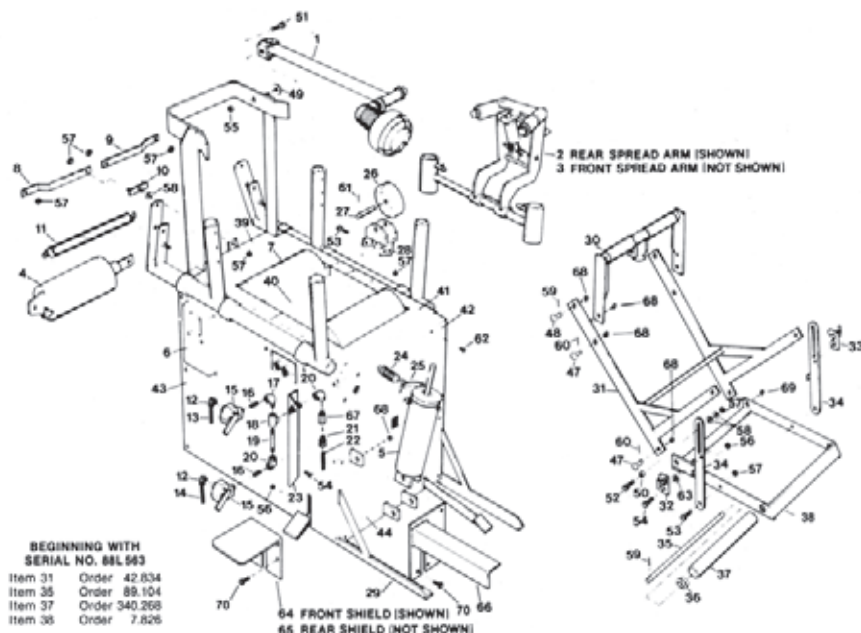

Picture No.	Order No.	Description	Qty. Req.
71	54455	Spread Rollers (Set of 4)	1
72	54456	Bead Rollers (Set of 2)	1

Parts Breakdown

LINCOLN Vulcanizer Plates

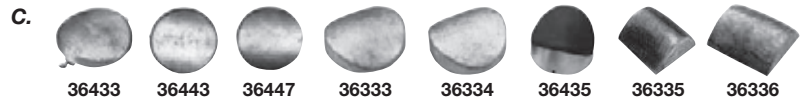
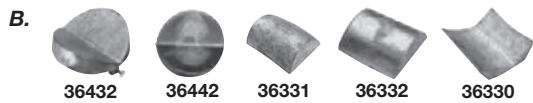

Vulcanizer Application

Vulcanizer	300	400	1000	1400	2000	LT	MT			
Plate Package	36273	36274	36276	36278	36280	36277	36279			
Order No	Ref. No.	Mfg. No.	Description	T149	T150	T152	T154	T156	T153	T155
A. Tread Area Truck Contour Plates										
36434	49	T080	4" Outside Tread Curing Plate	1	1	1	1		1	
36445	58A	T082	5" Inside Flat Radius Curing Plate		1	1	1			
36444	59	T085	5" Outside Tread Curing Plate		1	1				
36329	TPI	T130	Inside Tread Plate for All Tires					1		1
36328	TPO	T131	Outside Tread Plate for All Tires					1		1
B. Shoulder Area Truck Contour Plates										
36432	45	T078	4" Outside Shoulder Curing Plate	1	1	1	1		1	
36442	55	T081	5" Outside Shoulder Curing Plate		1	1	1			
36331	25SSH	T132	Inside Shoulder Plate for 255 Low Profile					1		
36332	28SSH	T133	Inside Shoulder Plate for 285 Low Profile					1		
36330	SHO	T134	Outside Shoulder Plate for All Tires					1		1
C. Sidewall Area Truck Contour Plates										
36433	48	T079	4" Inside Contour Curing Plate	1	1	1	1		1	
36443	58	T083	5" Inside Medium Radius Curing Plate		1	1	1			
36447	58S	T084	5" Inside Sharp Radius Curing Plate		1	1	1			
36333	68	T086	6" Inside Sidewall/Shoulder Plate For 11R					1		1
36334	68S	T087	6" Inside Sidewall/Shoulder Plate For Bias					1		1
36435	AS3-CP	T093	4" Cushioned Inside Plate						1	
36335	255SW	T135	Inside Sidewall Plate for 255 Low Profile					1		
36336	285SW	T136	Inside Sidewall Plate for 285 Low Profile					1		
D. Tractor Contour Plates										
36319	L1	T088	4" x 5 1/4" Left Outside Tractor Plate			1	1			
36320	L2	T089	4" x 5 1/4" Left Inside Tractor Plate			1				
36321	R1	T090	4" x 5 1/4" Right Outside Tractor Plate			1	1			
36322	R2	T091	4" x 5 1/4" Right Inside Tractor Plate			1				
E. Contour Bags										
36296	P1	T094	4 1/2" x 6 1/8" Flat Adapter Plate for B2 Bag			2	1			
36298	B2	T095	4" x 6" Pliable Contour Bag (Short Strap)			2	1			
36323	B3	T096	4" x 6" Pliable Contour Bag (Long Strap) for GT2B Spotter Only							